

CATÁLOGO TÉCNICO DE PRODUTOS

REVISÃO 02



Dispan



Uma História de Sucesso

A History of Success

Desde 1985 no mercado, nossa especialidade é desenvolver e fabricar infraestruturas metálicas como eletrocalhas, perfilados, aramados e leitos tipo escada para passagem de cabos. Para cada linha de produto, oferecemos um conjunto completo de conexões e materiais de fixação.

Com sede na cidade de Nova Odessa, uma filial em São Paulo e vários representantes por todo território nacional, somos um dos maiores fornecedores do setor no Brasil.

Contamos com mais de 10.000 m² de parque fabril, equipado com as mais modernas tecnologias, para atender todos os requisitos de qualidade do mercado. Nossos produtos são fabricados com matéria-prima adquirida nas principais usinas nacionais, que oferecem certificados de qualidade, garantindo alta resistência e comprovada qualidade do material.

With more than 25 years working, our specialty is develop and manufacture infrastructure for passing cables like cable trays, steel profiles, wire fitting and bed ladders. For each product line, we offer a complete set of connections and fixation materials.

With the headquarters in Nova Odessa, a branch in São Paulo and several representatives throughout the country, we are one of the largest supplier of this industry in Brazil.

We have more than ten thousand square meters of industrial park, equipped with the latest technologies for meeting all quality requirements of the market. The raw material of our products is gained at the main national mills, which offer quality certificates, ensuring the high strength and the quality of the material.



Responsabilidade Empresarial

Business Responsibility

Seguimos uma política de melhoria contínua, por meio da padronização de todos os nossos processos, estabelecendo normas, globalizando procedimentos e agregando valores aos nossos produtos. Focamos na satisfação de nossos clientes, através da instituição de um paralelo entre preço, qualidade e prazo.

Lançando mão de artefatos e ferramentas que auxiliam nossos clientes durante o desenvolvimento de projetos e gerando benefícios mútuos na relação cliente-fornecedor, nós fazemos a diferença. Experiência e dedicação formam um departamento comercial diferenciado, com atendimento personalizado, que permite conhecer todas as exigências de nossos clientes e supri-las com eficiência e segurança. Possuímos um departamento técnico com engenheiros e projetistas especializados, que atuam no desenvolvimento de novos produtos e oferecem todo suporte necessário, para garantir a utilização correta do produto e evitar riscos durante o processo de instalação. Nossa principal conduta é industrializar produtos de alto padrão, que vão de encontro às necessidades de nossos clientes.

We follow a policy of continuous improvement through standardization of all our processes, establishing norms, globalizing processes and adding value to our products. We focus on the satisfaction of our customers by establishing a line between price, quality and deadline.

Using artifacts and tools that help our customers during the development of projects and creating mutual benefits in the customer-supplier relationship, we make the difference. Experience and dedication make a differentiated commercial department, with personalized care, that allows us knowing all the demands of our customers and supply them with efficiency and safety. We have a technical department with expert engineers and designers working on developing new products, and providing all necessary support to assure the correct use of the product, so they can avoid risks during the installation process.

Our main management is industrialize high standard products, which meet the needs of our customers.

Áreas de Atuação

Practice Areas

Petróleo e Gás • Siderúrgica • Alimentícia
Açúcar e Álcool • Papel e Celulose • Mineração
Farmacêutica • Comercial • Offshore

Oil and Gas • Steelmaker • Food Industry
Sugar and Alcohol • Paper and Pulp • Mining
Pharmaceutics • Commercial • Offshore



Plugins

Plugins

Além de ser referência na fabricação e distribuição de eletrocalhas, perfilados, leitos e aramados, a Dispan oferece o DPCAD: Um plugin que consiste numa ampla biblioteca 3D desses produtos, facilitando a concepção da área elétrica em seus projetos. Acesse o site da Dispan, assista as videoaulas e faça o download do programa, gratuitamente: www.dispan.com.br

Besides being a reference in manufacturing and distributing cable trays, steel profiles, wire fitting and bed ladders, Dispan offers the DPCAD: a plug-in that consists on a large library of these products in 3D, making it easier to conception of the electric field in their projects. Visit the Dispan website, watch the video classes and download the program free: www.dispan.com.br

DPCAD

Patenteado



Qualidade Reconhecida

Recognized Quality



Prêmio Qualidade
Quality Award



Certificação
ISO 9001 : 2015
ISO 9001 : 2015 Certification

Catálogo
Navepeças

Catálogo Navepeças
Navepeças Catalog



Certificado ONIP
ONIP Certificate

Política de Qualidade

QUALITY POLICY

A Dispan tem como política de qualidade produzir e comercializar eletrocalhas, perfilados, leitos para cabos, eletrocalhas aramadas, acessórios e conexões para toda linha. Buscando sempre atender com eficácia os requisitos das partes interessadas, visando a melhoria contínua dos processos, lucratividade e satisfação dos clientes.

Desde outubro de 2010, a DISPAN está certificada de acordo com a Norma ISO 9001:2008, tendo sido atualizado a partir de abril de 2019 com a nova versão ABNT NBR ISO 9001:2015. Para nós, significa que o nosso Sistema de Qualidade segue os passos que garantem a satisfação do cliente através da melhoria contínua e do envolvimento e qualificação dos nossos colaboradores. Para os nossos clientes, significa o reforço da confiabilidade com que servimos as normas e que nos preocupamos com o desenvolvimento e exigências do mercado.

DISPAN aims the manufacturing and marketing of cable trays, steel profiles, beds for cables and a full line of accessories, with fast delivery and care about product requirements, seeking customer satisfaction through continuous improvement of quality management system with the involvement and training of our employees.

Since October 2010, DISPAN is certified in accordance with the Standard ISO 9001:2008. For us, it means that our Quality System follows the steps that ensure customer satisfaction through continuous improvement and involvement and qualification of our employees. For our customers, it means strengthening of reliability which we serve the standards and that we care about the development and market requirements.

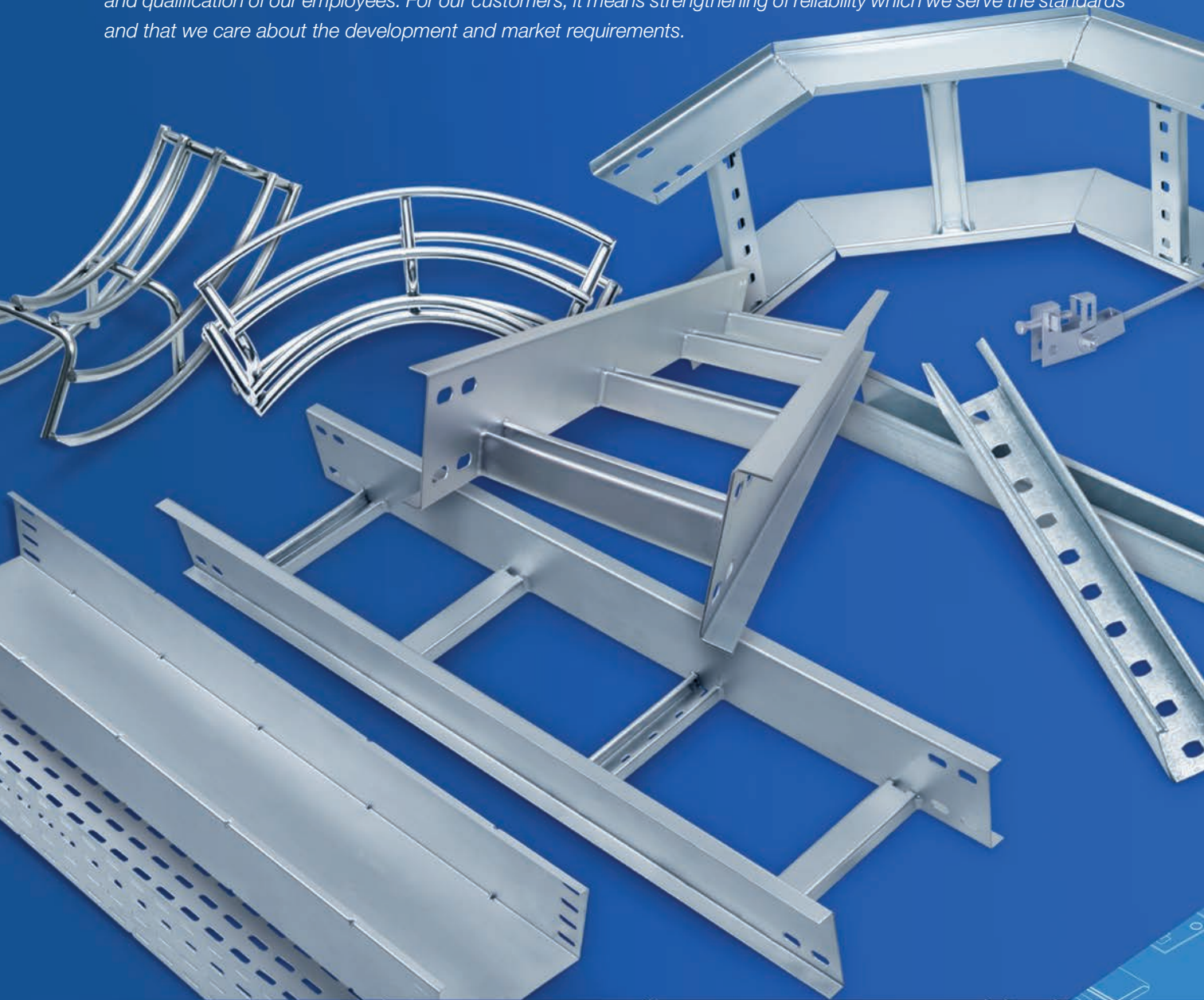

Matérias-primas básicas para produção

Basic raw materials for production

A Dispan trabalha com diversos tipos de materiais para o melhor atendimento das necessidades dos nossos clientes e parceiros. Dentre os materiais mais solicitados, estão:

Dispan works with several types of materials to improve our services to customers and partners. Among the most requested materials, there are:

AÇO CARBONO – 1008 E 1010 (AC) **CARBON STEEL – 1008 AND 1010 (AC)**

O aço carbono 1008 e 1010 são os materiais mais utilizados, pois os mesmos podem receber diversos tipos de acabamentos para melhoria da estética, bem como maior resistência às intempéries, tais como acabamento por galvanização a fogo à base de zinco por imersão (GF), galvanização contínua à base de zinco, ou pré-zincagem (PZ), galvanização contínua à base de 50% de zinco e 50% de alumínio (galvalume), galvanização eletrolítica à base de zinco por eletrólise e pintura epóxi ou eletrostática a pó.

The carbon steel 1008 and 1010 are the most used materials because they can receive several types of finishes, for the improvement of esthetics as well as the improvement of resistance to weathering, such as hot-dip galvanizing with zinc, pre-galvanizing, galvanizing with 50% zinc and 50% aluminum, electrolytic galvanizing with zinc by electrolysis and epox painting or electrostatic powder.

AÇO INOX– 304, 316, 316L E 316I (AI) **STAINLESS STEEL – 304, 316, 316L AND 316I (AI)**

Material muito utilizado em segmentos nos quais a limpeza seja contínua ou a agressividade do ambiente seja elevada.

Por se tratar de um material mais nobre, o aço inox tem sido muito utilizado em indústrias alimentícias, estações de tratamento de águas e esgoto, refinarias de combustíveis e em alguns setores mais agressivos, como em usinas sucroalcooleiras e papelarias.

This material is widely used in sections where the cleaning is continuous, or the aggressiveness of the environment is high. Because it is a nobler material, stainless steel has been often used in food industries, in water treatment and sewage plants, in fuel refineries, in some sectors more aggressive in sugarcane mills and paper mills.

ALUMÍNIO (AL) **ALUMINUM (AL)**

O alumínio também é um material nobre e, com a vantagem de um ótimo acabamento, pode criar estruturas extremamente rígidas com um peso bem menor em relação aos outros materiais ferrosos. Este material tem sido muito utilizado em áreas onde o peso elevado pode trazer problemas de sobrecarga em suas estruturas.

Aluminum is also a noble material and with the advantage of have an excellent and it can create extremely rigid structures with a lower weight compared to other ferrous materials. This material has been widely used in areas where weight can bring overload problems in the structure.

Acabamento para o Aço Carbono

Finishing for Carbon Steel

Existem diversos tipos de acabamentos para fins estéticos ou de proteção do aço carbono 1008/1010. Em nosso ramo de atividade, os acabamentos mais utilizados são:

- GALVANIZADO A FOGO (GF) • PRÉ-ZINCADO (PZ)
- GALVANIZADO ELETROLÍTICO (GE) • PINTURA ELETROSTÁTICA (PT)

There are several types of finishes for aesthetic purposes or protection of carbon steel 1008/1010. In our field of activity, the most used finishes are:

- Hot dip galvanized (GF) • Pre-zincated (PZ)
- Electrolytic galvanized (GE) • Electrostatic painting (PT)

GALVANIZADO A FOGO (GF) NBR-6323

HOT DIP GALVANIZED (GF) NBR-6323

A galvanização a fogo é um processo de aplicação de um revestimento de zinco em estruturas de aço ou ferro fundido, através da imersão destes materiais em um banho de zinco fundido. A simplicidade do processo e os baixos custos ao longo do tempo trazem à galvanização a fogo por imersão uma vantagem sobre os outros métodos de proteção contra corrosão.

O processo de galvanização a fogo compreende a imersão das estruturas metálicas em um banho de zinco fundido a uma temperatura de aproximadamente 450 °C, isso somente após uma adequada limpeza e preparação das peças a serem protegidas pelo banho de zinco. O rápido ataque da superfície da estrutura pelo zinco fundido produz uma camada composta por diferentes ligas zinco/ferro, que desenvolvem uma ligação muito forte com a superfície. Esta união é chamada de "interação metalúrgica". Após a remoção da estrutura do banho, uma camada de zinco puro passa a recobrir a superfície da peça, produzindo uma coloração brilhante, acinzentada ou prateada, bastante característica do processo de galvanização a fogo por imersão.

A camada Zn-Fe possui uma dureza semelhante a do aço, fornecendo uma barreira protetora (proteção catódica), protegendo a estrutura da corrosão. Em adição, as camadas formadas pelo zinco protegem a estrutura de abrasão e impactos acidentais durante o período de uso.

A galvanização a fogo por imersão tem seu processo perfeitamente definido, sendo basicamente o mesmo para qualquer produto, podendo variar na espessura da camada de zinco depositada dependendo da geometria da peça, composição química e espessura do material-base, no caso do aço carbono 1008/1010.

Neste processo de galvanização a fogo por imersão, as peças recebem uma camada de aproximadamente 49 a 60 microns de zinco, conforme a NBR-6323.

INDICAÇÃO DE USO - Este tipo de acabamento e proteção é mais indicado para:

- uso externo com situação de intempérie;
- locais com produtos químicos leves;
- indústrias pesadas, como mineradoras, papel e celulose, óleo e gás, sucroalcooleiras, fundições etc.;
- em áreas costeiras, com salinidade moderada.

Hot dip galvanized is a process for applying a zinc coating on steel structures or cast iron, through the immersion of these materials in a bath of molten zinc. The simplicity of this process and the lower costs over time are advantages over other methods of protection against corrosion. This process comprises immersing the metal structures in a bath of molten zinc at a temperature of approximately 450°C, but only after proper cleaning and preparation of the parts to be protected by the zinc bath. The fast attack of the structure surface by the molten zinc produces a layer composed of different zinc/iron alloy which develops a very strong bond with the surface. This union is called metallurgical interaction. After removing the structure from the bath of molten zinc, a layer of pure zinc becomes cover the surface of the piece, producing a shiny grayish or silvery quite characteristic of the process of hot dip galvanized by immersion.

The Zn-Fe layer has a hardness similar to steel, providing a protective barrier (cathodic protection), protecting the structure from corrosion.

In addition, the zinc layers protect the structure from abrasion and accidental impacts during the use.

Hot dip galvanized by immersion has its process clearly defined, being almost the same for any product. This can vary in thickness of the zinc layer deposited depending on geometry of the piece, chemical composition and thickness of the base material, in this case, the carbon steel 1008/1010.

In this process of hot dip galvanized by immersion, the pieces receive a layer of approximately 49 microns of zinc, according to NBR-6323.

INDICATION OF USE - This type of finishing and protection is best suited for the conditions listed below:

- Outdoor use with weatherproof situation.
- Places with mild chemicals.
- Heavy industries, such as mining, paper and cellulose, oil and gas, sugarcane, foundries, etc.
- In coastal areas with moderate salinity

Acabamento para o Aço Carbono

Finishing for Carbon Steel

PRÉ-ZINCADO (PZ) - NBR-7008/7013

PRE-ZINCED (PZ) – NBR 7008/7013

Hoje, o processo de revestimento contínuo por imersão a quente para chapas de aço é amplamente utilizado e empregado em todo o mundo, originalmente desenvolvido há mais de cinquenta anos para galvanização com revestimentos de zinco.

Este processo se tornou uma operação avançada tecnicamente e muito sofisticada, sendo possível graças à disponibilidade de sistemas de controles computadorizados mecânicos/elétricos. O revestimento contínuo por imersão a quente, mais conhecido como “pré-zincagem”, tem como princípio básico a aplicação de um revestimento fundido à base de zinco na superfície de uma chapa de aço, por um processo contínuo, ou seja, a chapa de aço é passada continuamente por um banho de metal fundido (neste caso, o zinco) a uma velocidade de 600 pés por minuto. No banho de zinco fundido, a chapa de aço reage com o metal fundido, transformando-a em uma superfície mais resistente e com melhor acabamento.

Neste processo de imersão contínua, as chapas de aço recebem uma camada de aproximadamente 06 a 18 microns de zinco.

INDICAÇÃO DE USO - Este tipo de acabamento e proteção é mais indicado para:

- uso interno com baixa umidade, de pr ros);
- áreas cobertas, do tipo shopping centers, centros de distribuições, supermercados; atacadistas, hospitais etc.

Nowadays, the continuous process of hot dip coating for sheet steel or pre-zincated are widely used around the world. The development of this process occurred originally more than 50 years ago for galvanization with zinc coatings. This process became a technically advanced operation and very sophisticated. It became possible because of the availability of mechanical/electrical computerized controls systems. The basic principle, as its name implies, involves applying a molten coating zinc based on the surface of a steel sheet by a continuous process. The sheet steel is continuously passed through a bath of molten metal, in this case zinc, at a speed of 600 feet per minute. In the molten zinc bath, the steel sheet reacts with the molten metal to connect the coating to the steel strip or sheet, turning it into a stronger surface and with better finish.

In this continuous immersion process, the steel sheets receive a layer of approximately 15 to 30 microns of zinc.

INDICATION OF USE - This type of finishing and protection is best suited for the conditions listed below:

- Internal use with low humidity, preferably in dr
- Covered areas, like malls, distribution centers, grocery stores, wholesalers, hospitals, etc.

Acabamento para o Aço Carbono

Finishing for Carbon Steel

GALVANIZADO ELETROLÍTICO (GE) NBR-10476

ELECTROLYTIC GALVANIZED (GE) NBR 10476

Galvanização eletrolítica é um processo de eletrodeposição, denominado galvanoplastia. Trata-se de um processo de revestimento de materiais condutores ou não-condutores, por metais a partir de uma solução contendo íons destes metais.

Basicamente, o processo de galvanoplastia envolve uma sequência de banhos consistindo em etapas de pré-tratamento de revestimento e de conversão de superfície. Entre estas etapas as peças sofrem um processo de lavagem.

O processo eletrolítico consiste em revestir superfícies de peças de aço com outros metais mais nobres, neste caso o zinco. Este processo tem como objetivo proteger uma peça metálica da corrosão, bem como conferir melhor acabamento estético ou decorativo à mesma. Podemos definir galvanoplastia como a tecnologia responsável pela transferência de íons metálicos de uma dada superfície sólida ou meio líquido denominado eletrólito para outra superfície, seja ela metálica ou não. Este processo usa a corrente elétrica, sendo chamado de eletrólise.

Neste processo de galvanoplastia ou galvanização eletrolítica, as chapas de aço recebem uma camada de aproximadamente 2,5 a 8 microns de zinco.

INDICAÇÃO DE USO - Este tipo de acabamento e proteção é mais indicado para:

- locais internos, sem presença de umidade;
- áreas cobertas, normalmente cobertas em nichos fechados por forro.

Electrolytic galvanized is an electrodeposition process, called galvanoplasty. It is a coating process of conductors or non-conductors materials, by metals from a solution with ions of these materials.

Essentially, galvanoplasty process involves a sequence of baths, consisting in steps of pre-treatment of the coating and of surface conversion. Between these steps, the pieces undergo a washing process.

The electrolytic process consists in coating steel surfaces with other nobler metals, in this case with zinc. This process aims to protect a metal piece from corrosion, as well as check the best aesthetic or decorative finish. We can define galvanoplasty as the responsible technology for metal ions transfer from one solid surface or of a liquid called electrolyte, to another surface, a metal one or not. This process uses the electric current, so it is called electrolysis.

In this galvanoplasty process or electrolytic galvanized, the steel plate receives a coat approximately 2.5 to 8 microns of zinc.

INDICATION OF USE - This type of finishing and protection is best suited for the conditions listed below:

- internal use with no humidity;
- covered areas, usually confined in niches closed by liner.



Acabamento para o Aço Carbono

Finishing for Carbon Steel

PINTURA ELETROSTÁTICA (PT)

ELECTROSTATIC PAINTING (PT)

A pintura eletrostática, ou lacagem, é um processo de pintura que tem como finalidade o revestimento da chapa de aço, alumínio ou outros metais com uma película de polímero termoendurecível colorido (pó de poliéster). Existem várias cores que podem ser utilizadas.

Este processo de pintura garante a flexibilidade da peça sem prejudicar a pintura. Quando a peça é pintada, a tinta recebe uma carga elétrica oposta à da peça, fazendo com que a tinta se fixe. Após este procedimento a peça é levada a uma estufa, na qual a tinta é aquecida para que se dê a cura da mesma e se fixe na peça desejada. Esta modalidade pode também ser usada para dar um melhor acabamento e apurar a estética do produto final ou reforçar a resistência contra a corrosão. Por diversas vezes, a pintura eletrostática já foi utilizada em acabamentos como galvanizados a fogo, galvalume, pré-zincados e eletrolíticos, bem como em materiais mais nobres como o aço inox e alumínio.

Neste processo de pintura eletrostática, as chapas de aço recebem uma camada de aproximadamente 50 à 60 microns de tinta.

INDICAÇÃO DE USO - Este tipo de acabamento e proteção é mais indicado para:

- locais internos, onde o acabamento estético tem prioridade;
- prédios de shoppings centers, grandes redes de supermercados, atacadistas, grandes lojas e locais onde este tipo de material fica totalmente aparente e exposto ao olhar do público.

The electrostatic painting or lacquering is a painting process that aims coat the steel or aluminum plate or other metal surface with a pellicle of colored thermosetting polymer (polyester powder). Many colors can be used.

This painting process ensures exibility to the piece without damaging part of the painting. When painting the piece, the ink receive an opposite electrical charge, making the ink stay on the piece. After this proceeding, the piece remains in a kiln, which warm the ink to make ink curing, so it stays on the surface of the wanted piece.

This modality can also be used to give a better ish and verify the aesthetics of the al product, or enhance corrosion resistance. On several occasions, the electrostatic painting has been used in finish like hot dip galvanized, Galvalume®, pre-zincs and electrolytic, as well as nobler materials like stainless steel and aluminum.

In this process of electrostatic painting, the steel plate receive a coat approximately 60 to 70 microns of ink.

INDICATION OF USE - This type of finishing and protection is best suited for the conditions listed below:

- Internal use, where the priority is aesthetic finish.
- Malls buildings, large grocery stores chains, wholesalers, large department stores, and locals where this type of material stay fully exposed and seeming to public.

*As informações sobre os produtos contidas neste catálogo podem sofrer alterações sem aviso prévio.
Consulte o departamento de engenharia da Dispan.*

Leitos

Cable trays ladder type



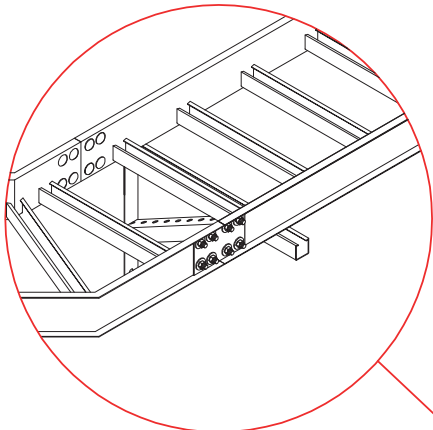

União feita por junção simples
DP849.

*Simple joiner connector
DP 849*

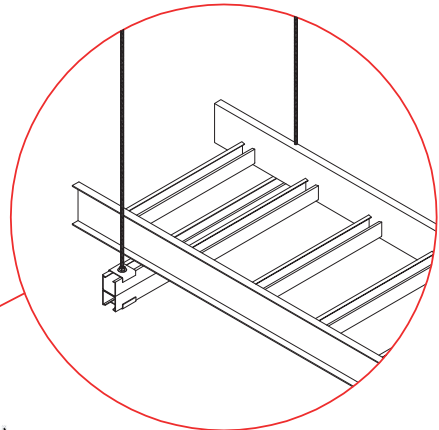

Suportação com perfilado
conjugado DP510.

*Support with welded
steel profile - DP 510*

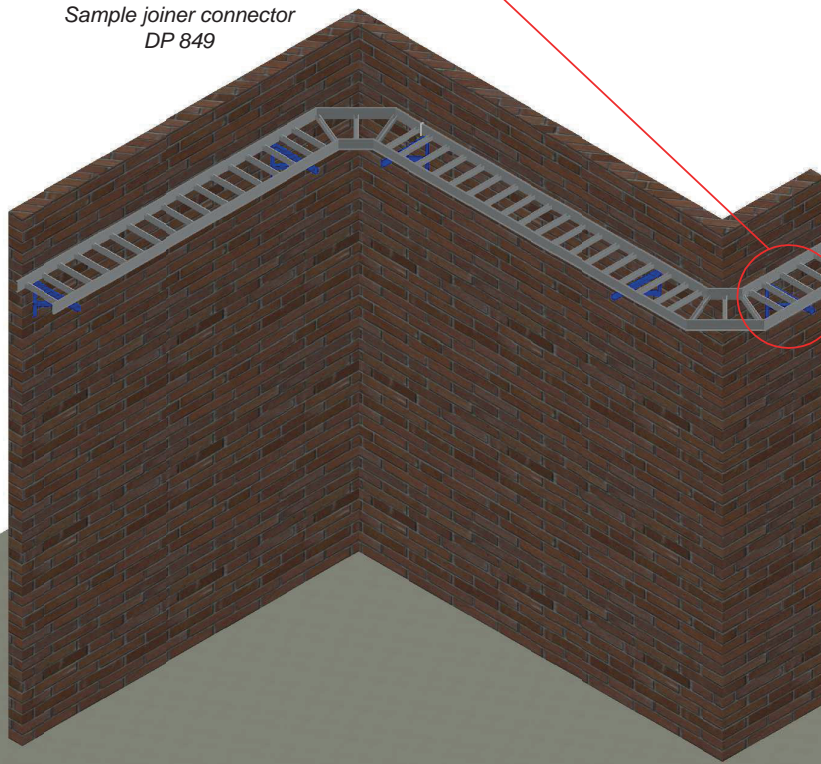

Suportação com mão francesa reforçada industrial DP748-i.

Support with industrial reinforced bracket - DP 748-I

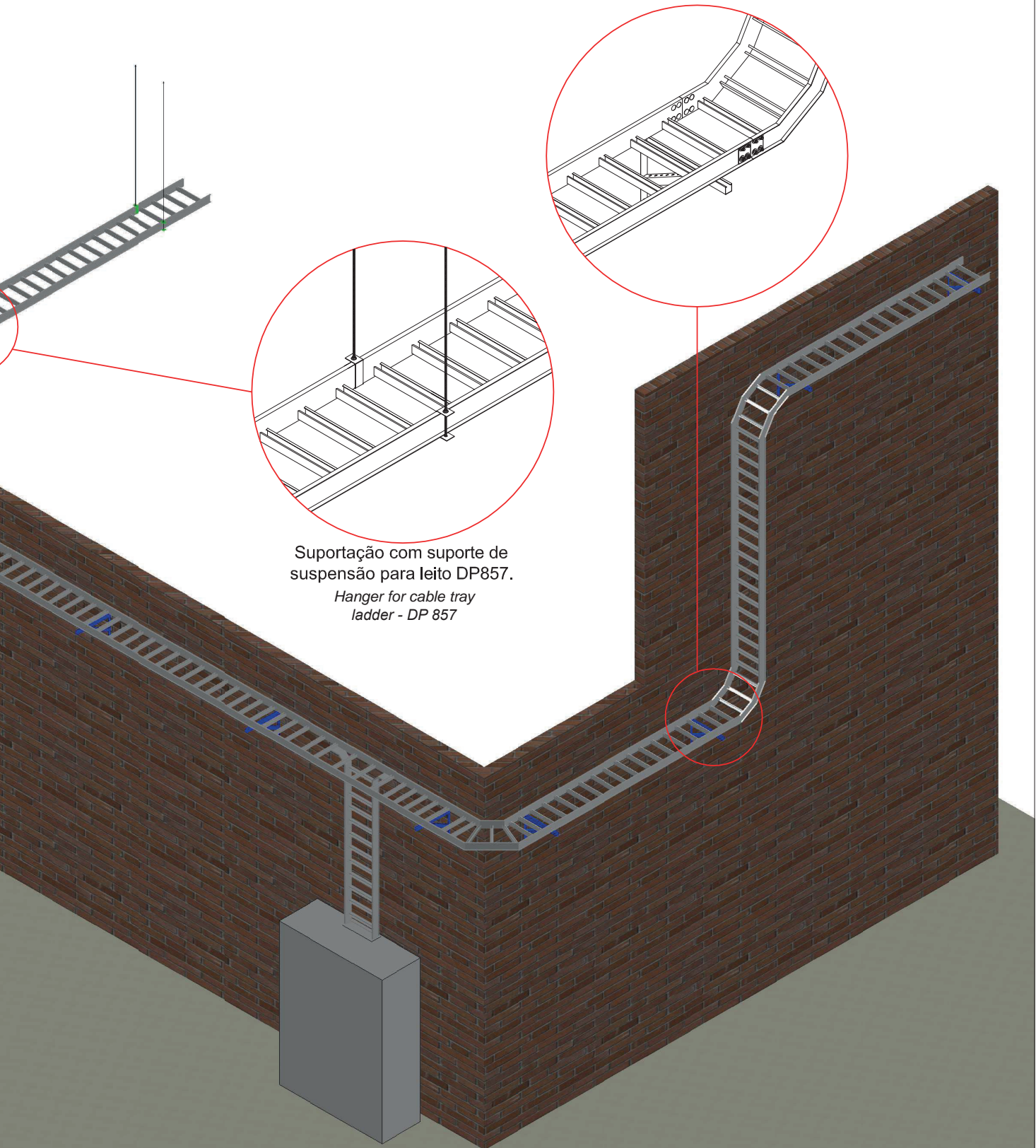

Suportação com suporte de suspensão para leito DP857.

Hanger for cable tray ladder - DP 857

Exemplo de como solicitar leitos

How to specify cable tray ladder type.

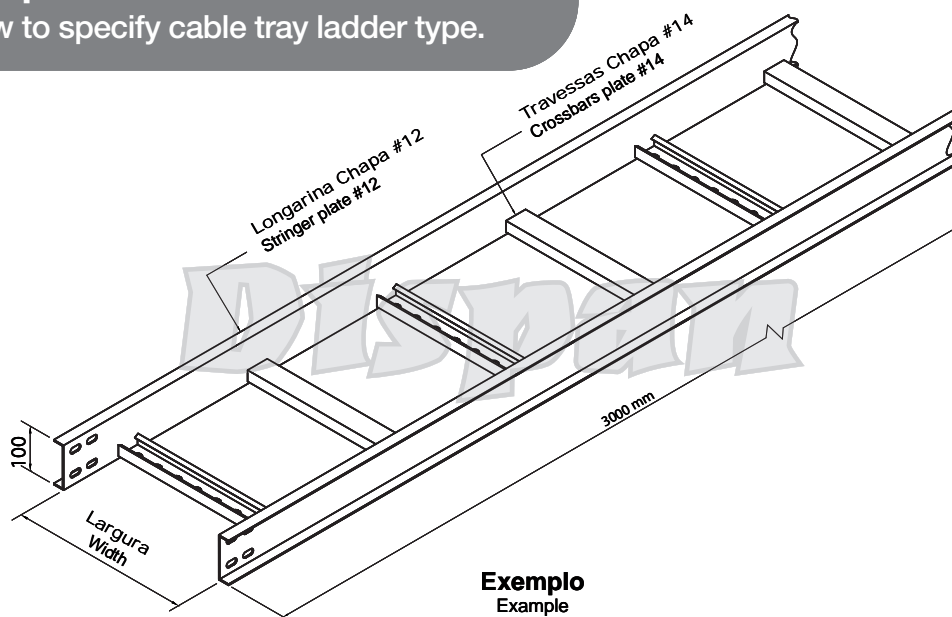

Exemplo
Example

DP 803-250 - AC - GF - AE - 400 - 12/14

Referência do catálogo de produtos com características básicas

Product catalog reference with basic features

Matéria-prima de fabricação

Manufacturing raw material

Acabamento

Finish

Posicionamento das abas

Positioning tabs

Chapas de construção do leito

Plate construction of the cable tray ladder

Largura do leito

Width of the cable tray ladder

DP 803 • Leito semipesado, longarina com 100 mm de altura e virola de 19 mm com travessas a cada 250 mm, em perfilado de 38 x 19 mm.

DP 803 • semi heavy cable tray ladder, stringer with 100 mm height and ferrule of 19 mm with crossbars in each 250 mm, profiled in 38 x 19 mm.

Matéria-prima base

Raw material base

AC - Aço carbono

Carbon Steel

AI - Aço inox

Stainless Steel

AL - Alumínio

Aluminum

Acabamento aplicado na matéria-prima em base de aço carbono

Finish applied to the raw material in carbon steel base

GF - Galvanizado à fogo por imersão

Hot dip galvanized

GE - Galvanizado eletrolítico

Electrolytic galvanized

PZ - Pré-zincado (cravado)

Pre-zincated (locked)

NT - Natural

Natural

PT - Pintado

Painting

Posição das abas

AE - com aba externa

External tabs

AI - com aba interna

Internal tabs

Largura: 400 - Largura do leito desejado (De 100 a 1500 mm).

Width: 400 – width of the wanted cable tray ladder (100 to 1500 mm).

Espessuras de chapas: 12 - Chapa das longarinas | 14 - Chapa das travessas

Plate thickness: 12 - stringers plate | 14 - crossbars plate

Descritivo técnico | Technical description

DP 803-250 • Leito semipesado com longarina de 100 mm de altura e virola de 19 mm, com travessas distanciadas a cada 250 mm, em perfilado de 38 x 19 mm em aço carbono galvanizado à fogo, aba externa, largura de 400 mm com longarinas em chapa #12 e travessas em chapa #14.

DP 803-250 • semi heavy cable tray ladder with 100 mm of height stringer and ferrule of 19 mm, with crossbars set 250 mm apart each, profiled in 28 x 19 mm of carbon steel hot dip galvanized, external tab, width of 400 mm with stringers plate #12 and crossbars plate #14.



ATENÇÃO!

A DISPAN INDÚSTRIA E COMÉRCIO não recomenda o uso de leito ou eletrocalha como passarela, escada ou apoio para pessoas.
USE APENAS PARA PASSAGEM DE CABOS.

UTILIZE OS EPI'S CONFORME NR-06 E SIGA AS PRÁTICAS DE SEGURANÇA NO TRABALHO, COMO DESCRITO NA NR-10 E NR-35.

Nota

Ocasionalmente podem ocorrer algumas distorções de medidas em nossas peças, por diversos fatores. Por este motivo damos uma tolerância de 5,0 mm entre as medidas mencionadas no catálogo e as peças reais. Os furos oblongos são feitos exatamente para compensação e ajuste de eventuais diferenças.

WARNING!

DISPAN Industry and Trade does not recommend using cable trays or bed ladder as walkway, stair or support for people.
USE ONLY FOR PASSING OF CABLES.

USE THE PPIS AS THE NR-06 AND FOLLOW THE WORK SAFETY PRACTICES AS DESCRIBED IN NR-10 AND NR-35.

Note

Occasionally, it may occur some distortion of measures in our pieces, for several reasons. Because of this, we give a toleration of 5.0 mm between the measures mentioned in this catalog and the real pieces. The slotted holes are made just for clearing and settling of any possible differences.



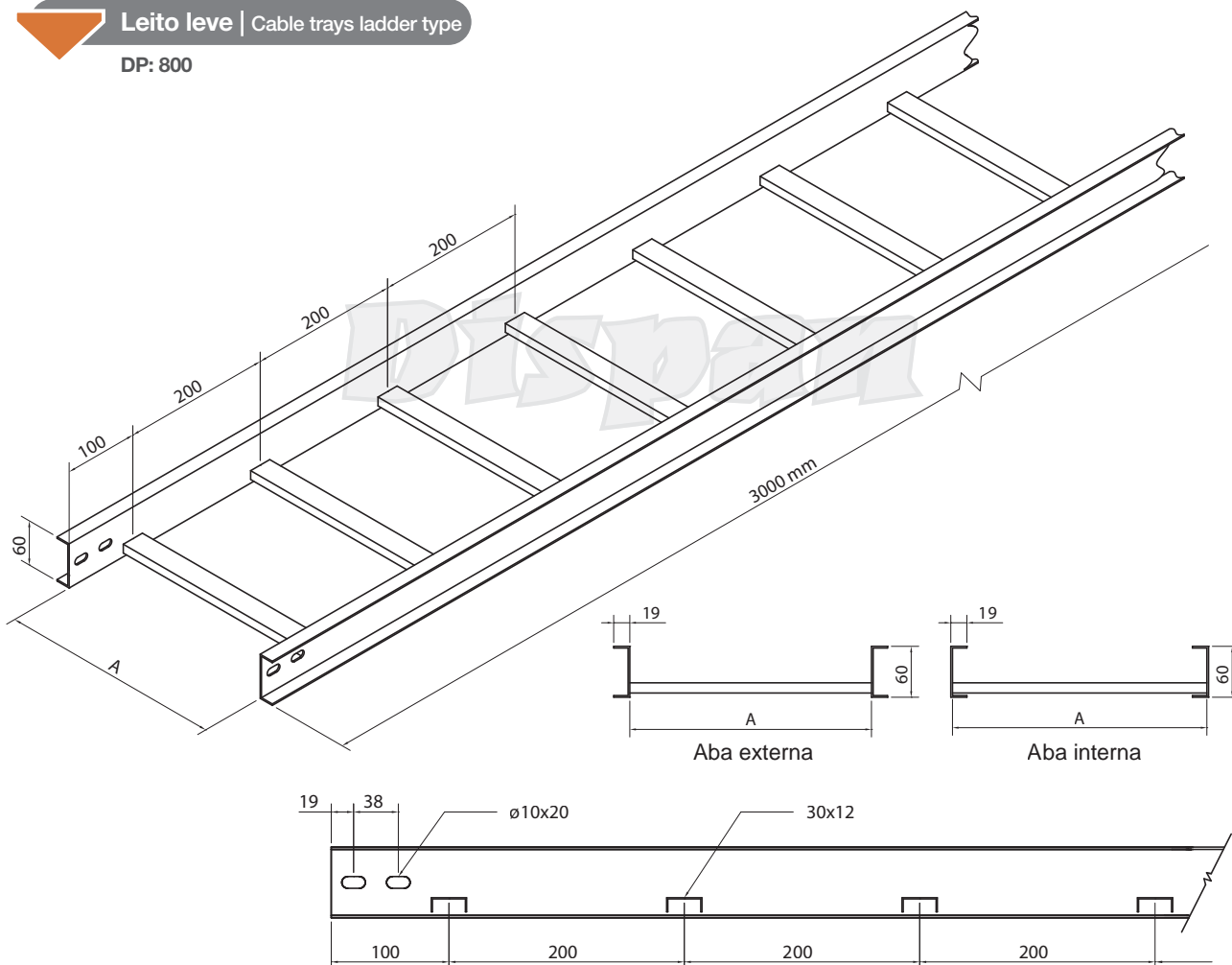

- * Obs.: Barra superior 3000 mm sob consulta.
- * Medidas não contidas em catálogo, favor consultar.

Carga uniformemente distribuída entre suportes, com material base em AC.
Uniformly distributed loads, between supports.

LARGURA mm Width	PESO POR BARRA Wight KG	Chapa Steel plate		Distância entre suporte Distance between supports / load KG				
		LONGARINA	TRAVESSAS	1000 mm	1500 mm	2000 mm	2500 mm	3000 mm
200	12,0	14	16	775	520	375	280	180
200	14,5	12	14	810	570	400	320	200
300	13,5	14	16	775	510	375	295	180
300	16,0	12	14	810	570	400	320	200
400	15,0	14	16	775	510	375	295	180
400	18,5	12	14	810	570	400	320	200
500	16,5	14	16	760	500	365	290	175
500	20,0	12	14	810	570	400	320	200
600	17,5	14	16	760	500	365	290	175
600	22,0	12	14	810	570	400	320	200
700	19,0	14	16	752	480	395	275	200
700	23,5	12	14	810	570	400	320	200
800	20,5	14	16	752	480	395	275	200
800	25,5	12	14	810	570	400	320	200
900	27,0	12	14	745	470	385	270	195
1000	29,0	12	14	745	470	385	270	195
1200	32,5	12	14	745	470	385	270	195

* Pesos estimados, somente para cálculos de carga.

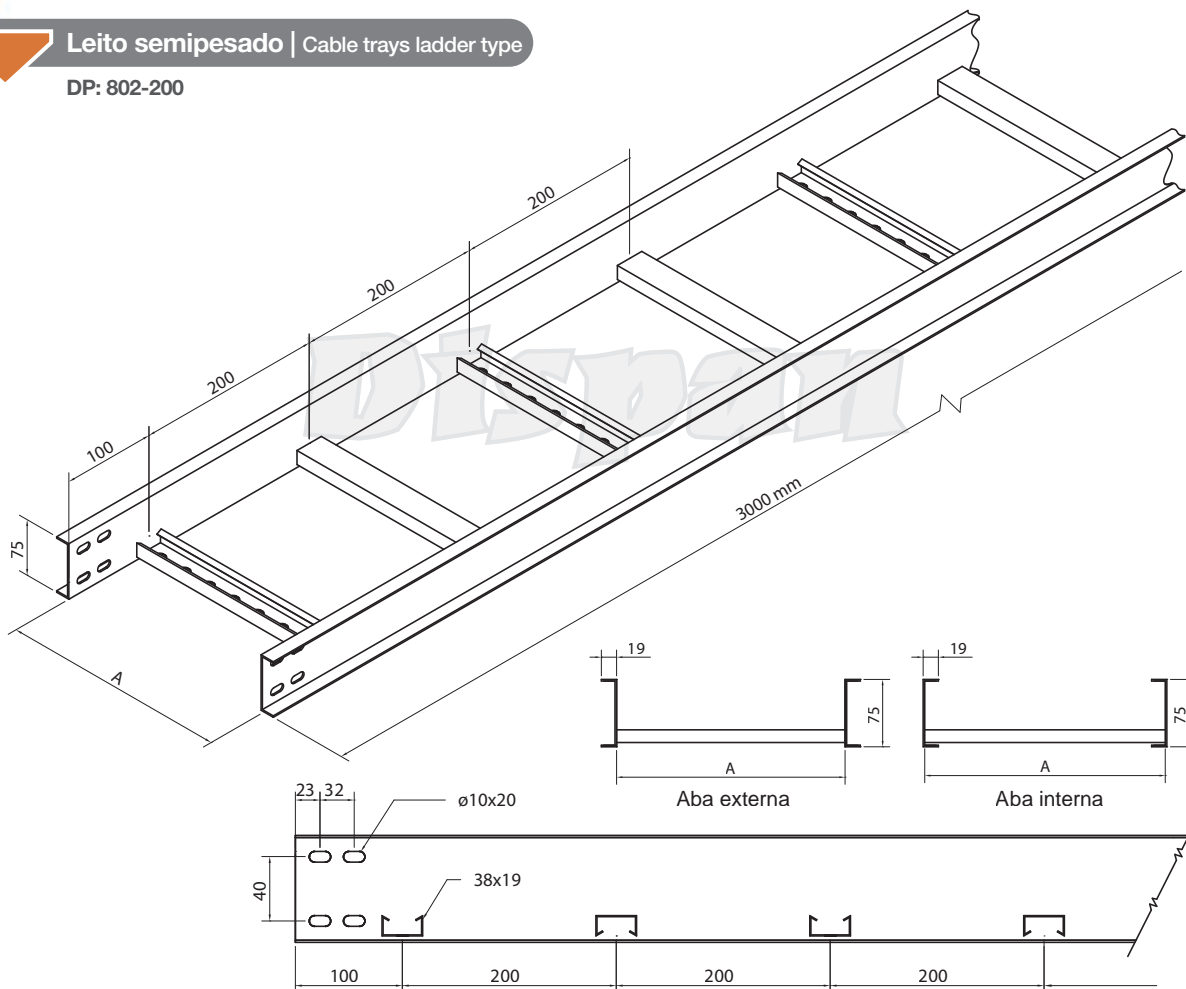

* Obs.: Comprimento padrão - 3000 ou 6000 mm, outras medidas sob consulta.

Carga uniformemente distribuída entre suportes, com material base em AC.
Uniformly distributed loads, between supports.

LARGURA mm Width	PESO POR BARRA Wight KG	Chapa Steel plate		Distância entre suporte Distance between supports / load KG				
		LONGARINA	TRAVESSAS	1000 mm	1500 mm	2000 mm	2500 mm	3000 mm
200	10,5	16	18	960	760	475	360	220
200	13,5	14	16	1000	790	520	400	270
200	16,5	12	14	1100	820	560	430	320
300	11,5	16	18	975	760	480	360	230
300	15,0	14	16	990	780	490	380	250
300	18,5	12	14	1100	815	570	435	330
400	16,5	14	16	1000	795	505	395	265
400	20,5	12	14	1125	825	575	440	345
500	17,5	14	16	1000	795	505	395	265
500	22,0	12	14	1065	795	540	420	315
600	19,0	14	16	995	790	505	395	345
600	24,0	12	14	1065	795	540	420	315
700	20,5	14	16	955	770	485	380	260
700	25,5	12	14	1025	785	545	410	285
800	22,0	14	16	955	770	485	380	260
800	27,5	12	14	1025	785	545	410	285
900	29,5	12	14	1000	775	520	400	275
1000	31,0	12	14	1000	775	520	400	275
1200	35,0	12	14	1000	775	520	400	275

* Pesos estimados, somente para cálculos de carga.

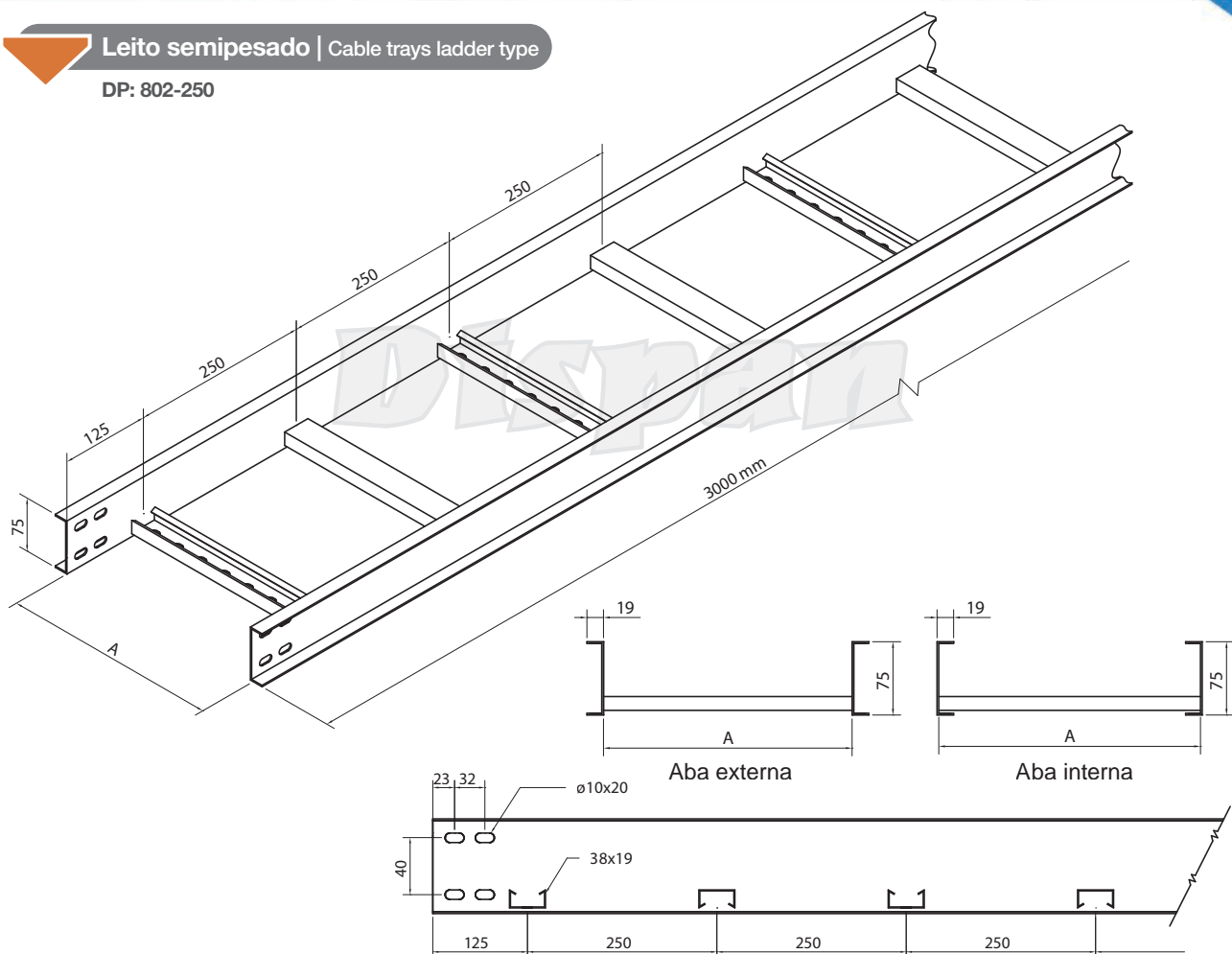

* Obs.: Comprimento padrão - 3000 ou 6000 mm, outras medidas sob consulta.

Carga uniformemente distribuída entre suportes, com material base em AC. Uniformly distributed loads, between supports.								
LARGURA mm Width	PESO POR BARRA Wight KG	Chapa Steel plate		Distância entre suporte Distance between supports / load KG				
		LONGARINA	TRAVESSAS	1000 mm	1500 mm	2000 mm	2500 mm	3000 mm
200	10,5	16	18	950	750	465	350	210
200	13,0	14	16	990	780	510	390	260
200	16,0	12	14	1090	810	552	420	310
300	11,5	16	18	965	750	470	350	220
300	16,0	14	16	980	780	490	380	250
300	17,5	12	14	1095	805	560	425	320
400	14,5	14	16	990	785	495	385	255
400	19,0	12	14	1115	815	565	430	335
500	15,5	14	16	990	785	495	385	255
500	20,5	12	14	1056	785	530	410	305
600	18,0	14	16	985	780	495	385	285
600	22,0	12	14	1056	785	530	410	305
700	19,0	14	16	945	760	475	370	250
700	23,5	12	14	1015	775	535	400	275
800	19,5	14	16	945	760	475	370	250
800	25,0	12	14	1015	775	535	400	275
900	26,0	12	14	995	765	510	390	268
1000	27,5	12	14	995	765	510	390	268
1200	30,5	12	14	995	765	510	390	268

* Pesos estimados, somente para cálculos de carga.

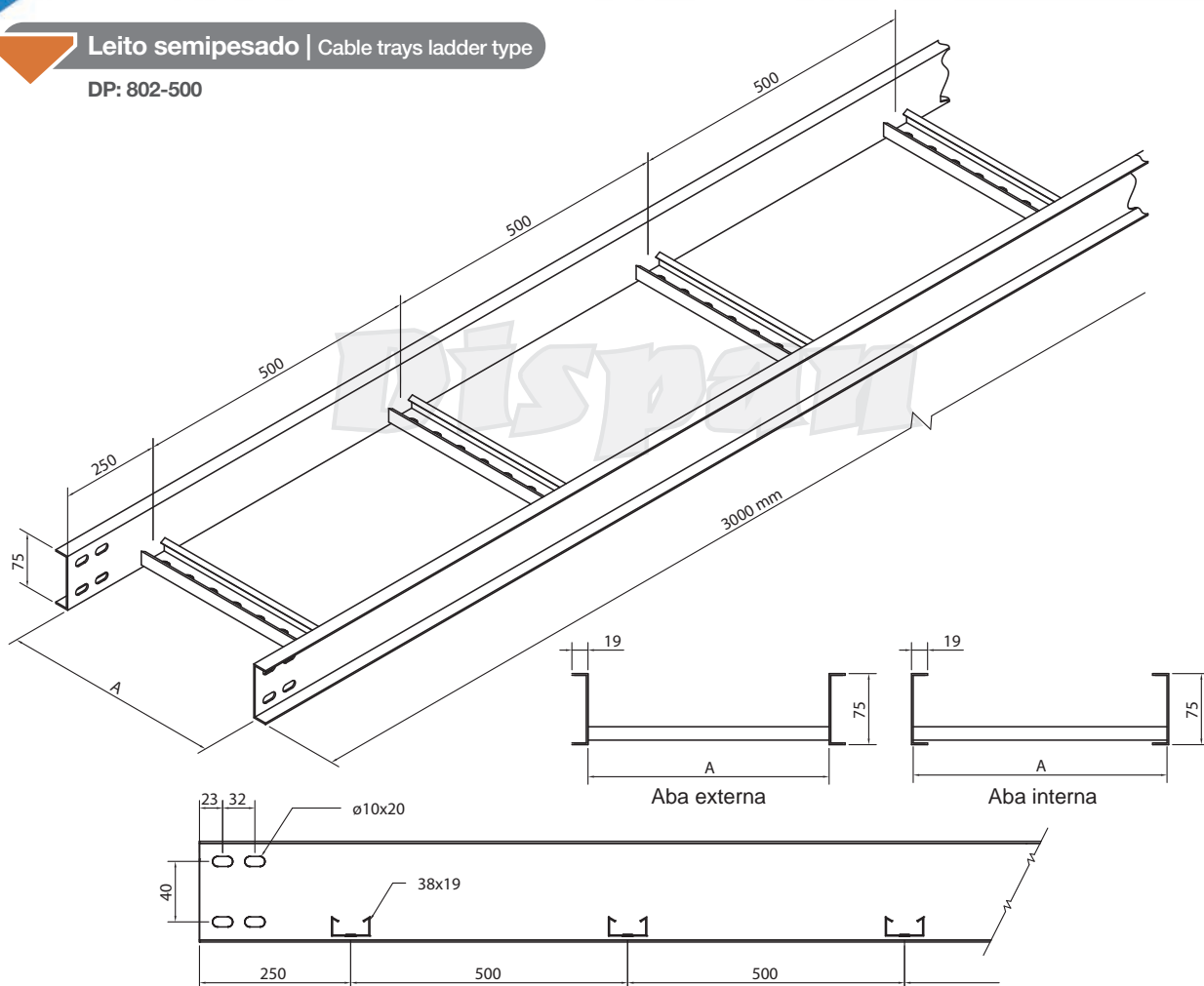

* Obs.: Comprimento padrão - 3000 ou 6000 mm, outras medidas sob consulta.

Carga uniformemente distribuída entre suportes, com material base em AC.
Uniformly distributed loads, between supports.

LARGURA mm Width	PESO POR BARRA Wight KG	Chapa Steel plate		Distância entre suporte Distance between supports / load KG				
		LONGARINA	TRAVESSAS	1000 mm	1500 mm	2000 mm	2500 mm	3000 mm
200	9,0	16	18	930	720	440	330	190
200	11,5	14	16	970	760	490	370	240
200	14,5	12	14	1070	790	530	400	290
300	10,0	16	18	945	730	450	330	200
300	12,5	14	16	960	760	470	360	230
300	15,5	12	14	1070	780	540	405	300
400	11,5	14	16	970	765	475	365	235
400	16,5	12	14	1095	795	545	410	315
500	14,0	14	16	970	765	475	365	235
500	17,0	12	14	1030	765	510	390	285
600	14,5	14	16	965	760	475	365	265
600	18,0	12	14	1030	765	510	390	285
700	15,5	14	16	925	740	455	350	230
700	19,0	12	14	995	755	525	380	255
800	16,0	14	16	925	740	455	350	230
800	20,0	12	14	995	755	525	380	255
900	21,0	12	14	995	755	525	380	255
1000	22,0	12	14	995	755	525	380	255
1200	23,5	12	14	995	755	525	380	255

* Pesos estimados, somente para cálculos de carga.

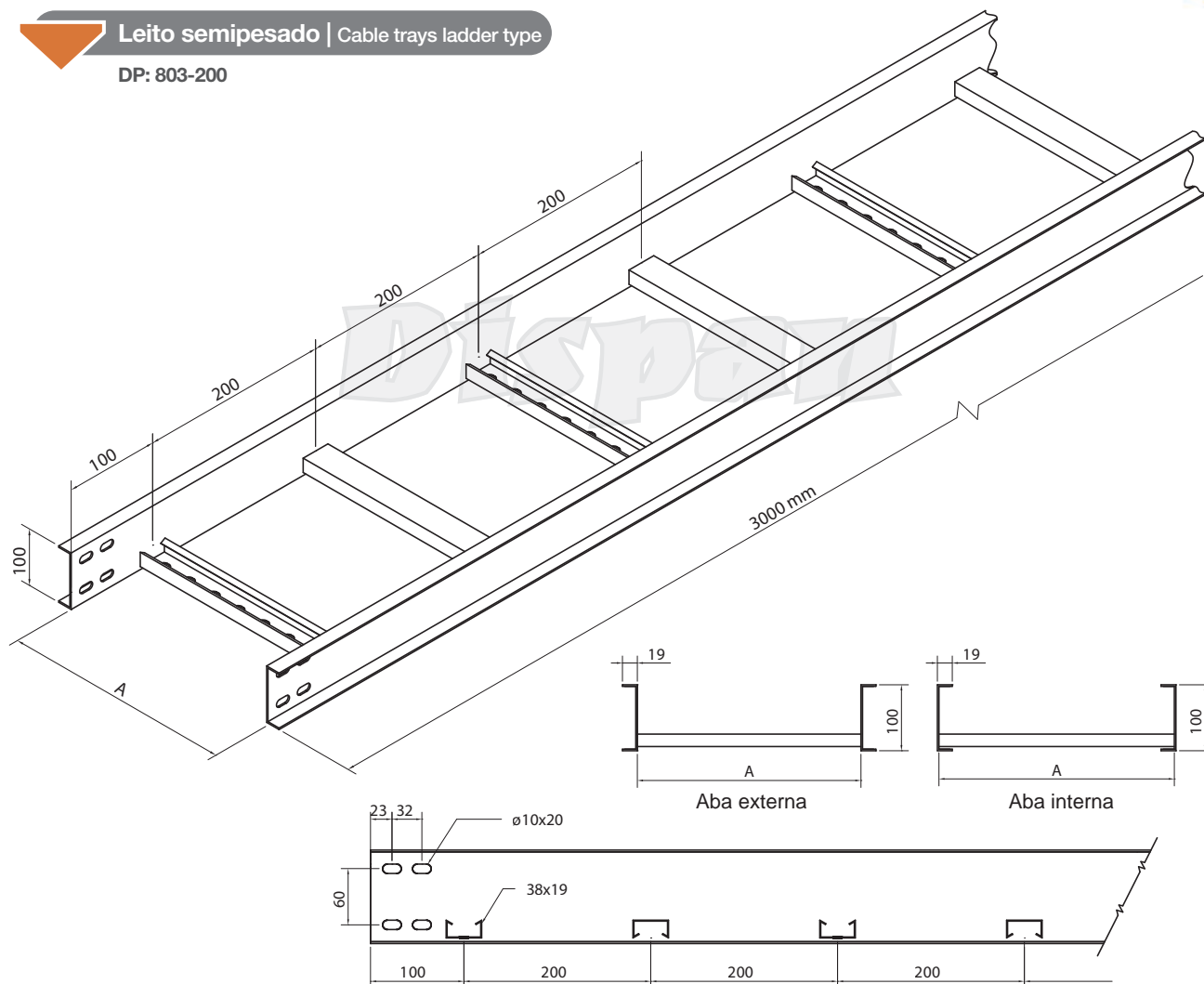

* Obs.: Comprimento padrão - 3000 ou 6000 mm, outras medidas sob consulta.

Carga uniformemente distribuída entre suportes, com material base em AC. Uniformly distributed loads, between supports.								
LARGURA mm Width	PESO POR BARRA Wight KG	Chapa Steel plate		Distância entre suporte Distance between supports / load KG				
		LONGARINA	TRAVESSAS	1000 mm	1500 mm	2000 mm	2500 mm	3000 mm
200	16,0	14	16	1180	950	670	510	350
200	19,5	12	14	1450	1090	750	580	410
300	17,5	14	16	1180	950	670	510	350
300	21,5	12	14	1420	1070	735	560	400
400	19,0	14	16	1180	950	670	510	350
400	23,5	12	14	1420	1070	735	560	400
500	20,0	14	16	1180	950	670	510	350
500	25,0	12	14	1420	1070	735	560	400
600	21,5	14	16	1180	950	670	510	350
600	27,0	12	14	1400	1050	700	535	370
700	23,0	14	16	1180	950	670	510	350
700	28,5	12	14	1400	1050	700	535	370
800	24,5	14	16	1180	950	670	510	350
800	30,5	12	14	1400	1050	700	535	370
900	32,5	12	14	1350	1000	670	480	350
1000	34,0	12	14	1350	1000	670	480	350
1200	37,5	12	14	1350	1000	670	480	350

* Pesos estimados, somente para cálculos de carga.

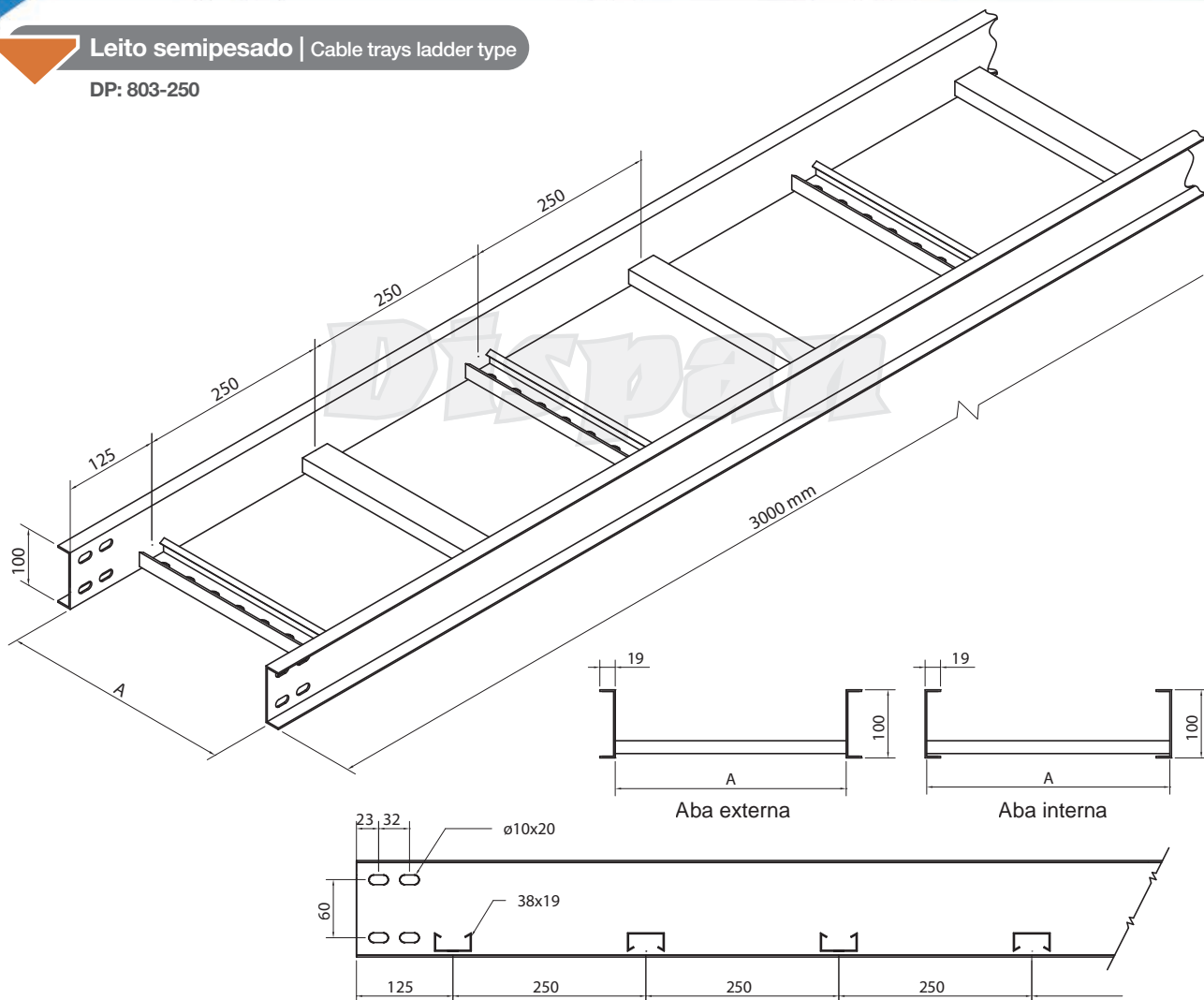

* Obs.: Comprimento padrão - 3000 ou 6000 mm, outras medidas sob consulta.

Carga uniformemente distribuída entre suportes, com material base em AC.
Uniformly distributed loads, between supports.

LARGURA mm Width	PESO POR BARRA Wight KG	Chapa Steel plate		Distância entre suporte Distance between supports / load KG				
		LONGARINA	TRAVESSAS	1000 mm	1500 mm	2000 mm	2500 mm	3000 mm
200	15,0	14	16	1145	910	640	470	320
200	19,0	12	14	1400	1050	710	540	370
300	16,5	14	16	1145	910	640	470	320
300	20,5	12	14	1380	1030	695	525	390
400	18,5	14	16	1145	910	640	470	320
400	23,0	12	14	1380	1030	695	525	390
500	19,0	14	16	1145	910	640	470	320
500	24,0	12	14	1380	1030	695	525	380
600	20,0	14	16	1145	910	640	470	320
600	24,5	12	14	1350	1000	695	500	380
700	21,0	14	16	1145	910	640	470	320
700	26,0	12	14	1350	1000	695	500	380
800	22,5	14	16	1145	910	640	470	320
800	28,5	12	14	1350	990	730	505	385
900	29,5	12	14	1300	970	720	490	400
1000	31,0	12	14	1285	965	675	480	350
1200	34,0	12	14	1285	965	675	480	350

* Pesos estimados, somente para cálculos de carga.

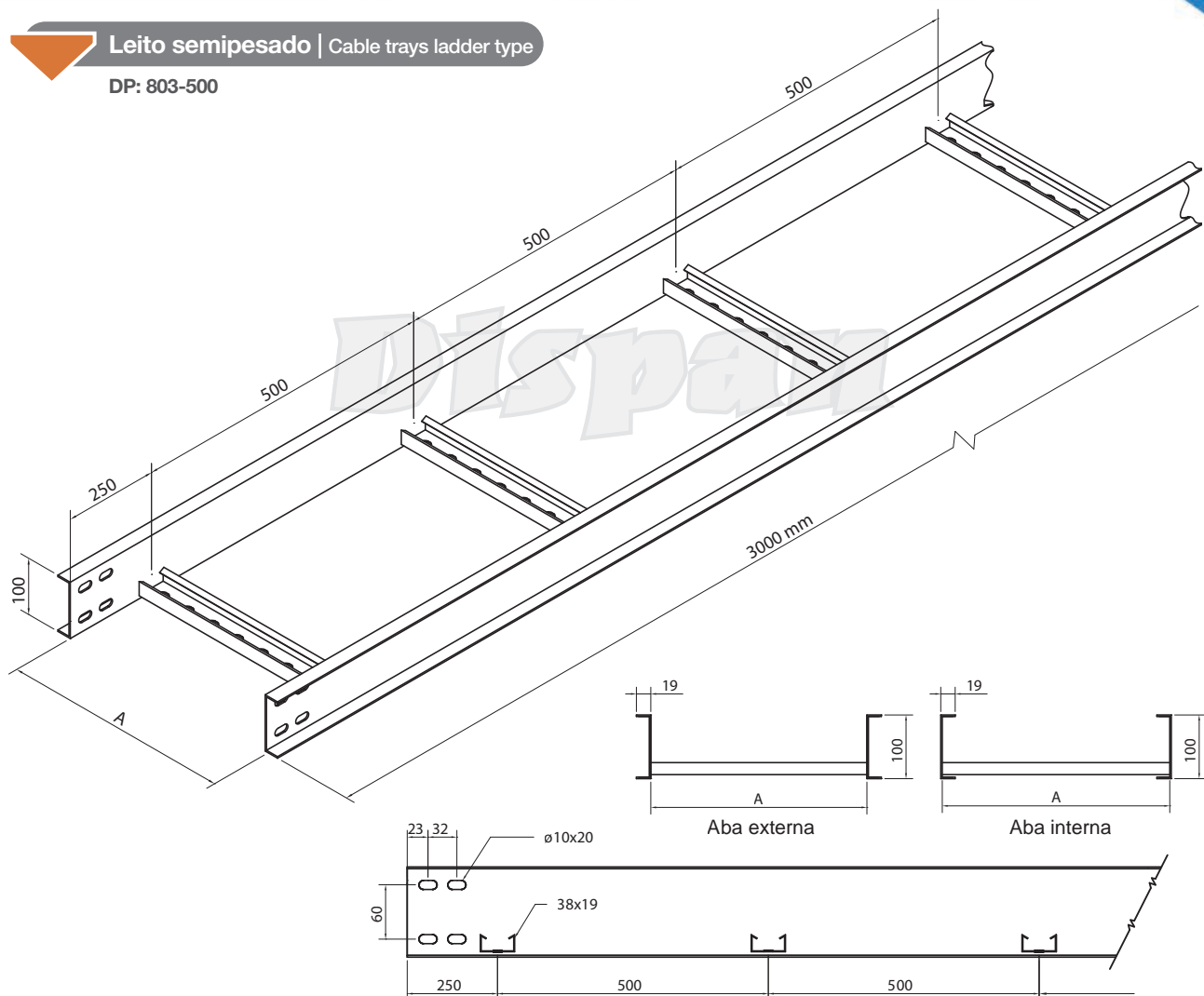

* Obs.: Comprimento padrão - 3000 ou 6000 mm, outras medidas sob consulta.

Carga uniformemente distribuída entre suportes, com material base em AC.
Uniformly distributed loads, between supports.

LARGURA mm Width	PESO POR BARRA Wight KG	Chapa Steel plate		Distância entre suporte Distance between supports / load KG				
		LONGARINA	TRAVESSAS	1000 mm	1500 mm	2000 mm	2500 mm	3000 mm
200	14,0	14	16	1050	800	530	360	210
200	17,0	12	14	1250	920	600	415	260
300	14,5	14	16	1050	800	530	360	210
300	18,0	12	14	1250	920	600	415	260
400	15,0	14	16	1020	780	515	350	205
400	18,5	12	14	1220	900	585	400	250
500	15,5	14	16	1020	780	515	350	205
500	19,5	12	14	1220	900	585	400	250
600	16,0	14	16	1020	780	515	350	205
600	20,0	12	14	1220	900	585	400	250
700	16,7	14	16	1020	780	515	350	205
700	20,5	12	14	1220	900	585	400	250
800	17,5	14	16	1000	765	505	335	195
800	21,5	12	14	1180	870	550	380	230
900	22,5	12	14	1180	870	550	380	230
1000	23,0	12	14	1180	870	550	380	230
1200	24,5	12	14	1140	840	520	350	200

* Pesos estimados, somente para cálculos de carga.

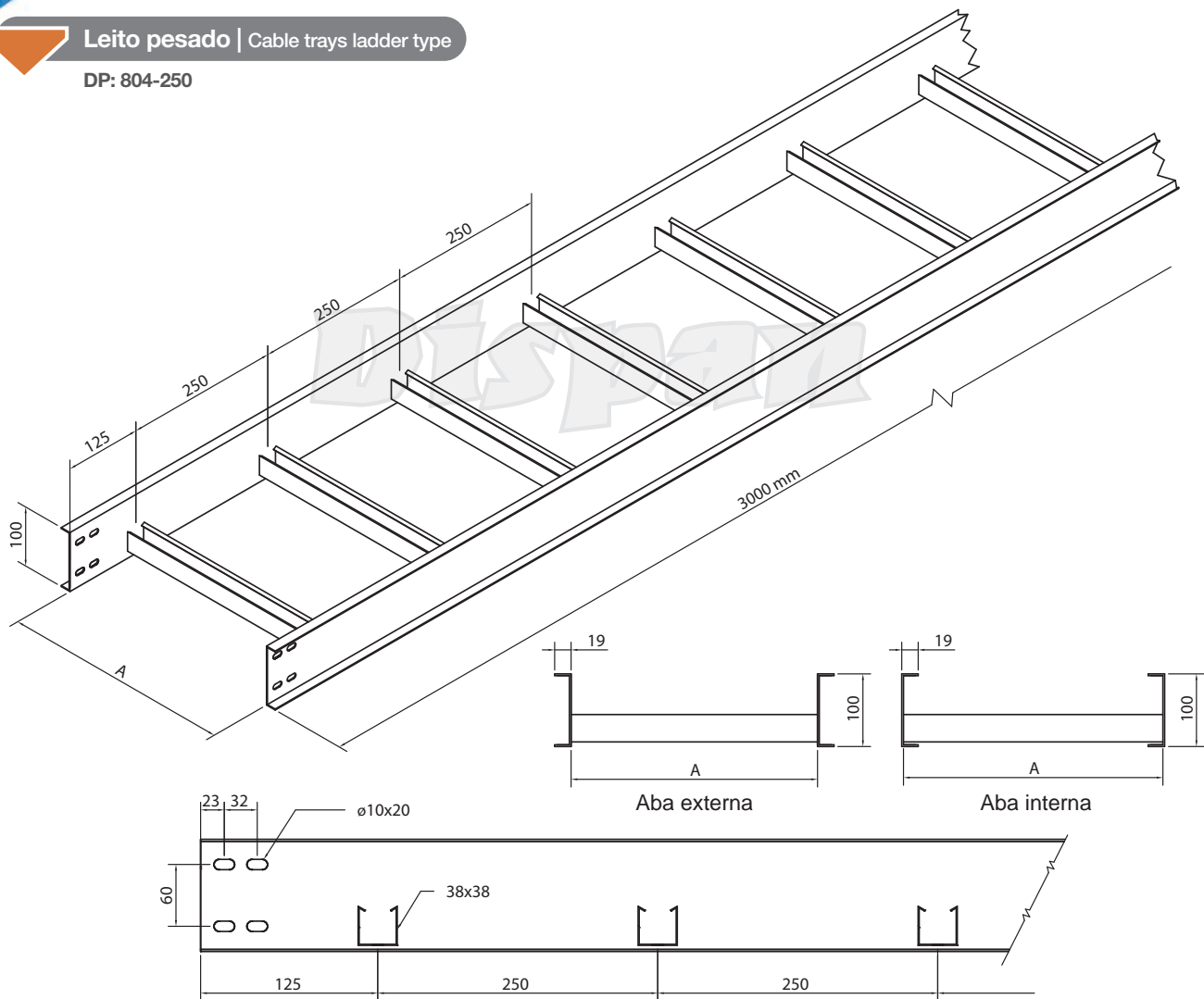

* Obs.: Comprimento padrão - 3000 ou 6000 mm, fabricamos também longarinas com altura de 150 mm, outras medidas sob consulta.

Carga uniformemente distribuída entre suportes, com material base em AC.
Uniformly distributed loads, between supports.

LARGURA mm Width	PESO POR BARRA Wight KG	Chapa Steel plate		Distância entre suporte Distance between supports / load KG				
		LONGARINA	TRAVESSAS	1000 mm	1500 mm	2000 mm	2500 mm	3000 mm
200	16,5	14	16	1320	995	835	655	450
200	20,5	12	14	1850	1425	1050	835	610
300	18,0	14	16	1320	995	835	655	450
300	22,5	12	14	1850	1425	1050	835	610
400	19,5	14	16	1320	995	835	655	450
400	24,5	12	14	1850	1425	1050	835	610
500	21,5	14	16	1320	995	835	655	450
500	27,0	12	14	1850	1425	1050	835	610
600	23,0	14	16	1320	995	835	655	450
600	29,0	12	14	1850	1425	1050	835	610
700	25,0	14	16	1320	995	835	655	450
700	31,0	12	14	1850	1425	1050	835	610
800	33,5	12	14	1910	1445	1090	855	635
900	35,5	12	14	1910	1445	1090	855	635
1000	38,0	12	14	1910	1445	1090	855	635
1200	42,5	12	14	1910	1445	1090	855	635

* Pesos estimados, somente para cálculos de carga.

Leito pesado | Cable trays ladder type

DP: 804-500

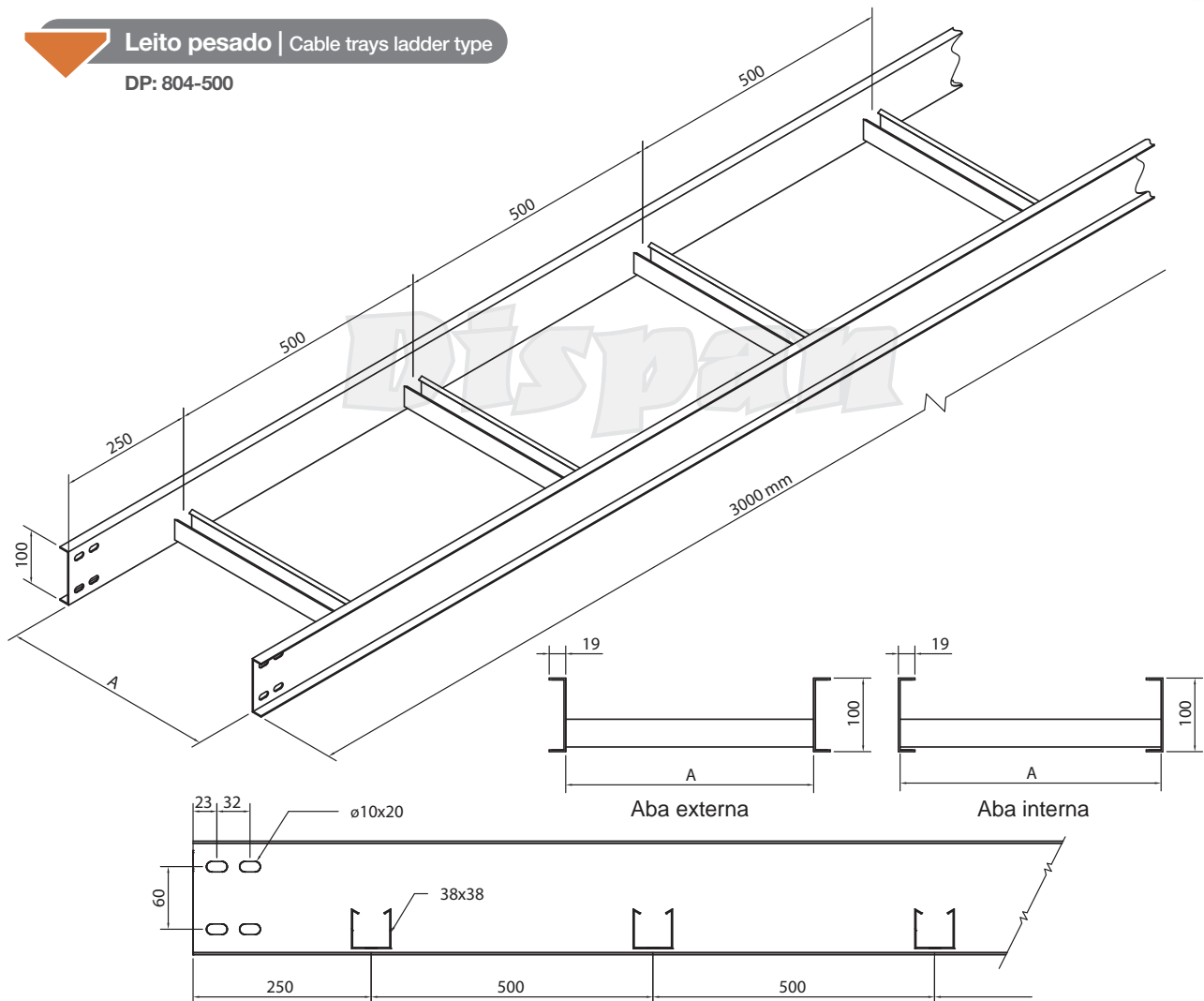

* Obs.: Comprimento padrão - 3000 ou 6000 mm, fabricamos também longarinas com altura de 150 mm, outras medidas sob consulta.

Carga uniformemente distribuída entre suportes, com material base em AC.
Uniformly distributed loads, between supports.

LARGURA mm Width	PESO POR BARRA Wight KG	Chapa Steel plate		Distância entre suporte Distance between supports / load KG				
		LONGARINA	TRAVESSAS	1000 mm	1500 mm	2000 mm	2500 mm	3000 mm
200	14,5	14	16	1280	845	680	505	370
200	18,0	12	14	1760	1250	860	640	490
300	15,5	14	16	1305	895	705	520	395
300	18,5	12	14	1760	1250	860	640	490
400	16,0	14	16	1300	855	700	510	380
400	22,0	12	14	1790	1310	1100	685	580
500	17,0	14	16	1300	855	700	510	380
500	23,5	12	14	1810	1250	1060	625	550
600	18,0	14	16	1300	855	700	510	380
600	25,0	12	14	1810	1250	1060	625	550
700	18,5	14	16	1300	855	700	510	380
700	26,5	12	14	1810	1185	950	605	450
800	28,0	12	14	1800	1185	950	605	450
900	29,5	12	14	1920	1185	950	605	450
1000	31,0	12	14	1780	1140	830	585	425
1200	34,0	12	14	1780	1140	830	585	425

* Pesos estimados, somente para cálculos de carga.

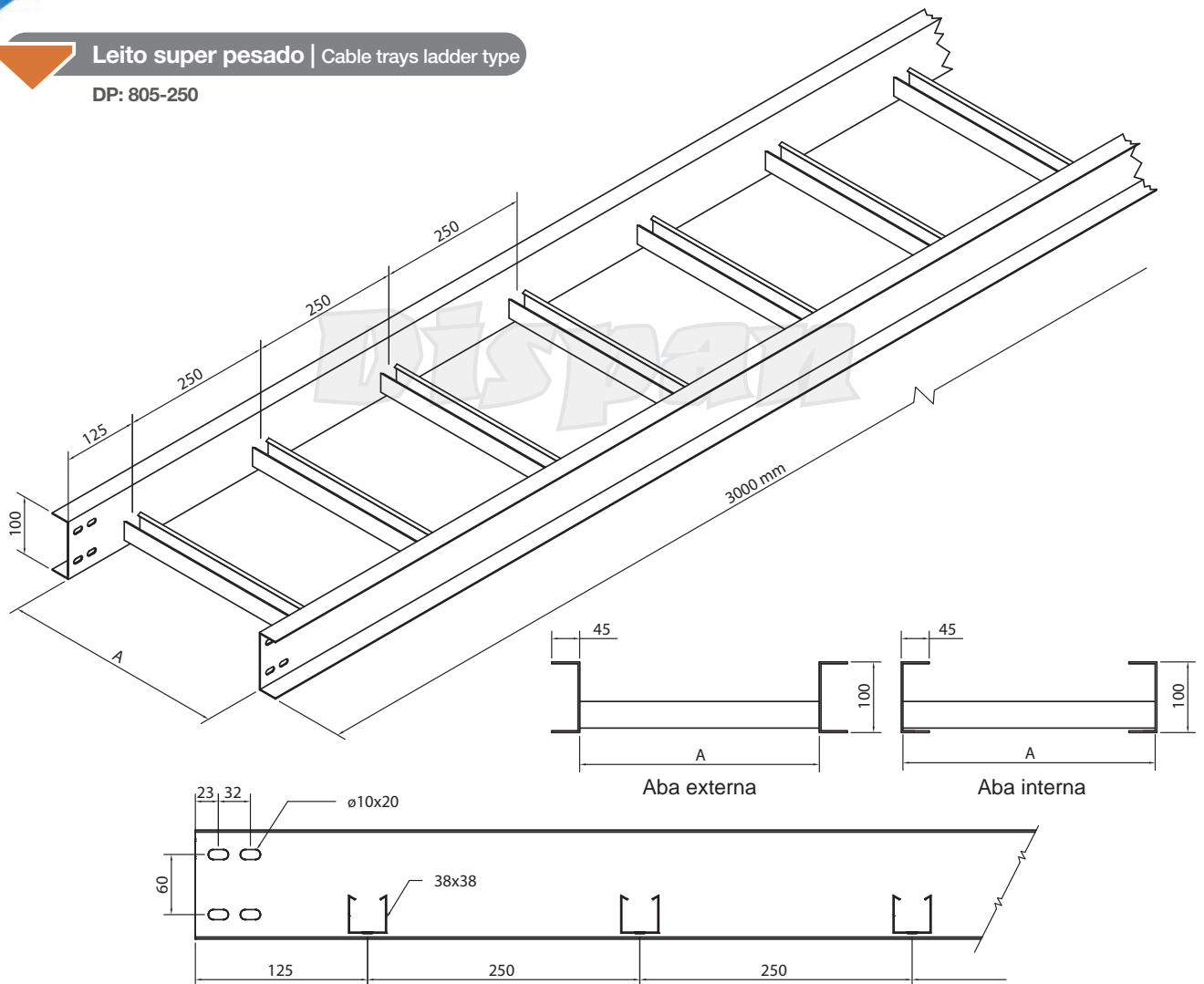

* Obs.: Comprimento padrão - 3000 ou 6000 mm, fabricamos também longarinas com altura de 150 mm, outras medidas sob consulta.

Carga uniformemente distribuída entre suportes, com material base em AC.
Uniformly distributed loads, between supports.

LARGURA mm Width	PESO POR BARRA Wight KG	Chapa Steel plate		Distância entre suporte Distance between supports / load KG				
		LONGARINA	TRAVESSAS	1000 mm	1500 mm	2000 mm	2500 mm	3000 mm
200	21,5	14	16	1525	1205	950	735	620
200	26,5	12	14	2900	2120	1480	1085	760
300	23,0	14	16	1525	1205	950	735	620
300	28,5	12	14	2900	2120	1480	1085	760
400	24,5	14	16	1525	1205	950	735	620
400	31,0	12	14	2900	2120	1480	1085	760
500	26,5	14	16	1525	1205	950	735	620
500	33,0	12	14	2900	2120	1480	1085	760
600	28,0	14	16	1525	1205	950	735	620
600	35,5	12	14	2900	2120	1480	1085	760
700	30,0	14	16	1525	1205	950	735	620
700	37,5	12	14	2900	2120	1480	1085	760
800	39,5	12	14	2750	2050	1400	990	730
900	42,0	12	14	2680	1850	1375	950	705
1000	44,0	12	14	2680	1850	1375	950	705
1200	48,5	12	14	2680	1850	1375	950	705

* Pesos estimados, somente para cálculos de carga.

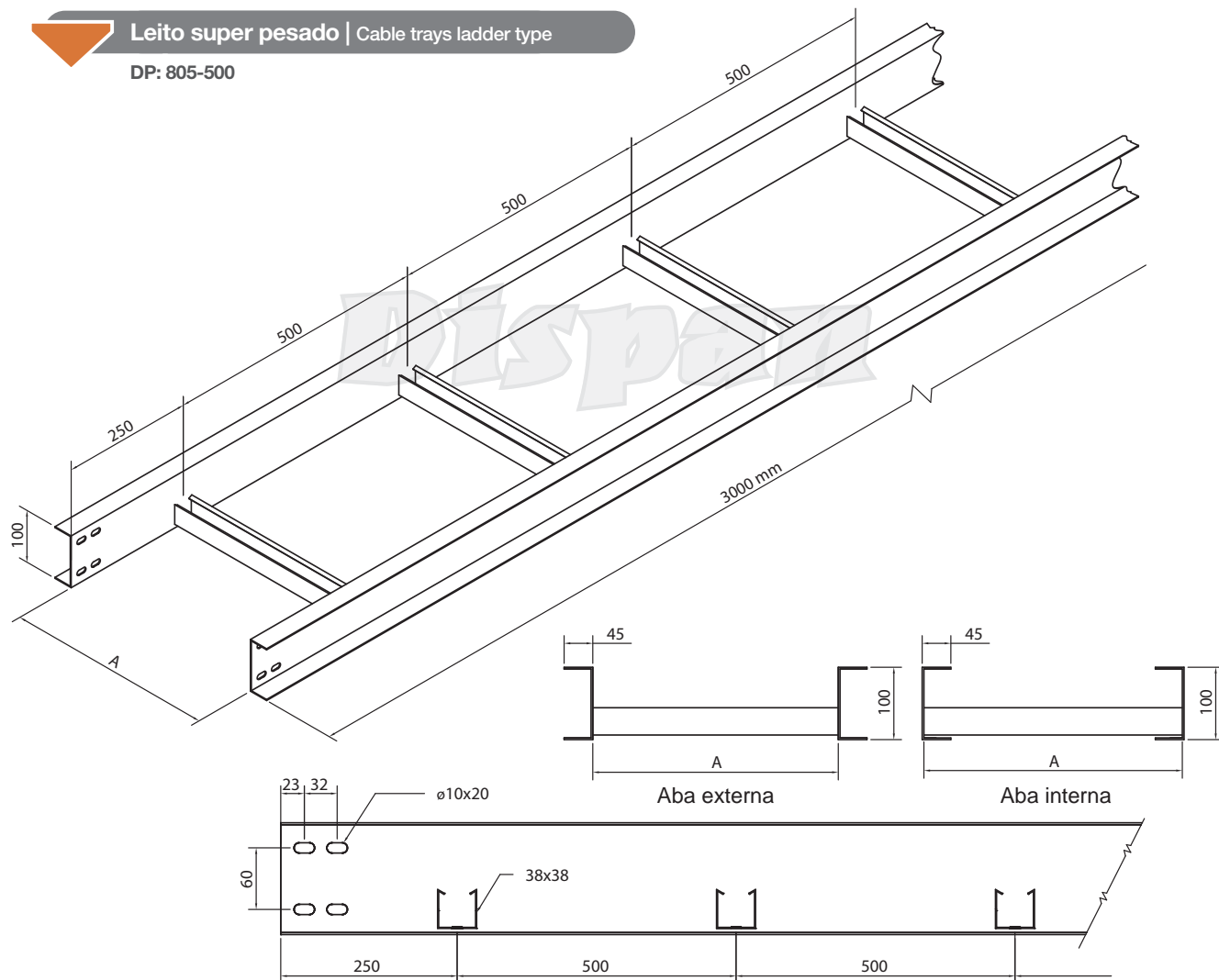

* Obs.: Comprimento padrão - 3000 ou 6000 mm, fabricamos também longarinas com altura de 150 mm, outras medidas sob consulta.

Carga uniformemente distribuída entre suportes, com material base em AC.
Uniformly distributed loads, between supports.

LARGURA mm Width	PESO POR BARRA Wight KG	Chapa Steel plate		Distância entre suporte Distance between supports / load KG				
		LONGARINA	TRAVESSAS	1000 mm	1500 mm	2000 mm	2500 mm	3000 mm
200	19,5	14	16	1380	950	810	625	350
200	24,6	12	14	2050	1510	1070	1775	565
300	20,5	14	16	1380	950	810	625	350
300	25,5	12	14	2050	1510	1070	1775	565
400	21,5	14	16	1380	950	810	625	350
400	26,5	12	14	2000	1470	1010	720	535
500	22,0	14	16	1380	950	810	625	350
500	27,5	12	14	2000	1470	1010	720	535
600	23,0	14	16	1380	950	810	625	350
600	28,5	12	14	2000	1470	1010	720	535
700	24,0	14	16	1400	985	825	635	372
700	29,5	12	14	2000	1470	1010	720	535
800	24,5	14	16	1400	985	825	635	372
800	30,5	12	14	1900	1350	970	680	490
900	25,5	14	16	1400	985	825	635	372
900	31,5	12	14	1900	1350	970	680	490
1000	33,0	12	14	1900	1350	970	680	490
1100	34,0	12	14	1850	1350	950	660	480
1200	35,5	12	14	1850	1350	950	660	480

* Pesos estimados, somente para cálculos de carga.

Como solicitar conexões para leitos

How to specify connections for cable ladder type.

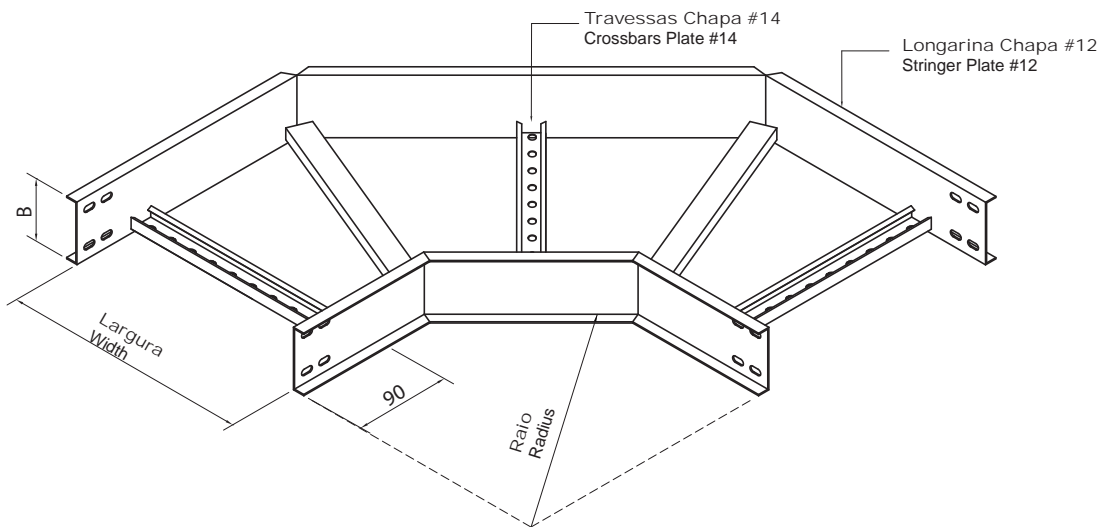

Exemplo

Example

DP811 / 803-250 - AC - GF - AE - 400 - 12/14 - R 320

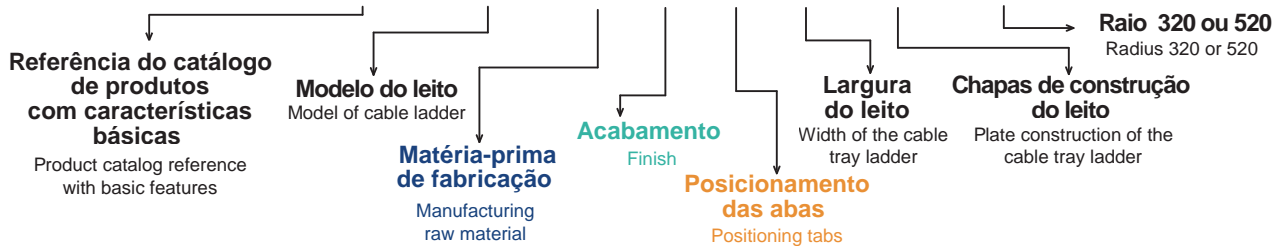

Horizontal bend 90°

Matéria-prima base

Raw material base

- AC - Aço carbono**
Carbon Steel
- AI - Aço inox**
Stainless Steel
- AL - Alumínio**
Aluminum

Acabamento aplicado na matéria-prima em base de aço carbono

Finish applied to the raw material in carbon steel base

- GF - Galvanizado à fogo por imersão**
Hot dip galvanized
- GE - Galvanizado eletrolítico**
Electrolytic galvanized
- NT - Natural**
Natural
- PT - Pintado**
Painting

Posição das abas

- AE - com aba externa**
External tabs
- AI - com aba interna**
Internal tabs

*Para Solicitação da tampa, colocar o código + a letra "T": Exemplo = DP811T

Largura: 400 - Largura do leito desejado (De 100 a 1500 mm).

Width: 400 – width of the wanted cable tray ladder (100 to 1500 mm).

Espessuras de chapas: 12 - Chapa das longarinas | 14 - Chapa das travessas

Plate thickness: 12 - stringers plate | 14 - crossbars plate

Descritivo técnico | Technical description

DP 811 • Curva horizontal 90° para o leito DP 803-250 em aço carbono, galvanização à fogo, aba externa, largura de 400 mm, com longarina de 100 mm e virola de 19 mm em chapa #12 e travessas em perfilado de 38 x 19 mm na chapa #14, raio de curvatura de 320 mm, segmentado.

DP 811 • Horizontal bend of 90° to the carbon steel cable ladder DP 803-250, hot galvanized, external tab, width of 400mm, with stringer of 100mm and ferrule of 19mm in plate #12 and profiled crossbars of 38x19mm in plate #14, radius of curvature of 320mm, segmented.

Nota 1

Ocasionalmente podem ocorrer algumas distorções de medidas em nossas peças, por diversos fatores. Por este motivo damos uma tolerância de 5,0 mm entre as medidas mencionadas no catálogo e as peças reais. Os furos oblongos são feitos exatamente para compensação e ajuste de eventuais diferenças.

Nota 2

Occasionally, it may occur some distortion of measures in our pieces, for several reasons. Because of this, we give a toleration of 5.0 mm between the measures mentioned in this catalog and the real pieces. The slotted holes are made just for clearing and settling of any possible differences.

Nota 2

As conexões para leito, poderão conter cortes, rasgos e soldas para alívio de dobras e conformações construtivas.

Note 2

Connections for cable ladder may contain cuts, rips and solders, for the relief of folds and constructive conformations.

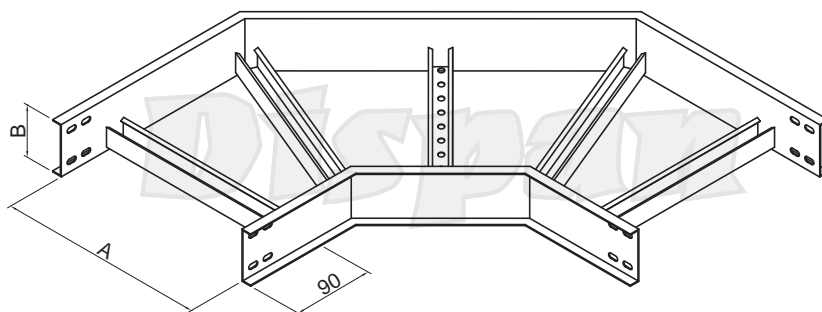

Obs.: Em caso de aba externa considerar cotas "D" e "C" + aba
* aba 19 ou aba 45

* Cotas em mm.

Curva horizontal 15° DP806

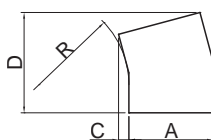

D	C	Raio = 320		Raio = 520	
		A	C	D	
311	34	200	55	474	
337	34	300	55	500	
363	34	400	55	562	
388	34	500	55	552	
414	34	600	55	577	
440	34	700	55	603	
466	34	800	55	629	
492	34	900	55	655	
518	34	1000	55	681	
544	34	1100	55	707	
570	34	1200	55	733	
647	34	1500	55	810	

Curva horizontal 60° DP809

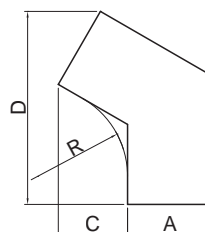

D	C	Raio = 320		Raio = 520	
		A	C	D	
371	114	200	186	495	
457	114	300	186	582	
544	114	400	186	668	
631	114	500	186	755	
717	114	600	186	842	
804	114	700	186	928	
890	114	800	186	1015	
977	114	900	186	1101	
1064	114	1000	186	1188	
1150	114	1100	186	1275	
1237	114	1200	186	1361	
1497	114	1500	186	1621	

Curva horizontal 30° DP807

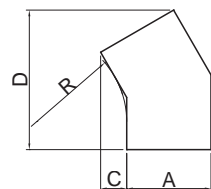

D	C	Raio = 320		Raio = 520	
		A	C	D	
346	66	200	107	501	
396	66	300	107	551	
446	66	400	107	601	
496	66	500	107	651	
546	66	600	107	701	
596	66	700	107	751	
646	66	800	107	801	
696	66	900	107	851	
746	66	1000	107	901	
796	66	1100	107	951	
846	66	1200	107	1001	
996	66	1500	107	1151	

Curva horizontal 75° DP810

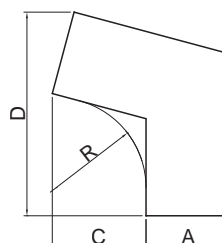

D	C	Raio = 320		Raio = 520	
		A	C	D	
359	127	200	207	463	
455	127	300	207	560	
552	127	400	207	653	
649	127	500	207	753	
745	127	600	207	850	
842	127	700	207	947	
938	127	800	207	1043	
1035	127	900	207	1139	
1132	127	1000	207	1236	
1228	127	1100	207	1336	
1325	127	1200	207	1429	
1615	127	1500	207	1719	

Curva horizontal 45° DP808

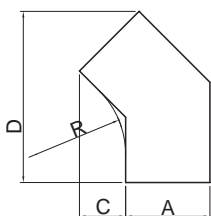

D	C	Raio = 320		Raio = 520	
		A	C	D	
366	93	200	152	508	
437	93	300	152	579	
508	93	400	152	649	
578	93	500	152	720	
649	93	600	152	791	
720	93	700	152	861	
791	93	800	152	932	
861	93	900	152	1003	
932	93	1000	152	1074	
1003	93	1100	152	1144	
1073	93	1200	152	1215	
1285	93	1500	152	1427	

Curva horizontal 90° DP811

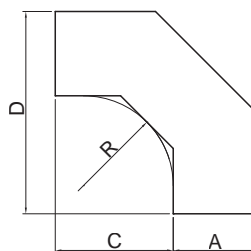

D	C	Raio = 320		Raio = 520	
		A	C	D	
520	320	200	520	720	
620	320	300	520	820	
720	320	400	520	920	
820	320	500	520	1020	
920	320	600	520	1120	
1020	320	700	520	1220	
1120	320	800	520	1320	
1220	320	900	520	1420	
1320	320	1000	520	1520	
1420	320	1100	520	1620	
1520	320	1200	520	1720	
1820	320	1500	520	2020	

Tabela dimensional

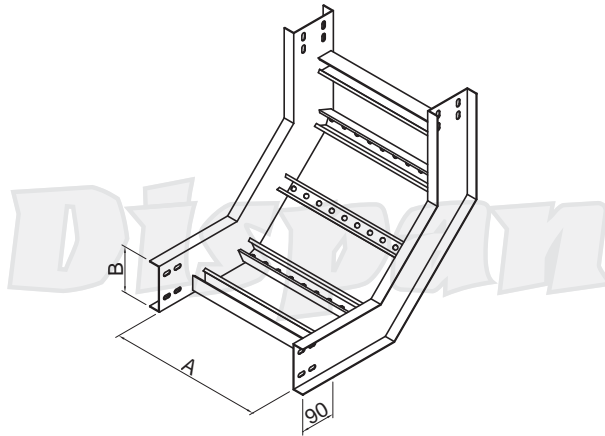

* Cotas em mm.

Curva vertical interna 15° DP812

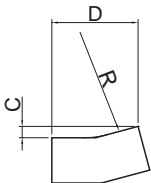

Raio = 320		Raio = 520		
D	C	A	C	D
259	34	200	55	422
259	34	300	55	422
259	34	400	55	422
259	34	500	55	422
259	34	600	55	422
259	34	700	55	422
259	34	800	55	422
259	34	900	55	422
259	34	1000	55	422
259	34	1100	55	422
259	34	1200	55	422
259	34	1500	55	422

Curva vertical interna 60° DP815

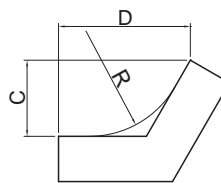

Raio = 320		Raio = 520		
D	C	A	C	D
198	114	200	186	322
198	114	300	186	322
198	114	400	186	322
198	114	500	186	322
198	114	600	186	322
198	114	700	186	322
198	114	800	186	322
198	114	900	186	322
198	114	1000	186	322
198	114	1100	186	322
198	114	1200	186	322
198	114	1500	186	322

Curva vertical interna 30° DP813

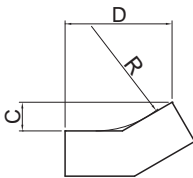

Raio = 320		Raio = 520		
D	C	A	C	D
246	66	200	107	401
246	66	300	107	401
246	66	400	107	401
246	66	500	107	401
246	66	600	107	401
246	66	700	107	401
246	66	800	107	401
246	66	900	107	401
246	66	1000	107	401
246	66	1100	107	401
246	66	1200	107	401
246	66	1500	107	401

Curva vertical interna 75° DP816

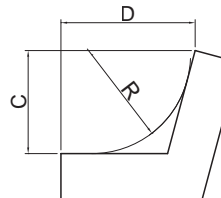

Raio = 320		Raio = 520		
D	C	A	C	D
166	127	200	207	270
166	127	300	207	270
166	127	400	207	270
166	127	500	207	270
166	127	600	207	270
166	127	700	207	270
166	127	800	207	270
166	127	900	207	270
166	127	1000	207	270
166	127	1100	207	270
166	127	1200	207	270
166	127	1500	207	270

Curva vertical interna 45° DP814

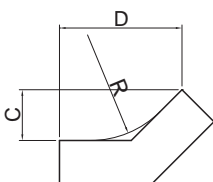

Raio = 320		Raio = 520		
D	C	A	C	D
225	93	200	152	367
225	93	300	152	367
225	93	400	152	367
225	93	500	152	367
225	93	600	152	367
225	93	700	152	367
225	93	800	152	367
225	93	900	152	367
225	93	1000	152	367
225	93	1100	152	367
225	93	1200	152	367
225	93	1500	152	367

Curva vertical interna 90° DP817

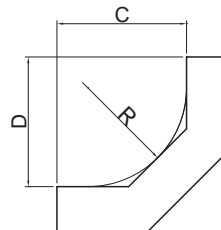

Raio = 320		Raio = 520		
D	C	A	C	D
320	320	200	520	520
320	320	300	520	520
320	320	400	520	520
320	320	500	520	520
320	320	600	520	520
320	320	700	520	520
320	320	800	520	520
320	320	900	520	520
320	320	1000	520	520
320	320	1100	520	520
320	320	1200	520	520
320	320	1500	520	520

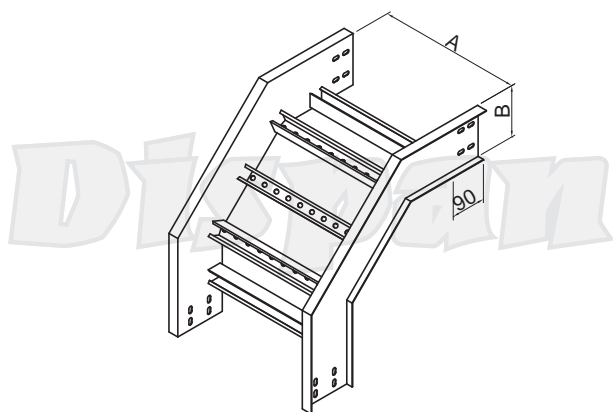

* Cotas em mm.

Curva vertical externa 15° DP818

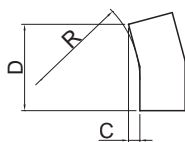

Raio = 320		Raio = 520		
D	C	A	C	D
259	34	200	55	422
259	34	300	55	422
259	34	400	55	422
259	34	500	55	422
259	34	600	55	422
259	34	700	55	422
259	34	800	55	422
259	34	900	55	422
259	34	1000	55	422
259	34	1100	55	422
259	34	1200	55	422
259	34	1500	55	422

Curva vertical externa 60° DP821

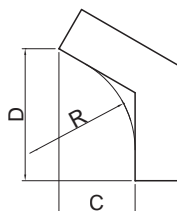

Raio = 320		Raio = 520		
D	C	A	C	D
198	114	200	186	322
198	114	300	186	322
198	114	400	186	322
198	114	500	186	322
198	114	600	186	322
198	114	700	186	322
198	114	800	186	322
198	114	900	186	322
198	114	1000	186	322
198	114	1100	186	322
198	114	1200	186	322
198	114	1500	186	322

Curva vertical externa 30° DP819

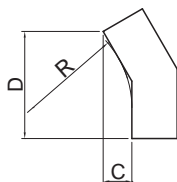

Raio = 320		Raio = 520		
D	C	A	C	D
246	66	200	107	401
246	66	300	107	401
246	66	400	107	401
246	66	500	107	401
246	66	600	107	401
246	66	700	107	401
246	66	800	107	401
246	66	900	107	401
246	66	1000	107	401
246	66	1100	107	401
246	66	1200	107	401
246	66	1500	107	401

Curva vertical externa 75° DP822

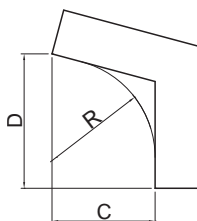

Raio = 320		Raio = 520		
D	C	A	C	D
166	127	200	207	270
166	127	300	207	270
166	127	400	207	270
166	127	500	207	270
166	127	600	207	270
166	127	700	207	270
166	127	800	207	270
166	127	900	207	270
166	127	1000	207	270
166	127	1100	207	270
166	127	1200	207	270
166	127	1500	207	270

Curva vertical externa 45° DP820

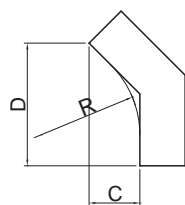

Raio = 320		Raio = 520		
D	C	A	C	D
225	93	200	152	367
225	93	300	152	367
225	93	400	152	367
225	93	500	152	367
225	93	600	152	367
225	93	700	152	367
225	93	800	152	367
225	93	900	152	367
225	93	1000	152	367
225	93	1100	152	367
225	93	1200	152	367
225	93	1500	152	367

Curva vertical externa 90° DP823

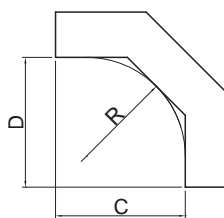

Raio = 320		Raio = 520		
D	C	A	C	D
320	320	200	520	520
320	320	300	520	520
320	320	400	520	520
320	320	500	520	520
320	320	600	520	520
320	320	700	520	520
320	320	800	520	520
320	320	900	520	520
320	320	1000	520	520
320	320	1100	520	520
320	320	1200	520	520
320	320	1500	520	520



Tabela dimensional				
Raio = 320			Raio = 520	
D	C	A	C	D
320	320	200	520	520
320	320	300	520	520
320	320	400	520	520
320	320	500	520	520
320	320	600	520	520
320	320	700	520	520
320	320	800	520	520
320	320	900	520	520
320	320	1000	520	520
320	320	1100	520	520
320	320	1200	520	520
320	320	1500	520	520

Exemplo de montagem de curva de inversão 90°

Typical applications

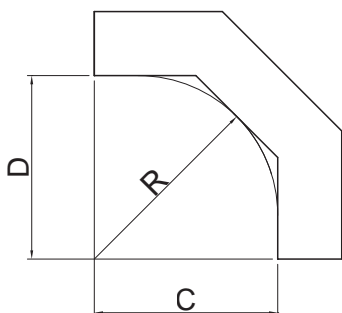
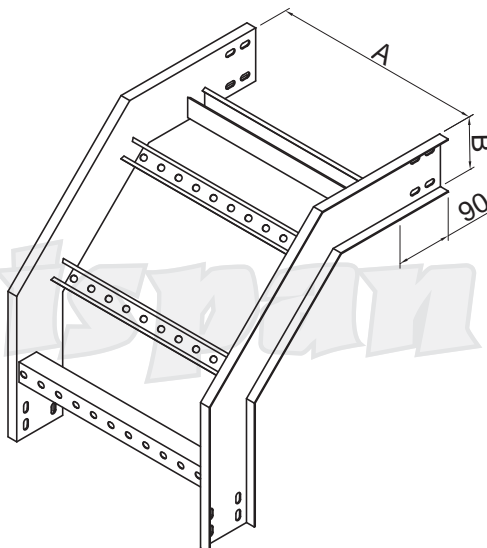
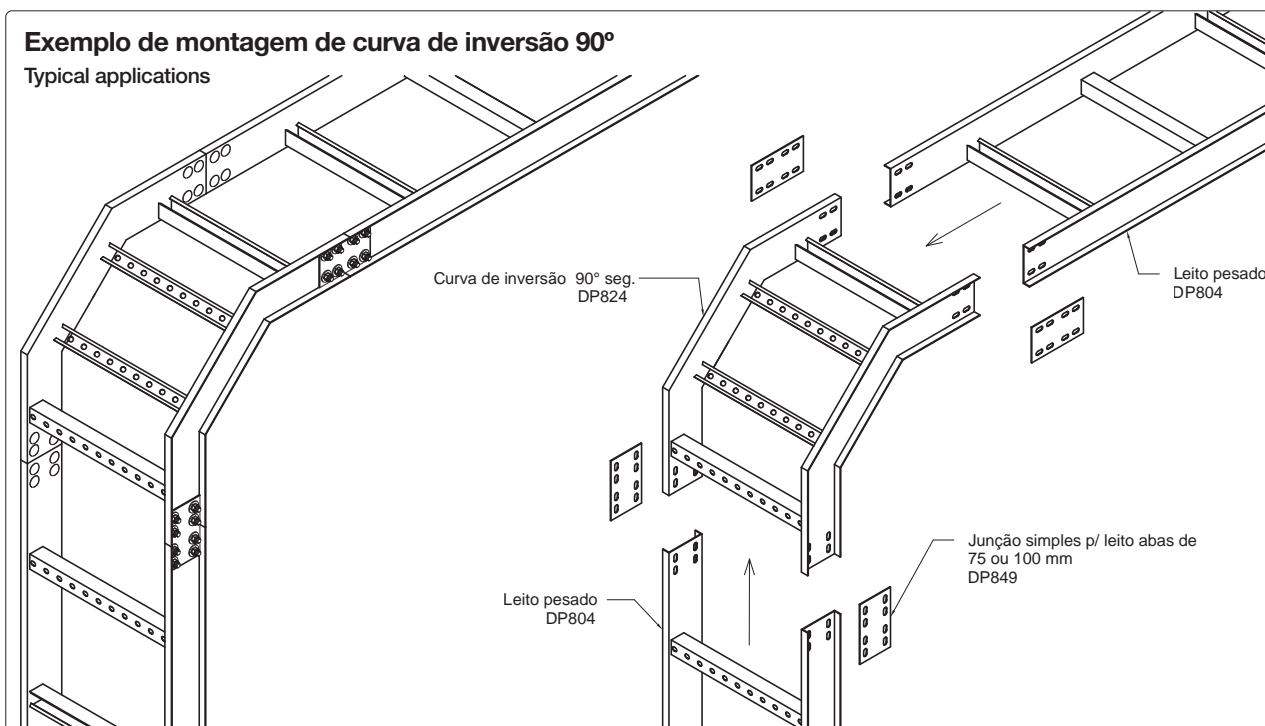

Junção à direita 90° segmentada | Right - hand y - branch

DP: 825

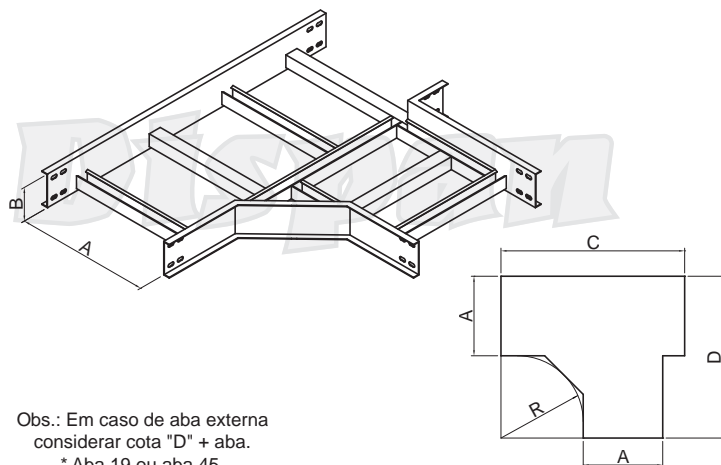

Obs.: Em caso de aba externa considerar cota "D" + aba.
* Aba 19 ou aba 45

Tabela dimensional				
Raio = 320		Raio = 520		
D	C	A	C	D
520	652	200	935	720
620	752	300	1035	820
720	852	400	1135	920
820	952	500	1235	1020
920	1052	600	1335	1120
1020	1152	700	1435	1220
1120	1252	800	1535	1320
1220	1352	900	1635	1420
1320	1452	1000	1735	1520
1420	1552	1100	1835	1620
1520	1652	1200	1935	1720
1820	1952	1500	2235	2020

Curva c/ passagem reta de subida | Bend with ascending straight passage

DP: 826



Tabela dimensional		
Raio = 320	Raio = 520	
C	A	C
320	200	520
320	300	520
320	400	520
320	500	520
320	600	520
320	700	520
320	800	520
320	900	520
320	1000	520
320	1100	520
320	1200	520
320	1500	520

Junção à esquerda 90° segmentada | Left - hand y - branch

DP: 827

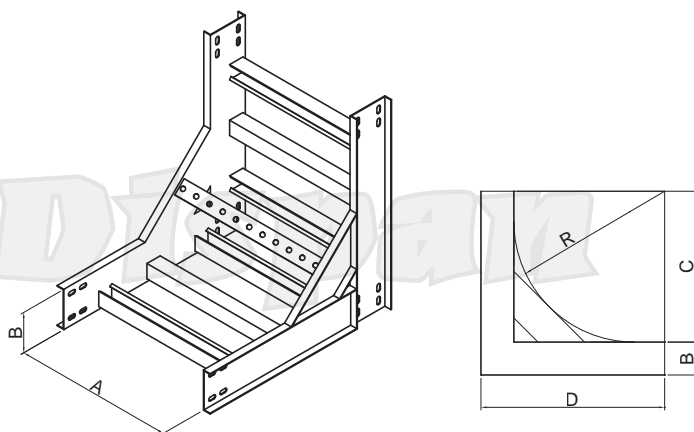
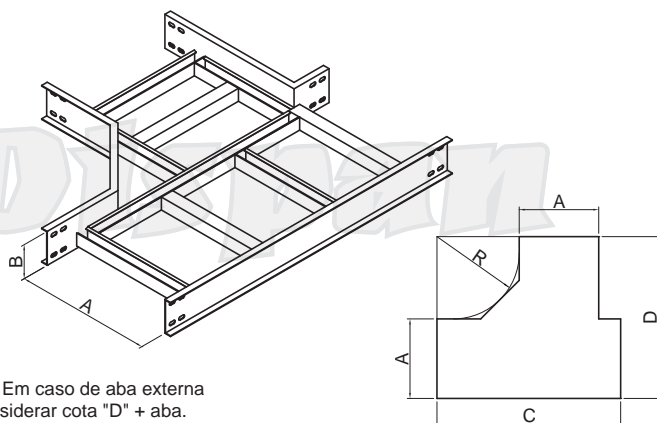

Obs.: Em caso de aba externa considerar cota "D" + aba.
* Aba 19 ou aba 45

Tabela dimensional				
Raio = 320		Raio = 520		
D	C	A	C	D
520	652	200	935	720
620	752	300	1035	820
720	852	400	1135	920
820	952	500	1235	1020
920	1052	600	1335	1120
1020	1152	700	1435	1220
1120	1252	800	1535	1320
1220	1352	900	1635	1420
1320	1452	1000	1735	1520
1420	1552	1100	1835	1620
1520	1652	1200	1935	1720
1820	1952	1500	2235	2020

Curva com passagem reta de descida segmentada | Bend with ascending straight passage

DP: 828



Tabela dimensional		
Raio = 320		Raio = 520
C	A	C
320	200	520
320	300	520
320	400	520
320	500	520
320	600	520
320	700	520
320	800	520
320	900	520
320	1000	520
320	1100	520
320	1200	520
320	1500	520

*D = C + B (De acordo com a aba).

Tê horizontal 90° segmentado | Horizontal tee

DP: 829

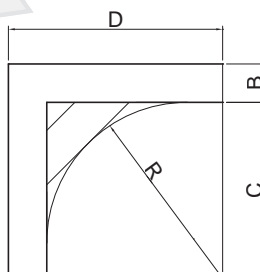
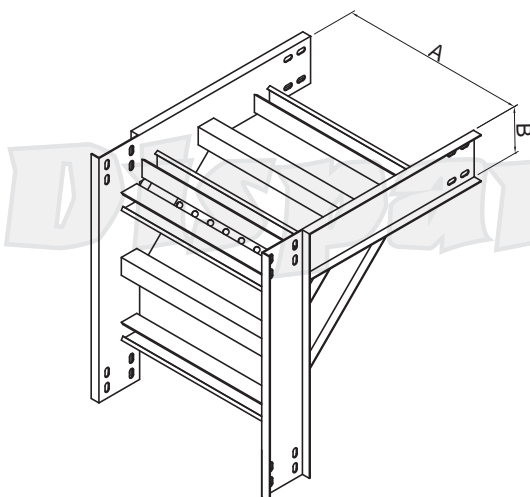
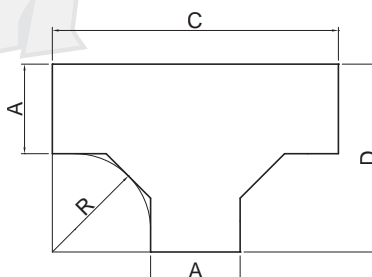
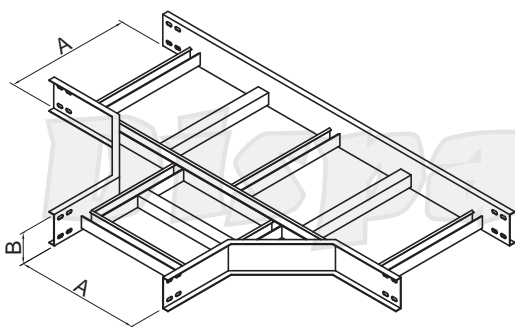

Obs.: Em caso de aba externa considerar cota "D" + aba.
* Aba 19 ou aba 45

Tabela dimensional				
Raio = 320		Raio = 520		
D	C	A	C	D
520	840	200	1240	720
620	940	300	1340	820
720	1040	400	1440	920
820	1140	500	1540	1020
920	1240	600	1640	1120
1020	1340	700	1740	1220
1120	1440	800	1840	1320
1220	1540	900	1940	1420
1320	1640	1000	2040	1520
1420	1740	1100	2140	1620
1520	1840	1200	2240	1720
1820	2140	1500	2540	2020

Cruzeta c/ uma saída reta 90° segmentada | Cross with one straight outlet

DP: 830



Tabela dimensional				
Raio = 320		Raio = 520		
D	C	A	C	D
652	840	200	1240	935
752	940	300	1340	1035
852	1040	400	1440	1135
952	1140	500	1540	1235
1052	1240	600	1640	1335
1152	1340	700	1740	1435
1252	1440	800	1840	1535
1352	1540	900	1940	1635
1452	1640	1000	2040	1735
1552	1740	1100	2140	1835
1652	1840	1200	2240	1935
1952	2140	1500	2540	2235

Cruzeta horizontal segmentada | Horizontal cross

DP: 831

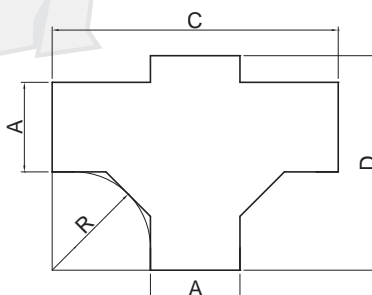
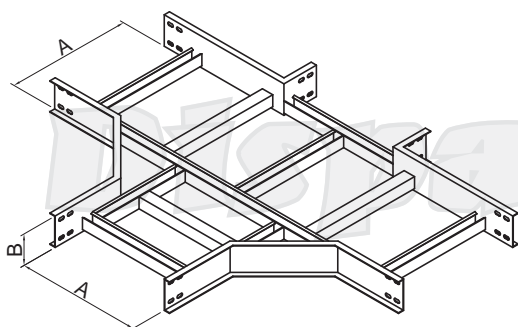

Tabela dimensional		
Raio = 320		Raio = 520
C	A	C
840	200	1240
940	300	1340
1040	400	1440
1140	500	1540
1240	600	1640
1340	700	1740
1440	800	1840
1540	900	1940
1640	1000	2040
1740	1100	2140
1840	1200	2240
2140	1500	2540

Junção à esquerda 45° | Left - hand y - branch

DP: 832

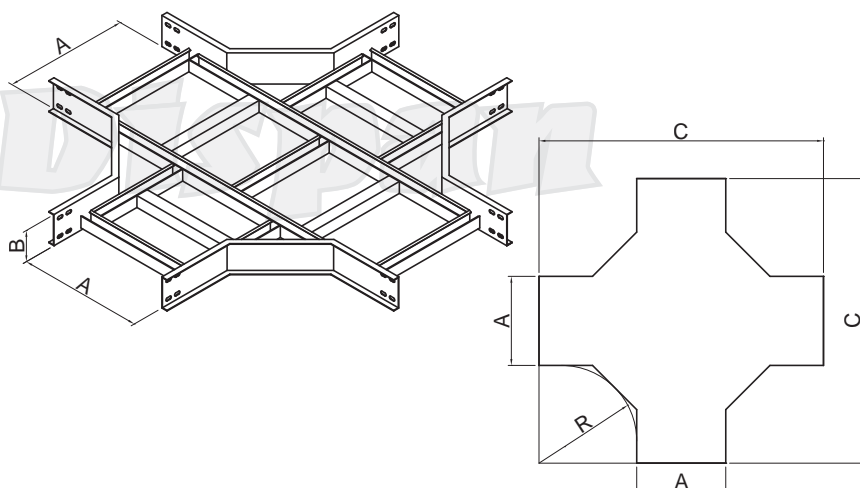
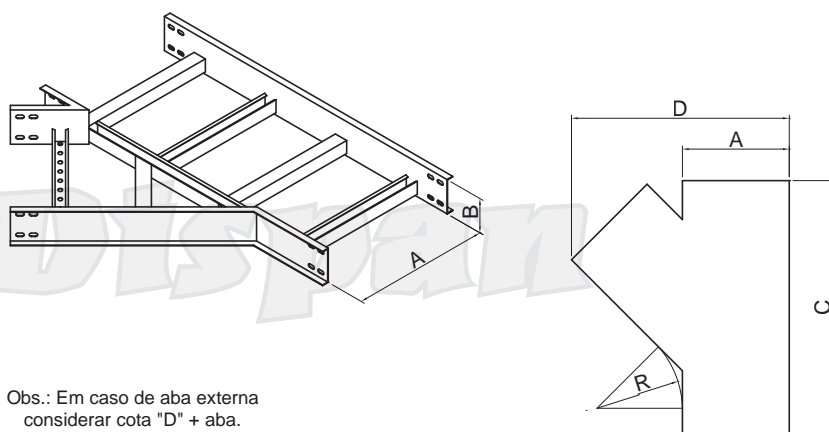

Obs.: Em caso de aba externa considerar cota "D" + aba.

- * Aba 19 = 33 mm
- * Aba 45 = 77 mm

Tabela dimensional				
Raio = 320		Raio = 520		
D	C	A	C	D
473	547	200	713	556
644	688	300	854	727
815	829	400	995	898
985	971	500	1137	1068
1156	1112	600	1278	1239
1327	1254	700	1420	1410
1497	1395	800	1478	1580
1668	1537	900	1703	1751
1839	1678	1000	1844	1922
2010	1819	1100	1985	2093
2180	1961	1200	2127	2263
2692	2385	1500	2551	2775

Junção à direita 45° | Right - hand y - branch

DP: 833

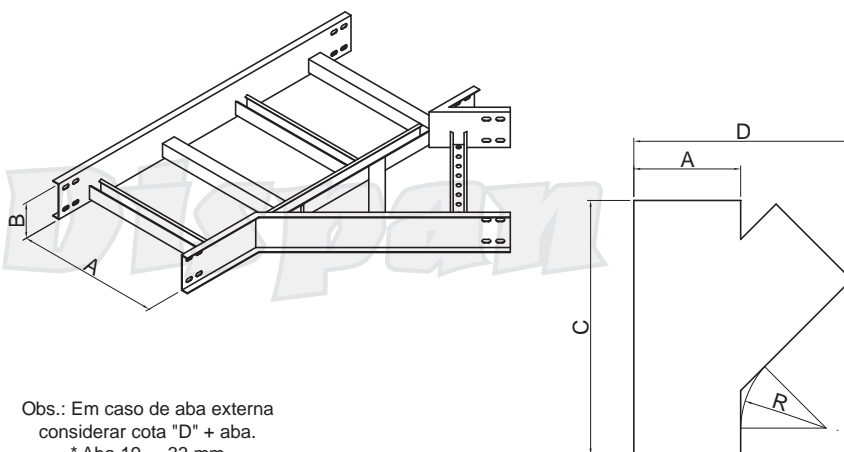

Obs.: Em caso de aba externa considerar cota "D" + aba.

- * Aba 19 = 33 mm
- * Aba 45 = 77 mm

Tabela dimensional				
Raio = 320		Raio = 520		
D	C	A	C	D
473	547	200	713	556
644	688	300	854	727
815	829	400	995	898
985	971	500	1137	1068
1156	1112	600	1278	1239
1327	1254	700	1420	1410
1497	1395	800	1478	1580
1668	1537	900	1703	1751
1839	1678	1000	1844	1922
2010	1819	1100	1985	2093
2180	1961	1200	2127	2263
2692	2385	1500	2551	2775

Tê vertical de subida 90° | Ascending vertical tee

DP: 834



Tabela dimensional		
Raio = 320		Raio = 520
D	A	D
320	200	520
320	300	520
320	400	520
320	500	520
320	600	520
320	700	520
320	800	520
320	900	520
320	1000	520
320	1100	520
320	1200	520
320	1500	520

*C = B + (2 x D) ("B" De acordo com a aba).

Tê vertical de descida 90° | Descending vertical tee

DP: 835

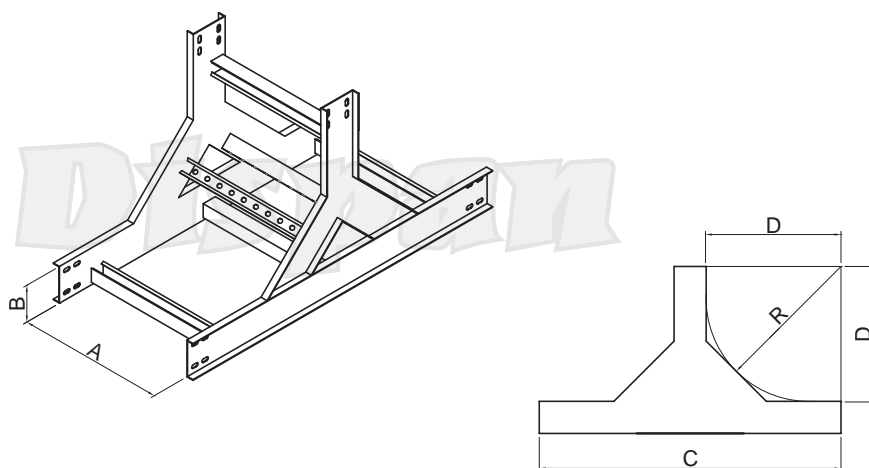

Tabela dimensional		
Raio = 320		Raio = 520
D	A	D
320	200	520
320	300	520
320	400	520
320	500	520
320	600	520
320	700	520
320	800	520
320	900	520
320	1000	520
320	1100	520
320	1200	520
320	1500	520

*C = B + (2 x D) ("B" De acordo com a aba).

Cotovelo reto 90° | 90° elbow

DP: 836

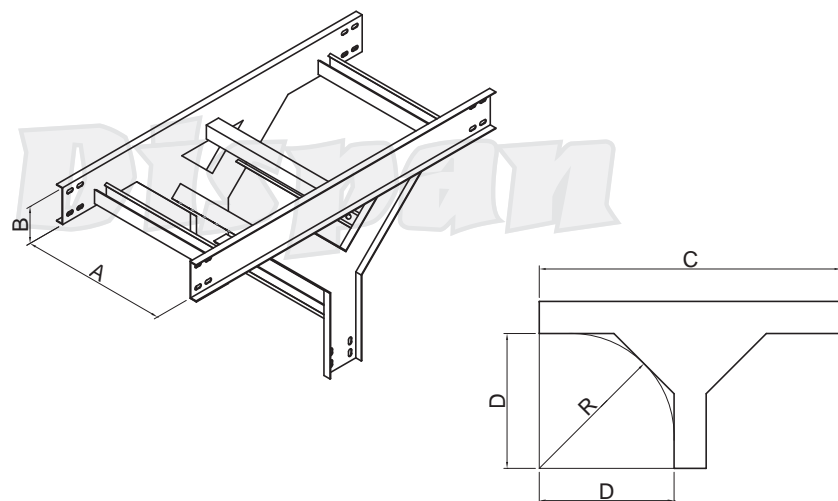

Tabela dimensional	
A	C
200	332
300	432
400	532
500	632
600	732
700	832
800	932
900	1032
1000	1132
1100	1232
1200	1332
1500	1632

Obs.: Em caso de aba externa considerar cota "C" e "A" + aba.

* Aba 19 ou aba 45

Tê reto 90° | Straight tee

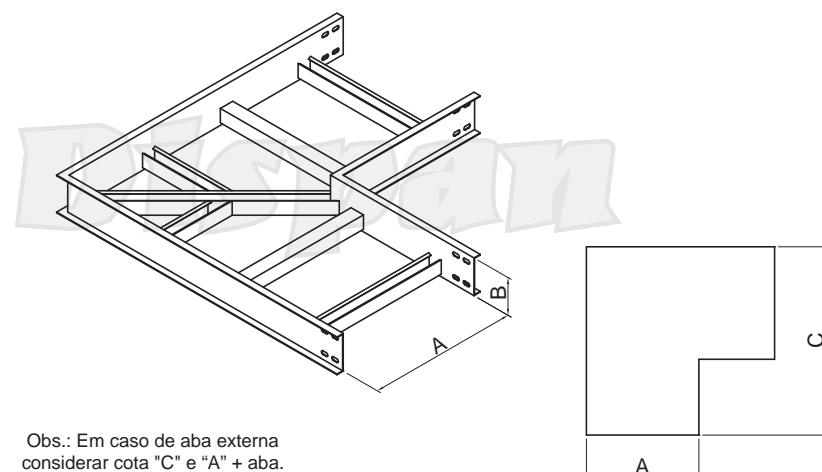
DP: 837



Tabela dimensional		
A	C	D
200	464	332
300	564	432
400	664	532
500	764	632
600	864	732
700	964	832
800	1064	932
900	1164	1032
1000	1264	1132
1100	1364	1232
1200	1464	1332
1500	1764	1632

Obs.: Em caso de aba externa considerar cota "D" + aba.
* Aba 19 ou aba 45

Cruzeta reta 90° | Straight cross

DP: 838

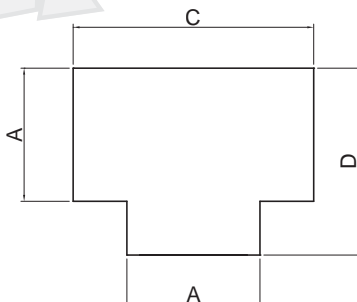
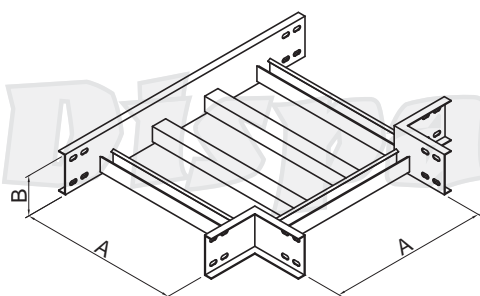

Tabela dimensional	
A	C
200	464
300	564
400	664
500	764
600	864
700	964
800	1064
900	1164
1000	1264
1100	1364
1200	1464
1500	1764

Redução concêntrica | Concentric reducer

DP: 839

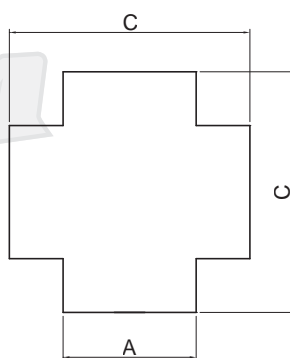
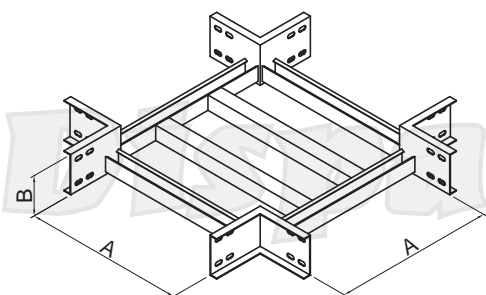
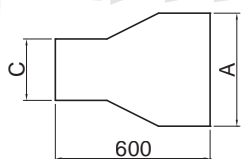
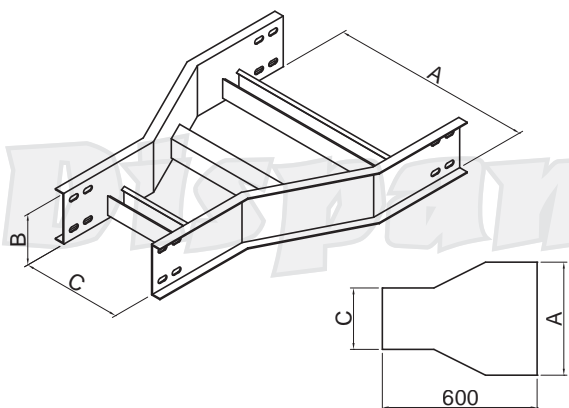

Indicar largura A e C.

Redução à direita | Right - hand reducer

DP: 840

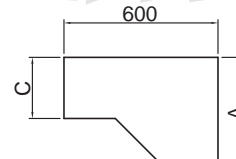
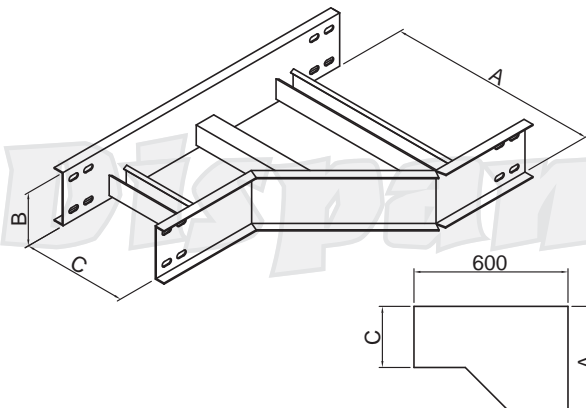

Indicar largura A e C.

Redução à esquerda | left - hand reducer

DP: 841

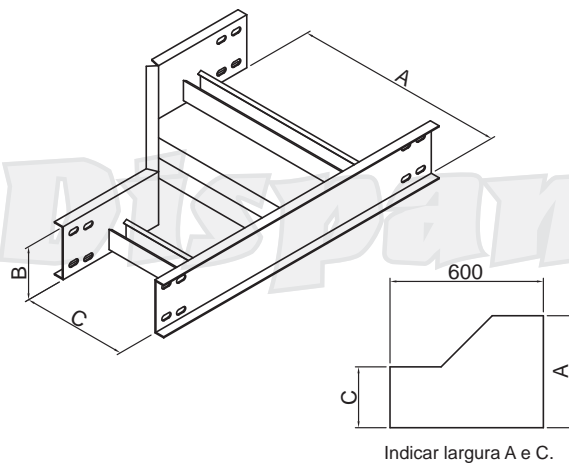

Montagem redução concêntrica | Typical applications

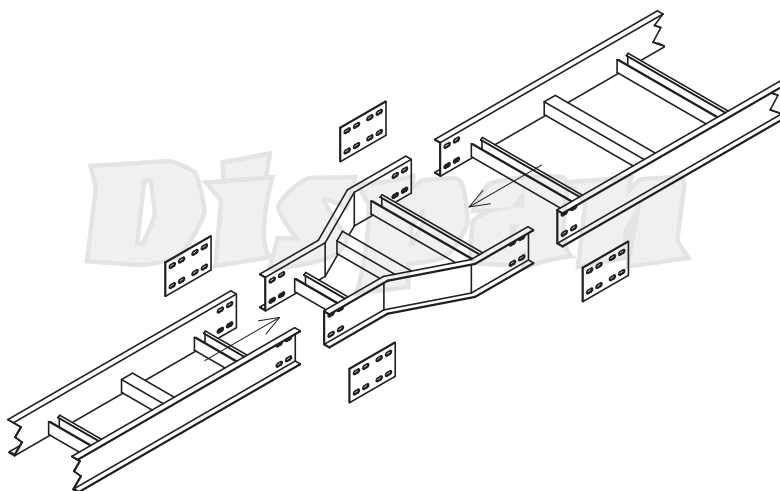

Tê vertical de derivação 90° | 90° lateral vertical descent "T"

DP: 842



Tabela dimensional		
Raio = 320		Raio = 520
D	A	D
320	200	520
320	300	520
320	400	520
320	500	520
320	600	520
320	700	520
320	800	520
320	900	520
320	1000	520
320	1100	520
320	1200	520
320	1500	520

*C = A2 + (2 x D).

*E = D + B ("B" de acordo com a aba)

Redução reta concêntrica | Concentric straight reducer

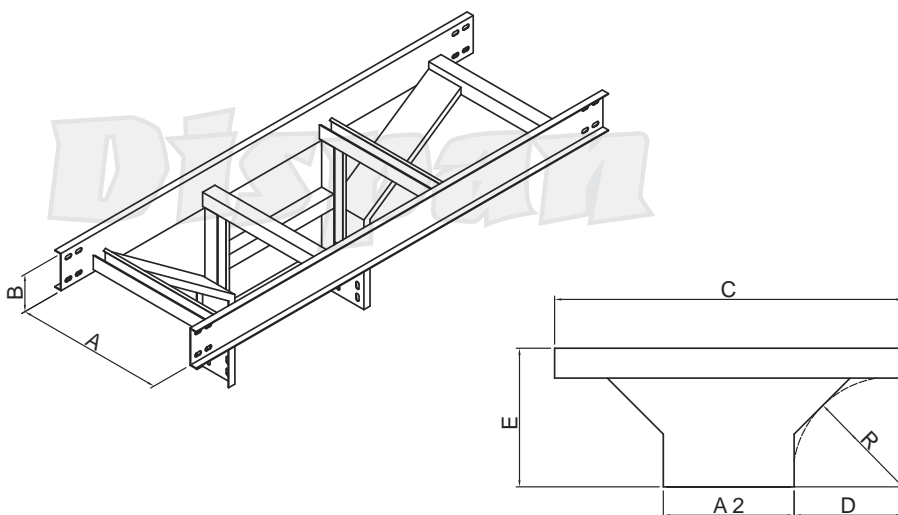
DP: 843

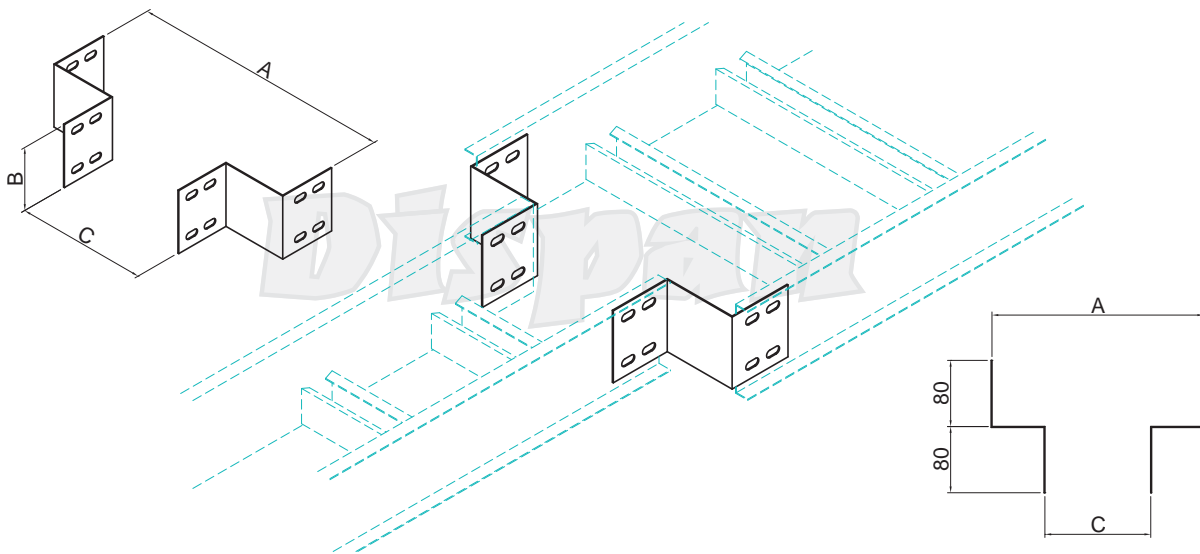

Redução reta excêntrica | Eccentric straight reducer

DP: 843-2

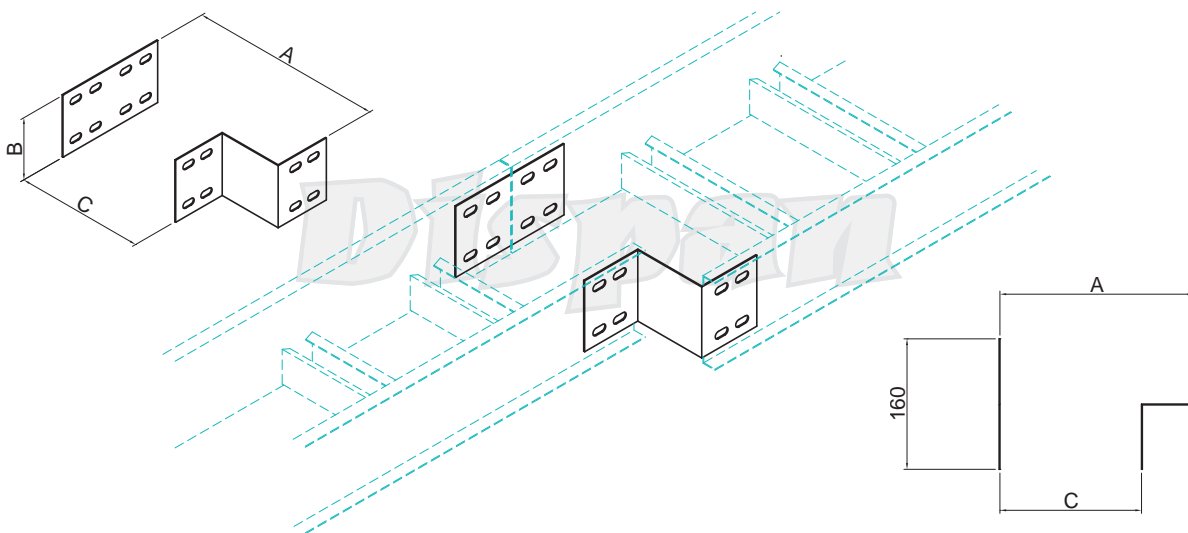

Curva horizontal curvilíneo | Horizontal bends

Tabela dimensional

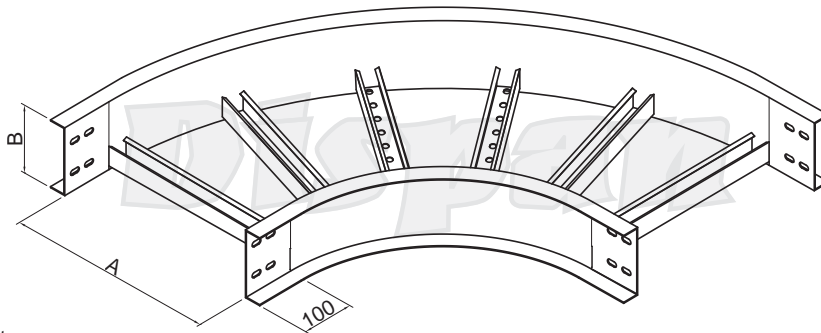

Obs.: Em caso de aba externa considerar cotas "D" e "C" + aba
* aba 19 ou aba 45

* Cotas em mm.

Curva horizontal 15° DP806C

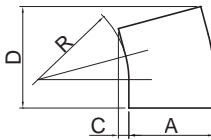

Raio = 320			Raio = 520		
D	C	A	C	D	
331	37	200	43	383	
357	37	300	43	409	
383	37	400	43	434	
409	37	500	43	460	
434	37	600	43	486	
460	37	700	43	512	
486	37	800	43	538	
519	37	900	43	564	
538	37	1000	43	590	
564	37	1100	43	616	
590	37	1200	43	642	
667	37	1500	43	719	

Curva horizontal 60° DP809C

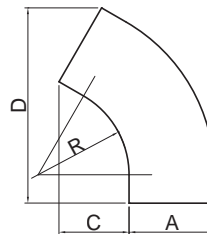

Raio = 320			Raio = 520		
D	C	A	C	D	
600	246	200	346	773	
687	246	300	346	860	
773	246	400	346	947	
860	246	500	346	1033	
944	246	600	346	1120	
1033	246	700	346	1206	
1120	246	800	346	1293	
1206	246	900	346	1380	
1293	246	1000	346	1466	
1380	246	1100	346	1553	
1466	246	1200	346	1639	
1726	246	1500	346	1899	

Curva horizontal 30° DP807C

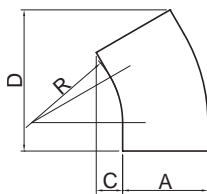

Raio = 320			Raio = 520		
D	C	A	C	D	
446	93	200	119	546	
496	93	300	119	596	
546	93	400	119	646	
596	93	500	119	696	
646	93	600	119	746	
696	93	700	119	796	
746	93	800	119	846	
796	93	900	119	896	
846	93	1000	119	946	
896	93	1100	119	996	
946	93	1200	119	1046	
1046	93	1500	119	1196	

Curva horizontal 75° DP810C

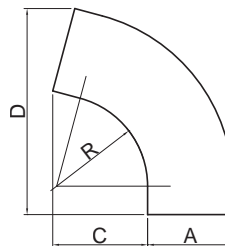

Raio = 320			Raio = 520		
D	C	A	C	D	
628	334	200	482	821	
725	334	300	482	918	
821	334	400	482	1014	
918	334	500	482	1111	
1014	334	600	482	1208	
1111	334	700	482	1304	
1208	334	800	482	1401	
1304	334	900	482	1497	
1401	334	1000	482	1594	
1497	334	1100	482	1690	
1594	334	1200	482	1787	
1884	334	1500	482	2077	

Curva horizontal 45° DP808C

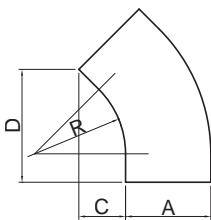

Raio = 320			Raio = 520		
D	C	A	C	D	
538	164	200	223	680	
609	164	300	223	750	
680	164	400	223	821	
750	164	500	223	892	
821	164	600	223	963	
892	164	700	223	1033	
963	164	800	223	1104	
1033	164	900	223	1175	
1104	164	1000	223	1245	
1175	164	1100	223	1316	
1245	164	1200	223	1387	
1457	164	1500	223	1599	

Curva horizontal 90° DP811C

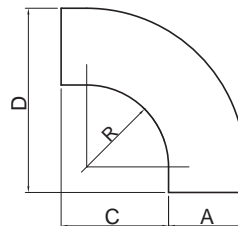

Raio = 320			Raio = 520		
D	C	A	C	D	
620	420	200	620	820	
720	420	300	620	920	
820	420	400	620	1020	
920	420	500	620	1120	
1020	420	600	620	1220	
1120	420	700	620	1320	
1220	420	800	620	1420	
1320	420	900	620	1520	
1420	420	1000	620	1620	
1520	420	1100	620	1720	
1620	420	1200	620	1820	
1920	420	1500	620	2120	

Curva vertical interna curvilíneo | Vertical inside bends

Tabela dimensional

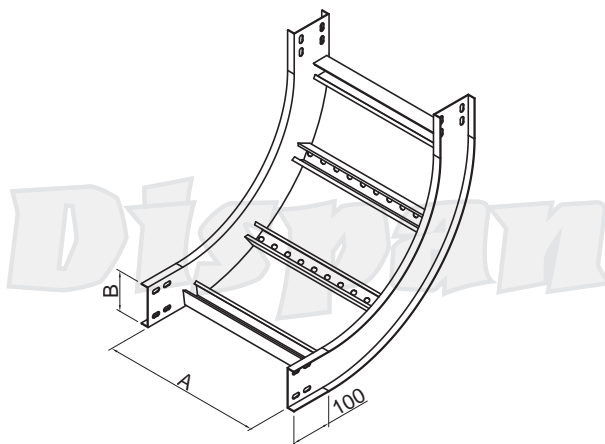

* Cotas em mm.

Curva vertical interna 15° DP812C

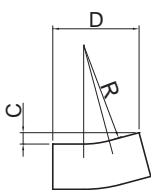

Raio = 320			Raio = 520		
D	C	A	C	D	
279	37	200	44	331	
279	37	300	44	331	
279	37	400	44	331	
279	37	500	44	331	
279	37	600	44	331	
279	37	700	44	331	
279	37	800	44	331	
279	37	900	44	331	
279	37	1000	44	331	
279	37	1100	44	331	
279	37	1200	44	331	
279	37	1500	44	331	

Curva vertical interna 60° DP815C

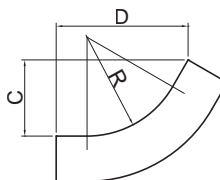

Raio = 320			Raio = 520		
D	C	A	C	D	
427	247	200	347	600	
427	247	300	347	600	
427	247	400	347	600	
427	247	500	347	600	
427	247	600	347	600	
427	247	700	347	600	
427	247	800	347	600	
427	247	900	347	600	
427	247	1000	347	600	
427	247	1100	347	600	
427	247	1200	347	600	
427	247	1500	347	600	

Curva vertical interna 30° DP813C

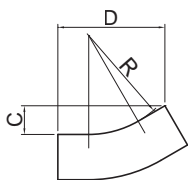

Raio = 320			Raio = 520		
D	C	A	C	D	
347	93	200	120	447	
347	93	300	120	447	
347	93	400	120	447	
347	93	500	120	447	
347	93	600	120	447	
347	93	700	120	447	
347	93	800	120	447	
347	93	900	120	447	
347	93	1000	120	447	
347	93	1100	120	447	
347	93	1200	120	447	
347	93	1500	120	447	

Curva vertical interna 75° DP816C

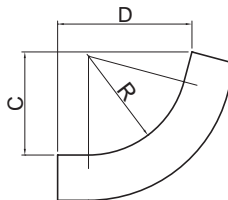

Raio = 320			Raio = 520		
D	C	A	C	D	
435	334	200	482	628	
435	334	300	482	628	
435	334	400	482	628	
435	334	500	482	628	
435	334	600	482	628	
435	334	700	482	628	
435	334	800	482	628	
435	334	900	482	628	
435	334	1000	482	628	
435	334	1100	482	628	
435	334	1200	482	628	
435	334	1500	482	628	

Curva vertical interna 45° DP814C

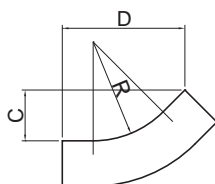

Raio = 320			Raio = 520		
D	C	A	C	D	
397	164	200	223	538	
397	164	300	223	538	
397	164	400	223	538	
397	164	500	223	538	
397	164	600	223	538	
397	164	700	223	538	
397	164	800	223	538	
397	164	900	223	538	
397	164	1000	223	538	
397	164	1100	223	538	
397	164	1200	223	538	
397	164	1500	223	538	

Curva vertical interna 90° DP817C

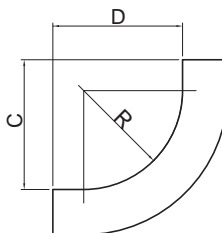

Raio = 320			Raio = 520		
D	C	A	C	D	
420	420	200	620	620	
420	420	300	620	620	
420	420	400	620	620	
420	420	500	620	620	
420	420	600	620	620	
420	420	700	620	620	
420	420	800	620	620	
420	420	900	620	620	
420	420	1000	620	620	
420	420	1100	620	620	
420	420	1200	620	620	
420	420	1500	620	620	

Curva vertical externa curvilíneo | Vertical outside bends

Tabela dimensional

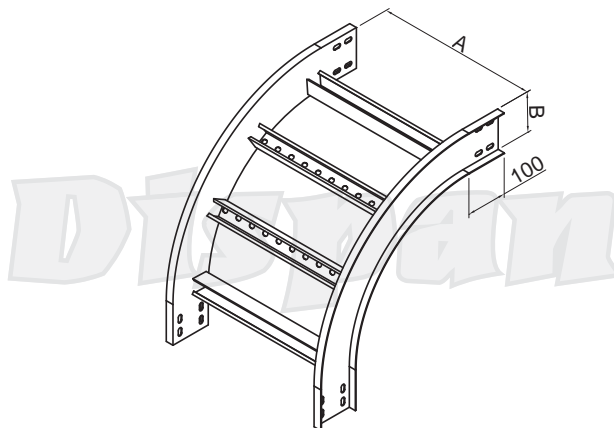

* Cotas em mm.

Curva vertical externa 15° DP818C

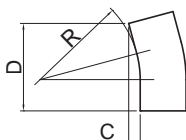

Raio = 320		Raio = 520		
D	C	A	C	D
279	37	200	44	231
279	37	300	44	231
279	37	400	44	231
279	37	500	44	231
279	37	600	44	231
279	37	700	44	231
279	37	800	44	231
279	37	900	44	231
279	37	1000	44	231
279	37	1100	44	231
279	37	1200	44	231
279	37	1500	44	231

Curva vertical externa 60° DP821C

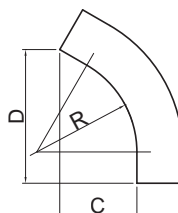

Raio = 320		Raio = 520		
D	C	A	C	D
427	247	200	347	600
427	247	300	347	600
427	247	400	347	600
427	247	500	347	600
427	247	600	347	600
427	247	700	347	600
427	247	800	347	600
427	247	900	347	600
427	247	1000	347	600
427	247	1100	347	600
427	247	1200	347	600
427	247	1500	347	600

Curva vertical externa 30° DP819C

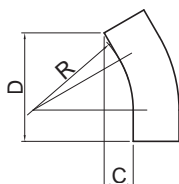

Raio = 320		Raio = 520		
D	C	A	C	D
347	93	200	120	447
347	93	300	120	447
347	93	400	120	447
347	93	500	120	447
347	93	600	120	447
347	93	700	120	447
347	93	800	120	447
347	93	900	120	447
347	93	1000	120	447
347	93	1100	120	447
347	93	1200	120	447
347	93	1500	120	447

Curva vertical externa 75° DP822C

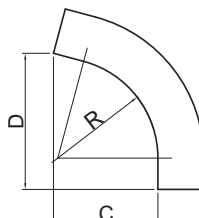

Raio = 320		Raio = 520		
D	C	A	C	D
435	334	200	482	628
435	334	300	482	628
435	334	400	482	628
435	334	500	482	628
435	334	600	482	628
435	334	700	482	628
435	334	800	482	628
435	334	900	482	628
435	334	1000	482	628
435	334	1100	482	628
435	334	1200	482	628
435	334	1500	482	628

Curva vertical externa 45° DP820C

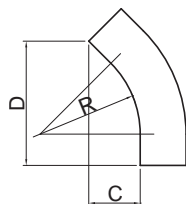

Raio = 320		Raio = 520		
D	C	A	C	D
397	164	200	223	538
397	164	300	223	538
397	164	400	223	538
397	164	500	223	538
397	164	600	223	538
397	164	700	223	538
397	164	800	223	538
397	164	900	223	538
397	164	1000	223	538
397	164	1100	223	538
397	164	1200	223	538
397	164	1500	223	538

Curva vertical externa 90° DP823C

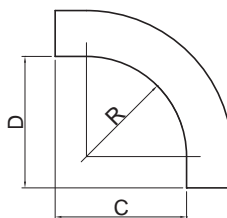

Raio = 320		Raio = 520		
D	C	A	C	D
420	420	200	620	620
420	420	300	620	620
420	420	400	620	620
420	420	500	620	620
420	420	600	620	620
420	420	700	620	620
420	420	800	620	620
420	420	900	620	620
420	420	1000	620	620
420	420	1100	620	620
420	420	1200	620	620
420	420	1500	620	620

Curva de inversão 90° curvilíneo | Transitional bends

DP: 824C



Tabela dimensional

Raio = 320		Raio = 520		
D	C	A	C	D
420	420	200	620	620
420	420	300	620	620
420	420	400	620	620
420	420	500	620	620
420	420	600	620	620
420	420	700	620	620
420	420	800	620	620
420	420	900	620	620
420	420	1000	620	620
420	420	1100	620	620
420	420	1200	620	620
420	420	1500	620	620

Exemplo de montagem da curva de inversão 90°

Typical applications

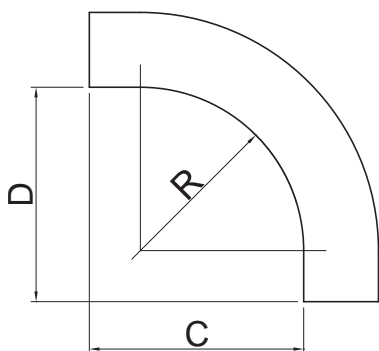
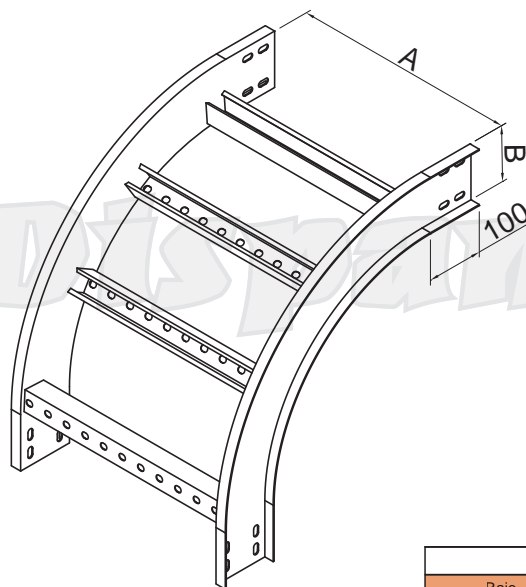
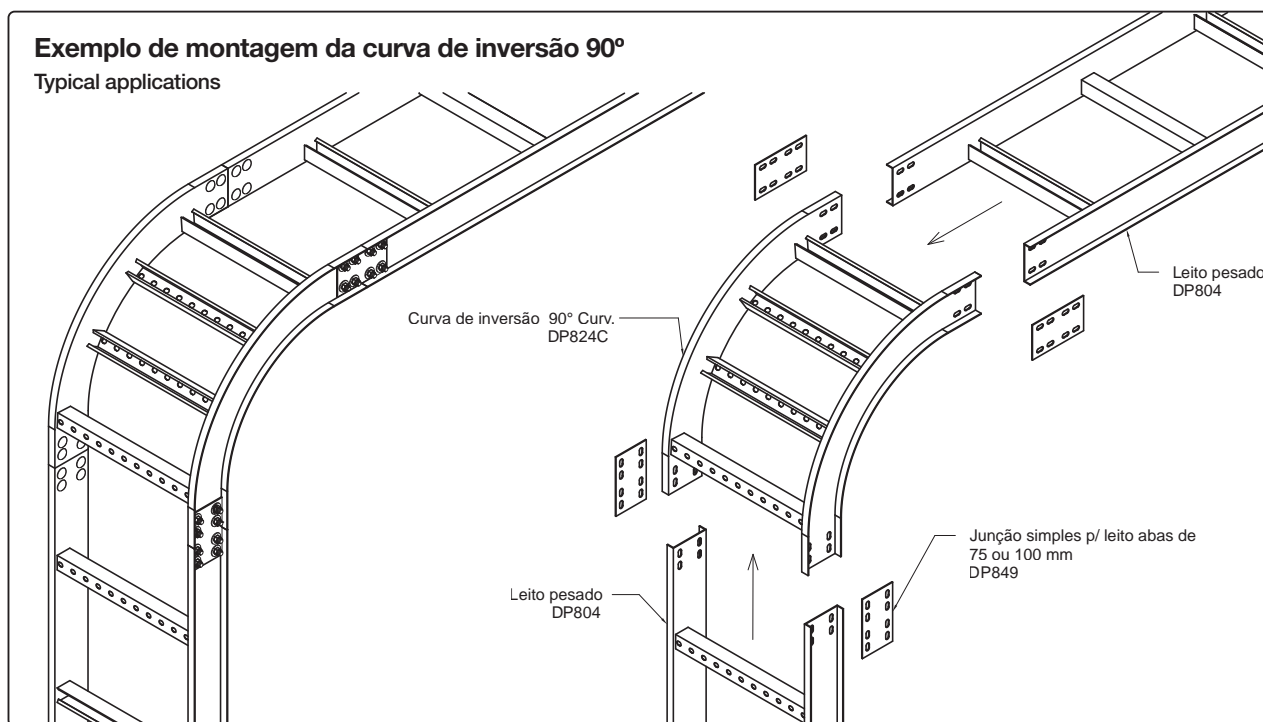

Junção à direita 90° curvilíneo | Right - hand y - branch

DP: 825C

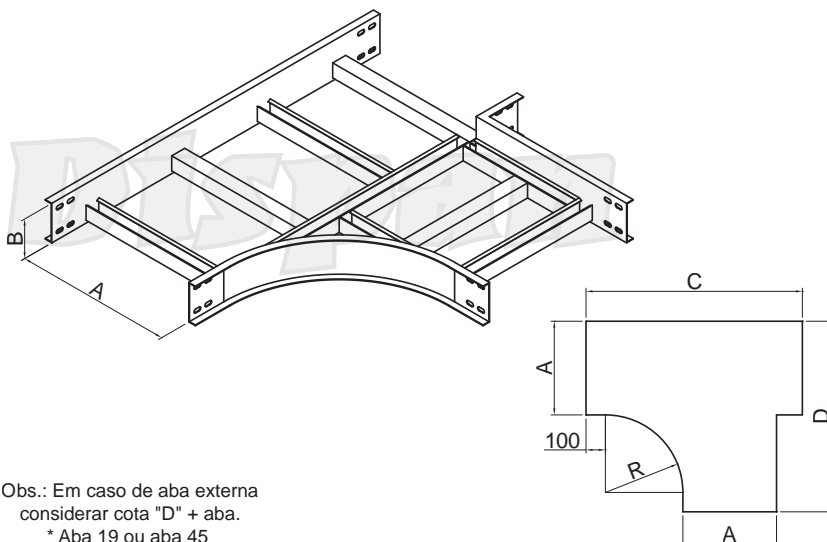

Obs.: Em caso de aba externa considerar cota "D" + aba.
* Aba 19 ou aba 45

Tabela dimensional				
Raio = 320			Raio = 520	
D	C	A	D	C
620	752	200	820	1035
720	852	300	920	1135
820	952	400	1020	1235
920	1052	500	1120	1335
1020	1152	600	1220	1435
1120	1252	700	1320	1535
1220	1352	800	1420	1635
1320	1452	900	1520	1735
1420	1552	1000	1620	1835
1520	1652	1100	1720	1935
1620	1752	1200	1820	2035
1920	2052	1500	2120	2335

Junção à esquerda 90° curvilíneo | Left - hand y - branch

DP: 827C

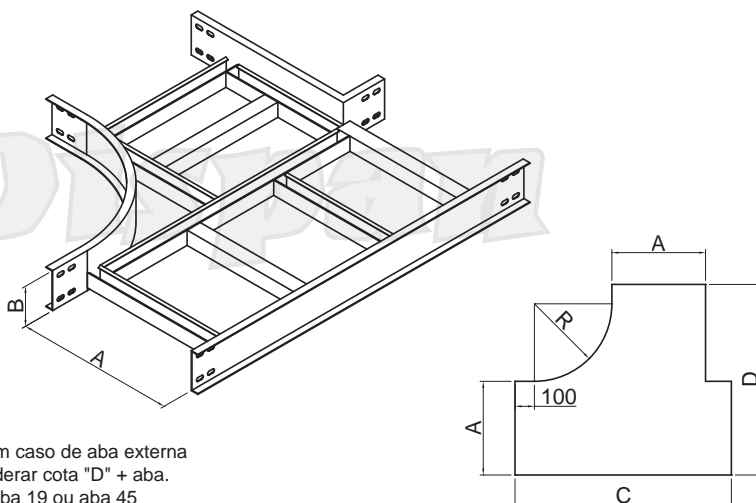

Obs.: Em caso de aba externa considerar cota "D" + aba.
* Aba 19 ou aba 45

Tabela dimensional				
Raio = 320			Raio = 520	
D	C	A	D	C
620	752	200	820	1035
720	852	300	920	1135
820	952	400	1020	1235
920	1052	500	1120	1335
1020	1152	600	1220	1435
1120	1252	700	1320	1535
1220	1352	800	1420	1635
1320	1452	900	1520	1735
1420	1552	1000	1620	1835
1520	1652	1100	1720	1935
1620	1752	1200	1820	2035
1920	2052	1500	2120	2335

Tê horizontal 90° curvilíneo | Horizontal tee

DP: 829C

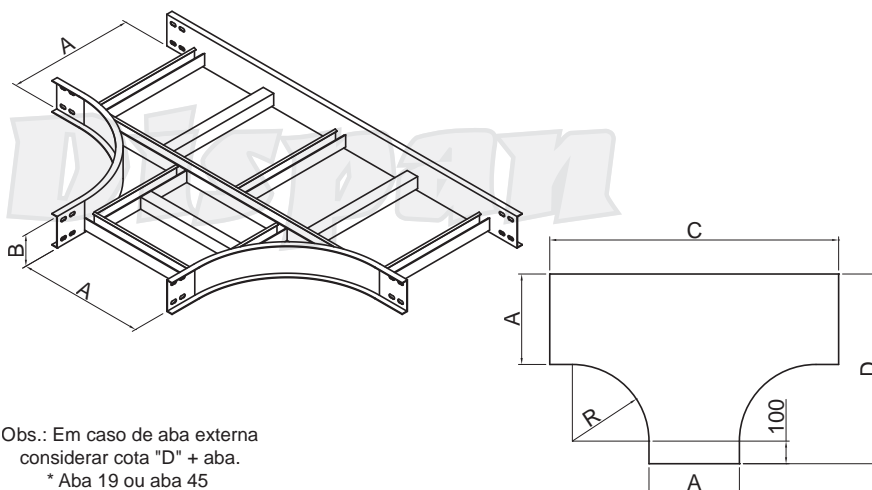

Obs.: Em caso de aba externa considerar cota "D" + aba.
* Aba 19 ou aba 45

Tabela dimensional				
Raio = 320			Raio = 520	
D	C	A	C	D
620	1040	200	1440	820
720	1140	300	1540	920
820	1240	400	1640	1020
920	1340	500	1740	1120
1020	1440	600	1840	1220
1120	1540	700	1940	1320
1220	1640	800	2040	1420
1320	1740	900	2140	1520
1420	1840	1000	2240	1620
1520	1940	1100	2340	1720
1620	2040	1200	2440	1820
1920	2340	1500	2740	2120

Cruzeta c/ uma saída reta 90° curvilíneo | Cross with one straight outlet

DP: 830C



Tabela dimensional				
Raio = 320			Raio = 520	
D	C	A	C	D
752	1040	200	1440	1035
852	1140	300	1540	1135
952	1240	400	1640	1235
1052	1340	500	1740	1335
1152	1440	600	1840	1435
1252	1540	700	1940	1535
1352	1640	800	2040	1635
1452	1740	900	2140	1735
1552	1840	1000	2240	1835
1652	1940	1100	2340	1935
1752	2040	1200	2440	2035
2052	2340	1500	2740	2335

Cruzeta horizontal curvilíneo | Horizontal cross

DP: 831C

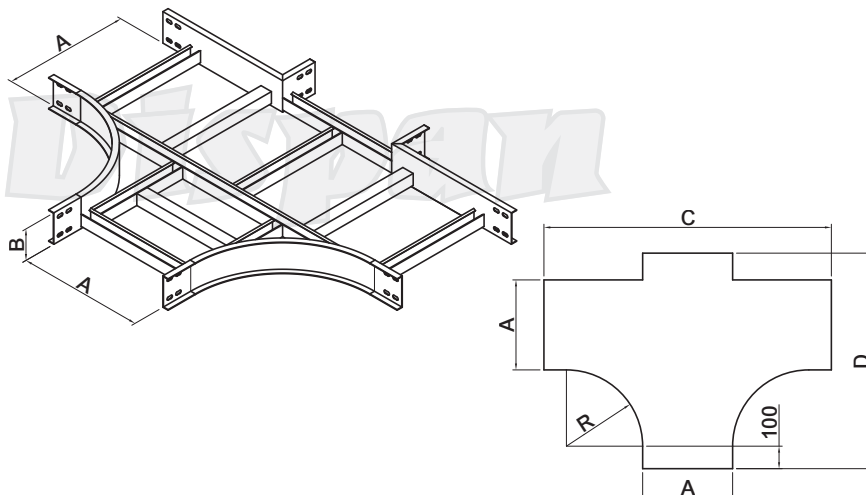

Tabela dimensional		
Raio = 320		Raio = 520
C	A	C
1040	200	1440
1140	300	1540
1240	400	1640
1340	500	1740
1440	600	1840
1540	700	1940
1640	800	2040
1740	900	2140
1840	1000	2240
1940	1100	2340
2040	1200	2440
2340	1500	2740

Presilha guia | Guide saddle

DP: 844

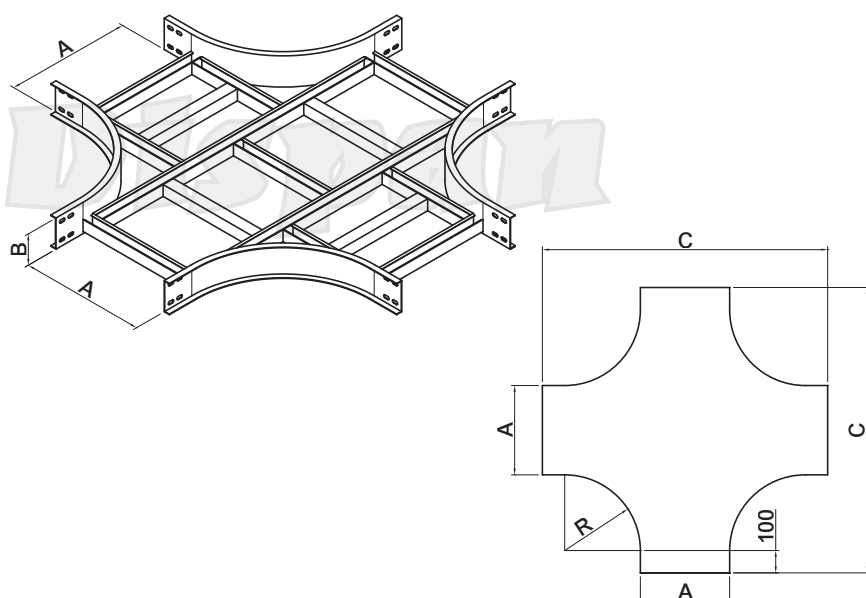
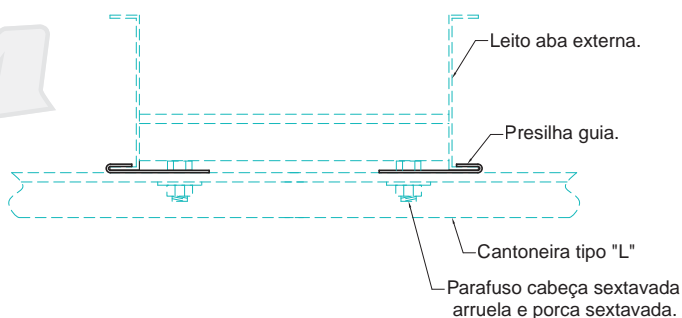
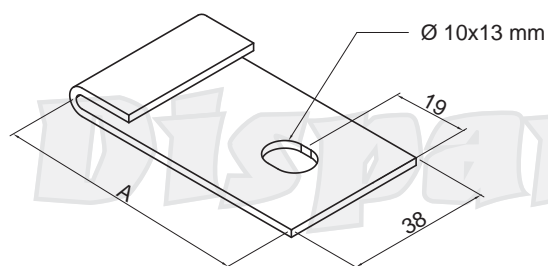

Longarina	A
75 x 19	65
100 x 19	65
100 x 45	90

Proteção para ligação em painel | Box connector

DP: 845

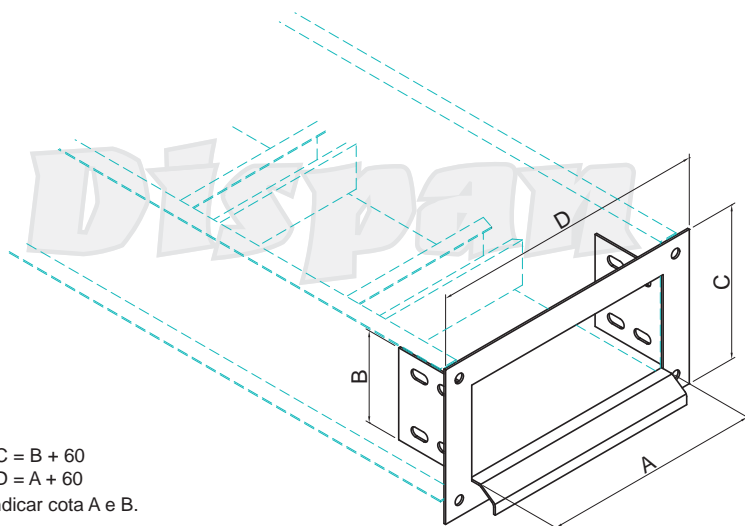

*C = B + 60

*D = A + 60

Indicar cota A e B.

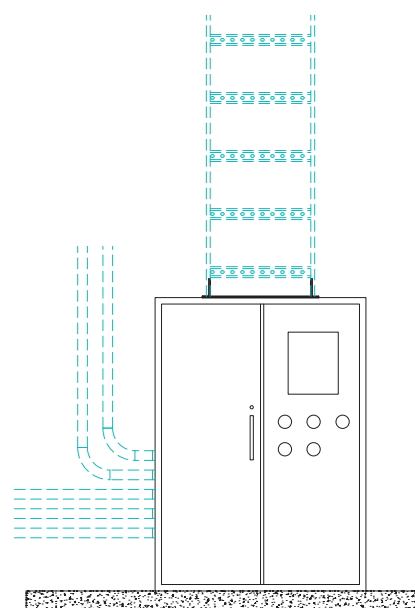

Curva vertical articulada | Adjustable vertical bend

DP: 846

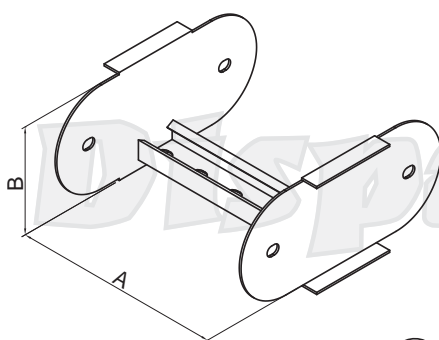

Indicar cota A e B.

*X = Máx. 35°

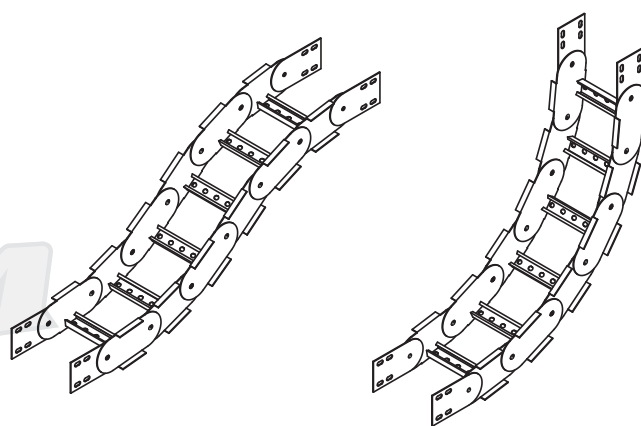

Graus	Número de gomos por raio						
	15°	25°	30°	45°	60°	75°	90°
Raio 320	1	1	2	2	2	3	4
Raio 520	1	1	2	3	4	5	6

Terminal liso para leito | End plate

DP: 846-1

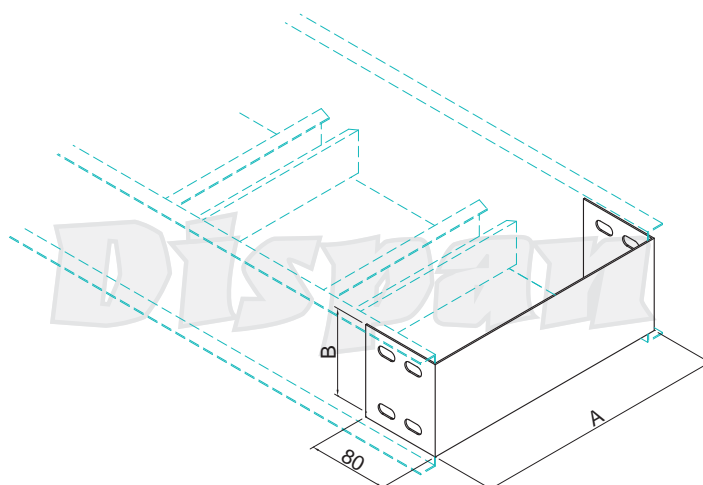

Indicar cota A e B.

Esquema de montagem p/ junção simples

Typical applications

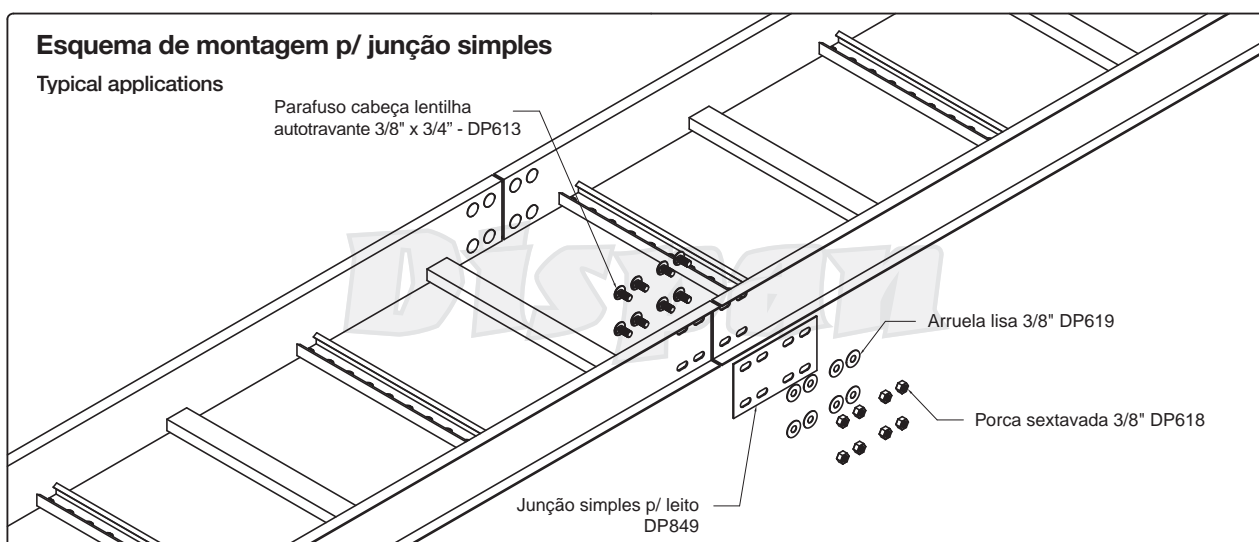

Junção simples para aba de 60 mm | Single splice splice

DP: 847

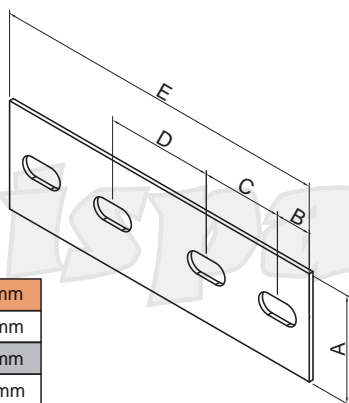

Aba 60 mm
A = 50 mm
B = 19 mm
C = 38 mm
D = 46 mm
E = 160 mm

Obs.: Indicado Parafuso lenticla com porca sextavada e arruela lisa de 3/8" x 3/4".

Junção articulada para aba de 60 mm | Flexible splice

DP: 848

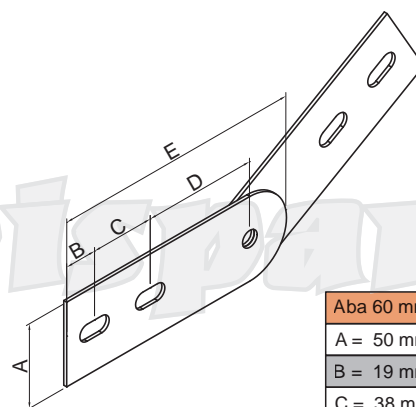

Aba 60 mm
A = 50 mm
B = 19 mm
C = 38 mm
D = 73 mm
E = 160 mm

Obs.: Indicado Parafuso lenticla com porca sextavada e arruela lisa de 3/8" x 3/4".

Junção angular 90° p/ leito aba de 60 mm | Directional change splice plate

DP: 851

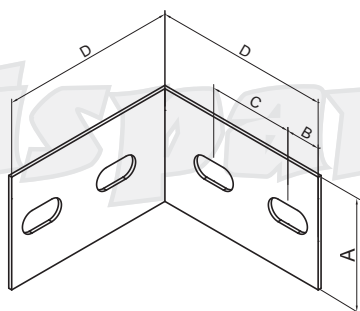

Aba 60 mm
A = 50 mm
B = 19 mm
C = 38 mm
D = 80 mm

Obs.: Indicado Parafuso lentilha com porca sextavada e arruela lisa de 3/8" x 3/4".

Junção simples p/ leito abas 75 ou 100 mm | Single splice plate

DP: 849

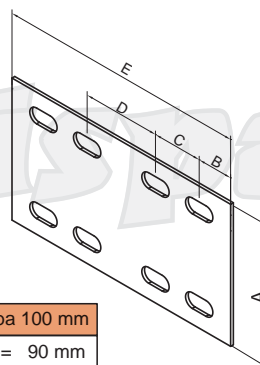

Aba 75 mm	Aba 100 mm
A = 65 mm	A = 90 mm
B = 23 mm	B = 23 mm
C = 32 mm	C = 32 mm
D = 50 mm	D = 50 mm
E = 160 mm	E = 160 mm

Obs.: Indicado Parafuso lentilha com porca sextavada e arruela lisa de 3/8" x 3/4".

Junção articulada p/ leito abas 75 ou 100 mm | Flexible splice

DP: 850

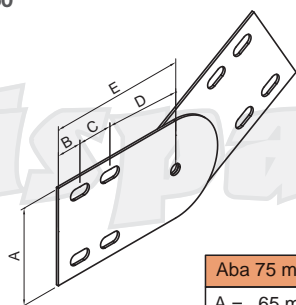

Aba 75 mm	Aba 100 mm
A = 65 mm	A = 90 mm
B = 23 mm	B = 23 mm
C = 32 mm	C = 32 mm
D = 70 mm	D = 70 mm
E = 125 mm	E = 125 mm

Obs.: Indicado Parafuso lentilha com porca sextavada e arruela lisa de 3/8" x 3/4".

Junção angular 90° p/ leito abas 75 ou 100 mm | Directional change splice plate

DP: 852

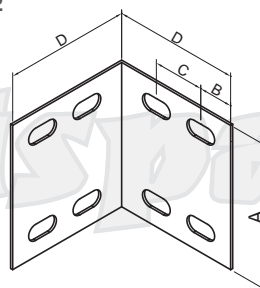

Aba 75 mm	Aba 100 mm
A = 65 mm	A = 90 mm
B = 23 mm	B = 23 mm
C = 32 mm	C = 32 mm
D = 80 mm	D = 80 mm

Obs.: Indicado Parafuso lentilha com porca sextavada e arruela lisa de 3/8" x 3/4".

Tampa de encaixe p/ leito | Cover plate

DP: 853

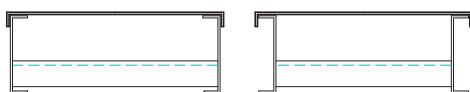
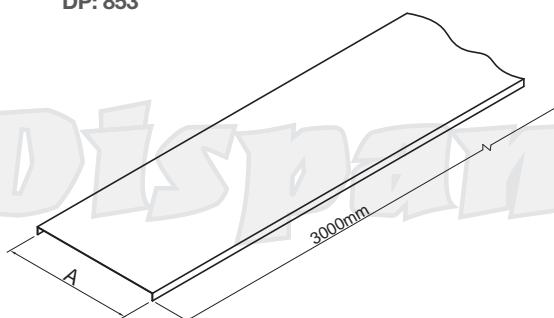

Tampa de pressão p/ leito | Pressure cover

DP: 853-P

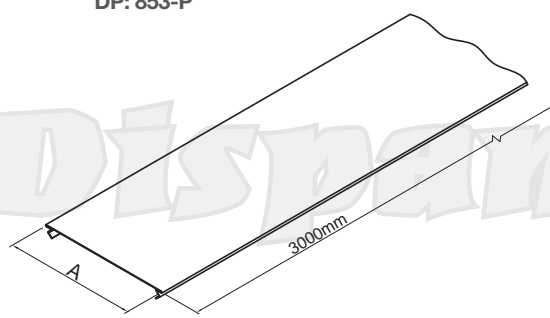

Obs.: Somente para leito aba interna.

Tampa de encaixe c/ cantoneira p/ leito | Insert cover with corner plate

DP: 853-C

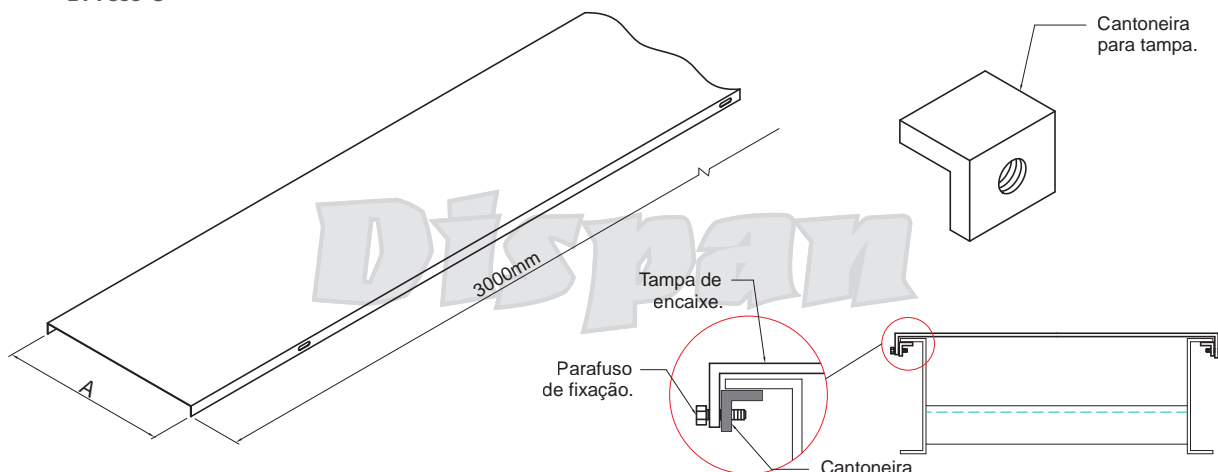

Obs.: As cantoneiras de fixação já acompanham a tampa.

Tampa 2 águas de encaixe c/ cantoneira p/ leito | Angular cover with corner plate

DP: 853-C2A

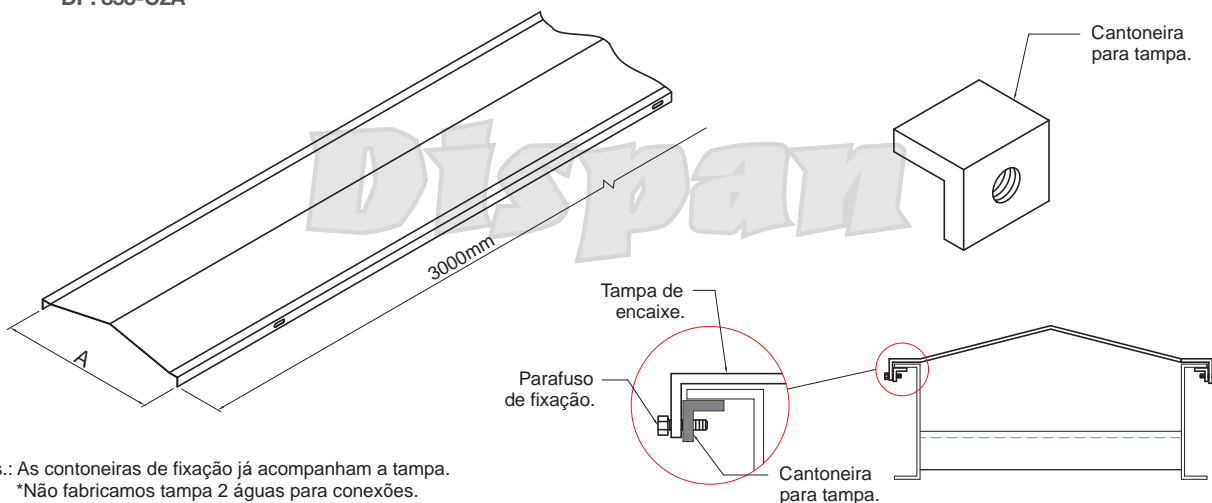

Obs.: As cantoneiras de fixação já acompanham a tampa.
*Não fabricamos tampa 2 águas para conexões.

Tampa 2 águas de encaixe p/ leito

Angular cover

DP: 853-2A

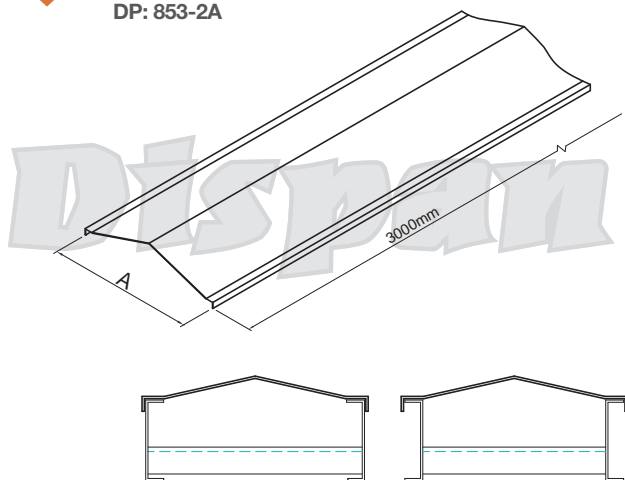

Obs.: Não fabricamos tampa 2 águas para conexões, vide DP859.

Tampa de encaixe c/ fecho rápido p/ leito | Insert cover with fast lock

DP: 853-FR

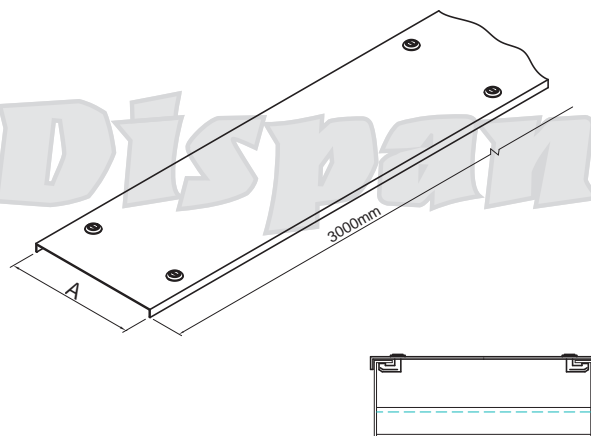

Obs.: Somente para leitos com aba interna.

Septo divisor para leito | Cable tray divider

DP: 854

Descrição do Leito	A
Leito Leve DP800	37
Leito Semipesado DP802	47
Leito Semipesado DP803	72
Leito Semipesado DP804	47
Leito Super Pesado DP805	47

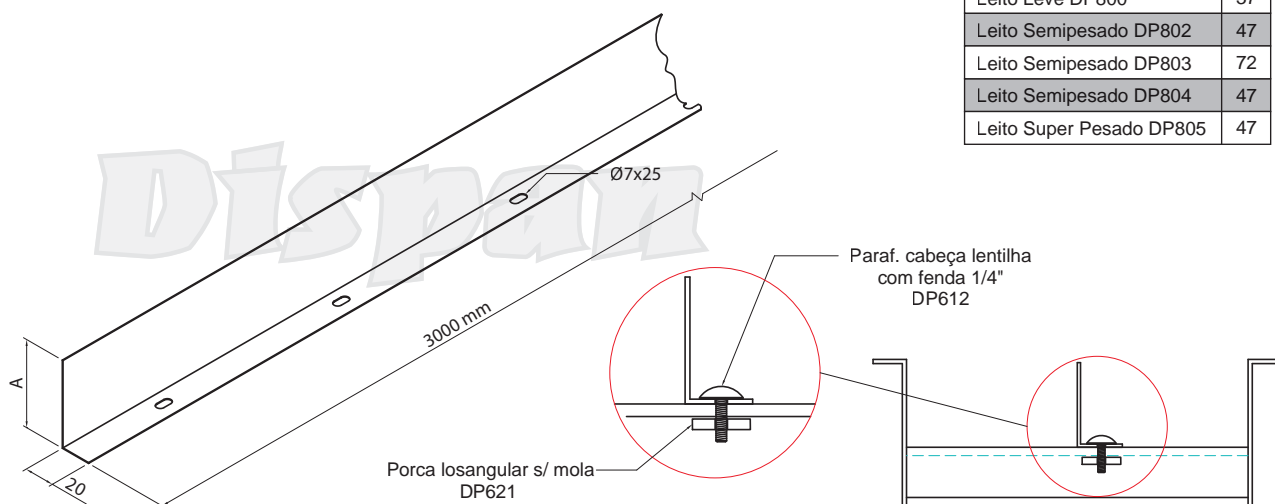

Presilha p/ tampa de encaixe | Cover plate beam clamp

DP: 855

Longarina	A	B
60 x 19	65	25
75 x 19	80	25
100 x 19	105	25
100 x 45	105	51

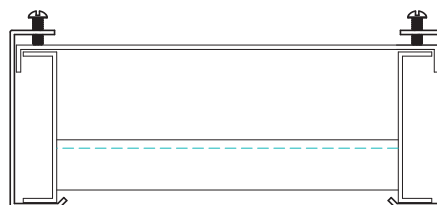
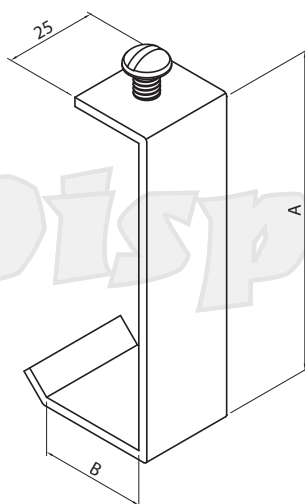

Suporte simples para leito | Single hanger clip

DP: 856

Longarina	A	B
60 x 19	57	22
75 x 19	72	22
100 x 19	97	22
100 x 45	97	48

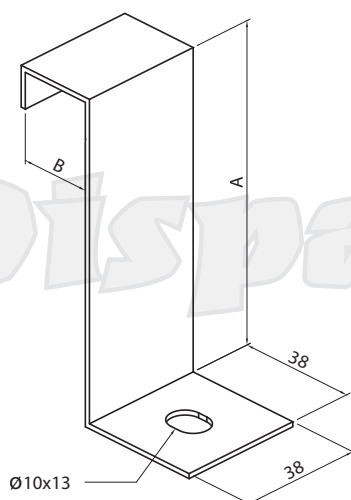

Suporte de suspensão para leito | Side fastening support

DP: 857

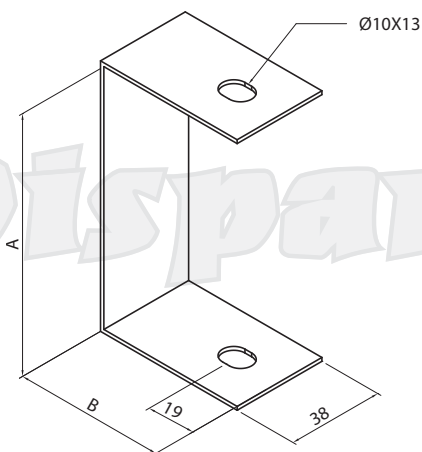

Longarina	A	B
60 x 19	62	51
75 x 19	77	51
100 x 19	102	51
100 x 45	102	72

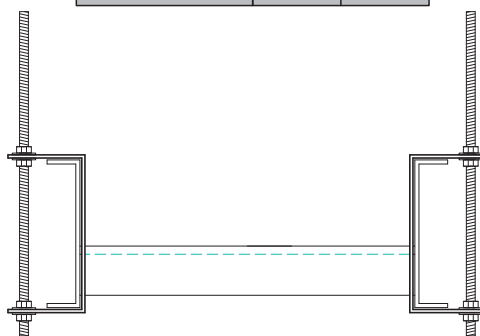

Cinta para fechamento de tampa para leito | Support and belt for cable tray ladder type

DP: 859 C

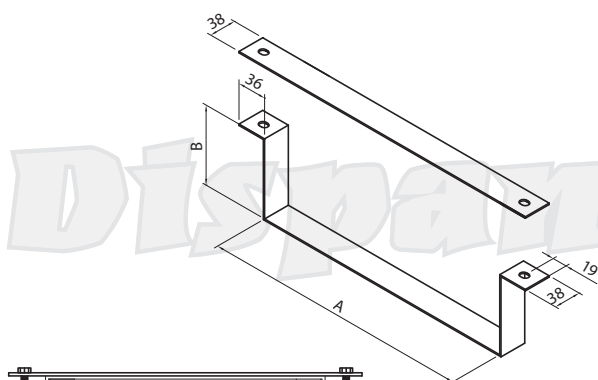

Parafuso cabeça sextavada, arruela lisa e porca sextavada 3/8" x 3/4"
DP's 614, 618 e 619

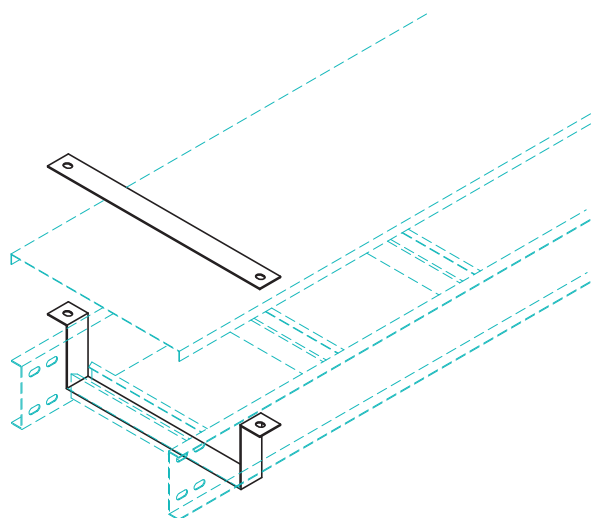

Parafuso cabeça lenticla
c/ fenda | "Lentil" - type head screw

DP: 612

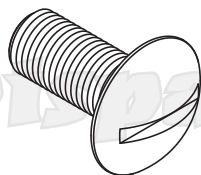

Rosca	Comprimento
1/4"	1/2"
1/4"	5/8"
1/4"	3/4"
5/16"	3/4"
3/8"	3/4"

Parafuso cabeça lenticla
autotravante | "Lentil" - type head screw

DP: 613

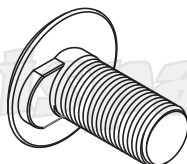

Rosca	Comprimento
1/4"	1/2"
1/4"	5/8"
1/4"	3/4"
5/16"	3/4"
3/8"	3/4"

Parafuso cabeça sextavada
Hex screw

DP: 614

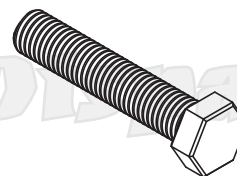

Rosca	Comprimento
1/4"	1/2"
	3/4"
5/16"	1"
	1.1/2"
3/8"	2"
	2.1/2"
	3"

Porca sextavada | Hex nut

DP: 618

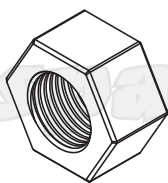

Rosca
1/4"
5/16"
3/8"
1/2"

Arruela lisa | Plain washer

DP: 619



Rosca
1/4"
5/16"
3/8"
1/2"

**Porca losangular s/mola
lozengular nut**

DP: 621

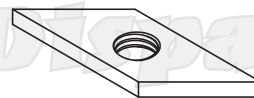

Rosca	Carga máx. em Kg.
1/4"	120 Kg
5/16"	210 Kg
3/8"	450 Kg
1/2"	500 Kg

**Porca losangular c/mola
lozengular nut with spring**

DP: 622

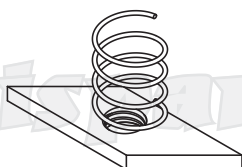

Rosca	Carga máx. em Kg.
1/4"	120 Kg
5/16"	210 Kg
3/8"	450 Kg
1/2"	500 Kg

**Vergalhão rosca total
Continuous threaded rod**

DP: 608



Tabela de carga.	
Diâmetros de vergalhão	Carga máxima
Vergalhão 1/4"	Kg _450_
Vergalhão 5/16"	Kg _600_
Vergalhão 3/8"	Kg _920_
Vergalhão 1/2"	Kg _1250_

**Prolongador p/ vergalhão
Hanger rod extention**

DP: 610

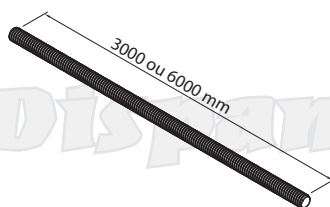

Tabela de carga.	
Diâmetros de prolongador	Carga máxima
Prolongador 1/4"	Kg _450_
Prolongador 5/16"	Kg _600_
Prolongador 3/8"	Kg _920_
Prolongador 1/2"	Kg _1250_

Fixação de leito aba interna com grapa fixa 3/8"

Typical application of the single beam clamp

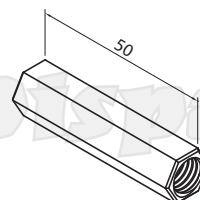
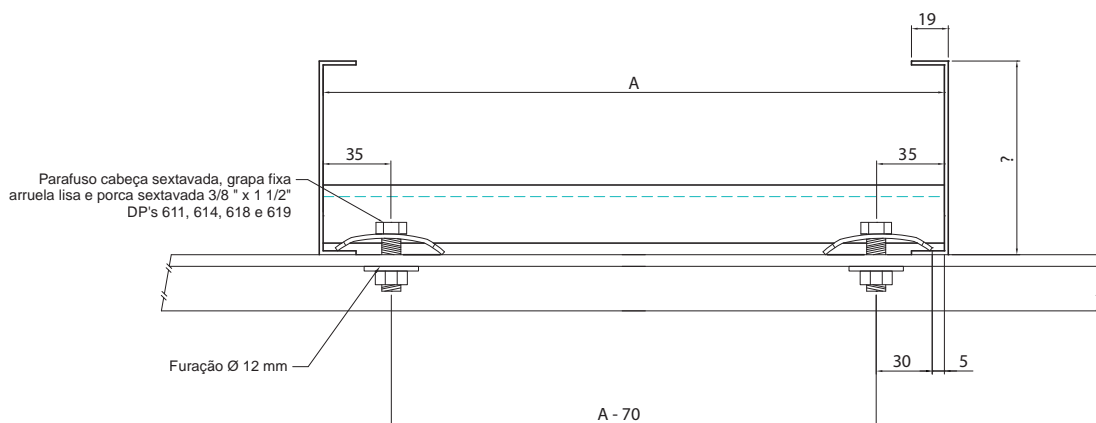

Fixação de leito aba externa com grapa fixa 3/8"

Typical applications of the single beam clamp

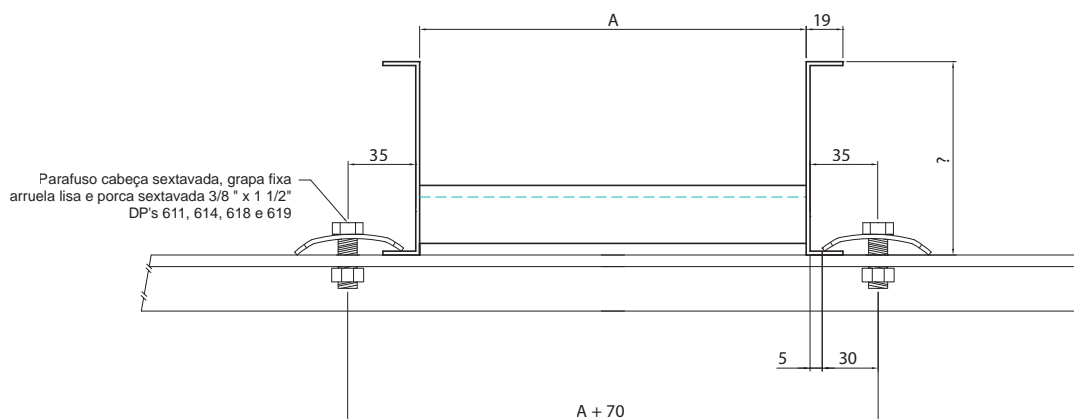

Grapa fixa 3/8" | Single beam clamp

DP: 611

Mata junta p/ tampa de leito

Closing to anglo cover | DP: 859

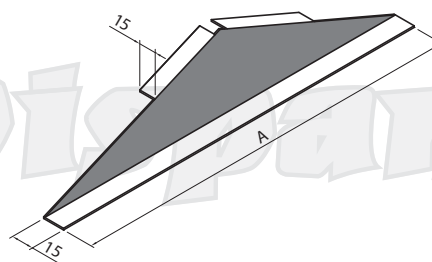
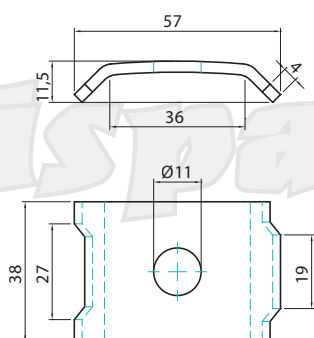

Obs.: As mata juntas são necessárias, todas as vezes que houver um encontro de conexões e trechos retos de leitos utilizando tampa 2 águas.

Esquema de montagem para mata junta para leito

Typical applications of the closing to anglo cover

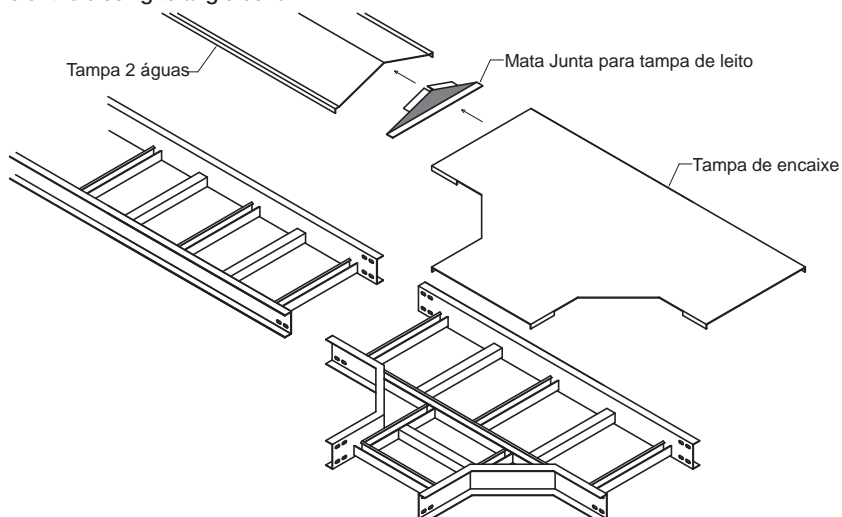

Carga uniformemente distribuída em mão francesa

Uniform ly distribuid loads on bracket

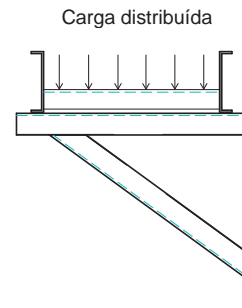
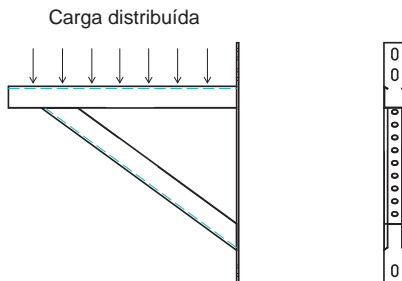
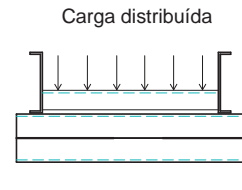
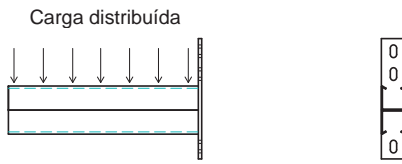

Mão francesa dupla | Double bracket

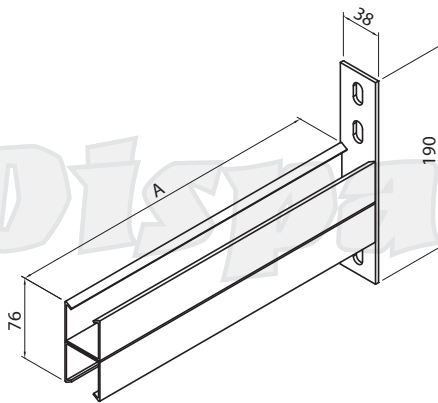

Referência: DP 747	
Mão francesa dupla comercial.	
Tabela de cargas.	
A mm	Carga máxima Kg.
100	180
150	180
200	150
250	150
300	100
400	70
500	60
600	50
700	40
800	35
900	35
1000	30

Referência: DP 747 - I	
Mão francesa dupla industrial.	
Tabela de cargas.	
A mm	Carga máxima Kg.
100	350
150	350
200	350
250	350
300	310
400	270
500	240
600	200
700	170
800	140
900	100
1000	70

Indicar cota A.

Mão francesa reforçada | Reinforced bracket

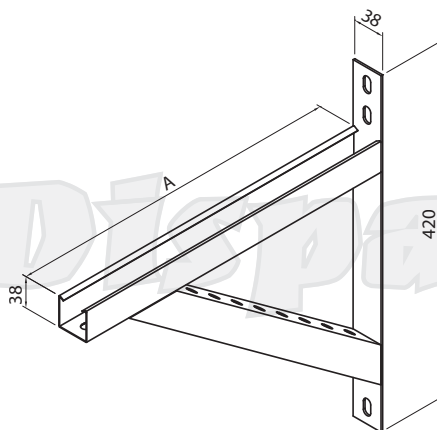

Referência: DP 748	
Mão francesa reforçada comercial.	
Tabela de cargas.	
A mm	Carga Máxima Kg.
100	380
150	380
200	380
250	380
300	350
400	350
500	320
600	320
700	270
800	240
900	200
1000	170
1200	150

Referência: DP 748 - I	
Mão francesa reforçada industrial.	
Tabela de cargas.	
A mm	Carga Máxima Kg.
100	450
150	450
200	450
250	400
300	400
400	400
500	400
600	380
700	380
800	380
900	350
1000	350
1200	330

Indicar cota A

Suporte de fixação para leito
Side fastening support

DP: 858

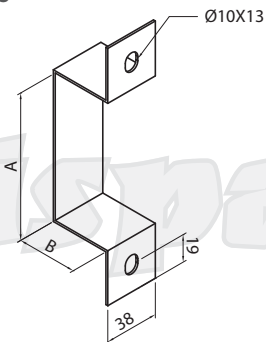

Longarina	A	B
60 x 19	62	16
75 x 19	77	16
100 x 19	102	16
100 x 45	102	42

Gotejador para leito
Cable drop out

DP: 861

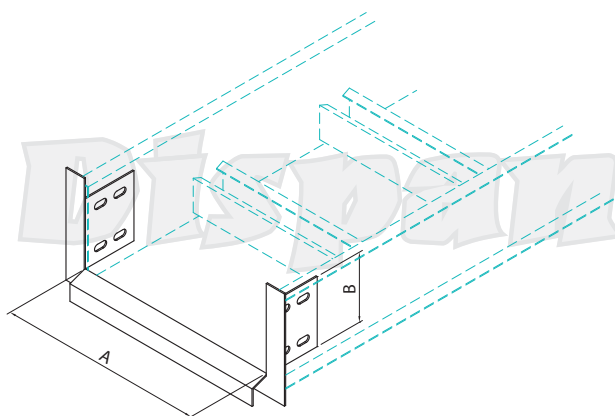

Indicar cota A e B.

Junção horizontal articulada para leito | Horizontal articulated junction

DP: 860

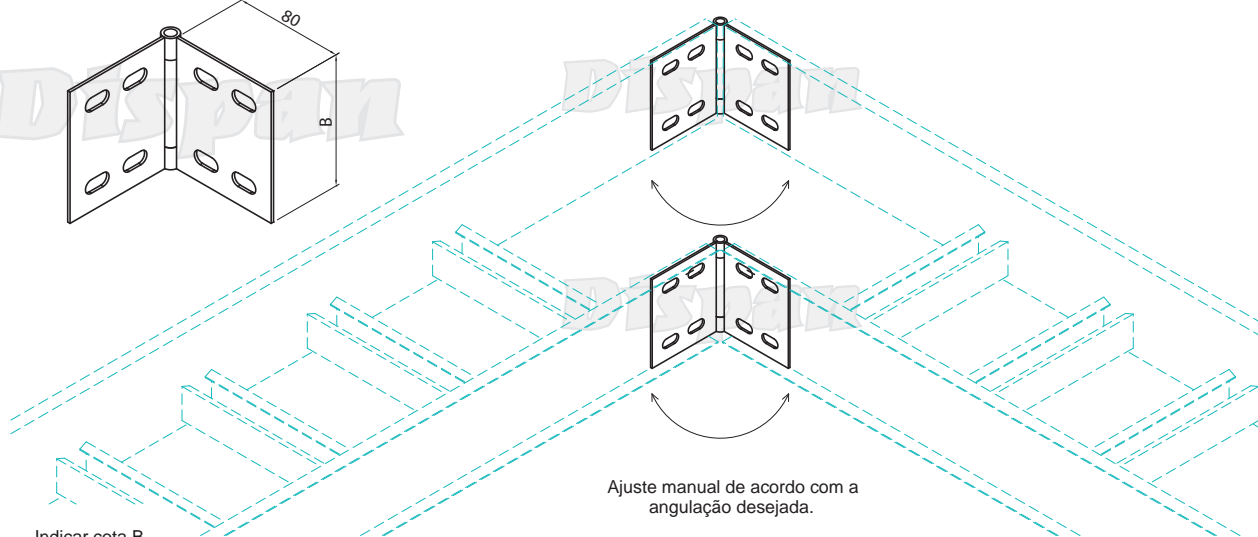
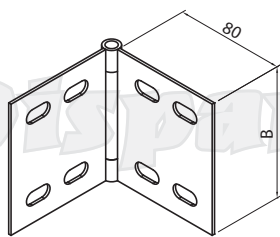

Indicar cota B.

Ajuste manual de acordo com a angulação desejada.

Junção vertical 45° para leito | Vertical junction 45°

DP: 862

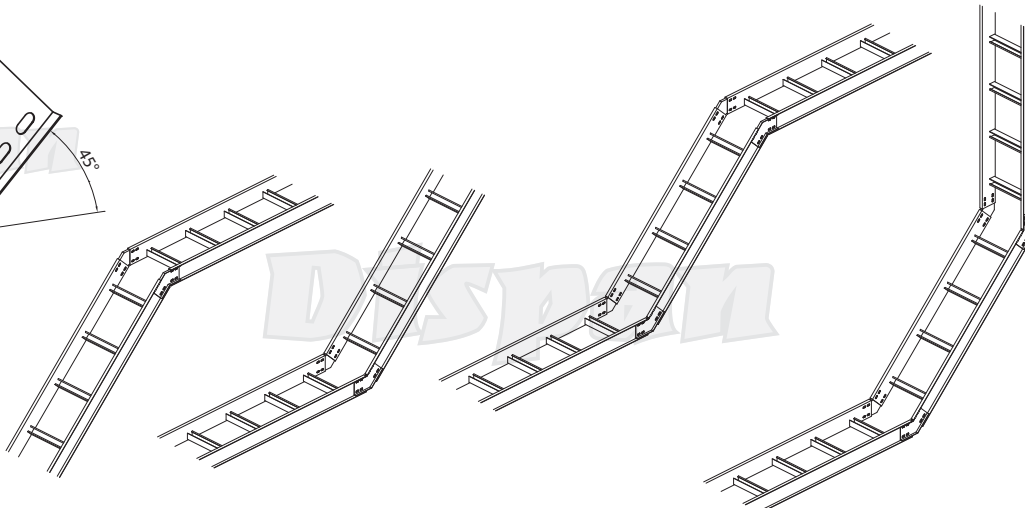
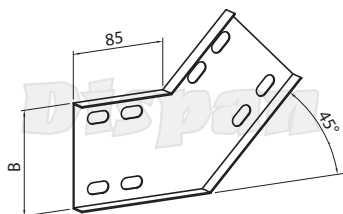

Eletrocalhas

Cable trays

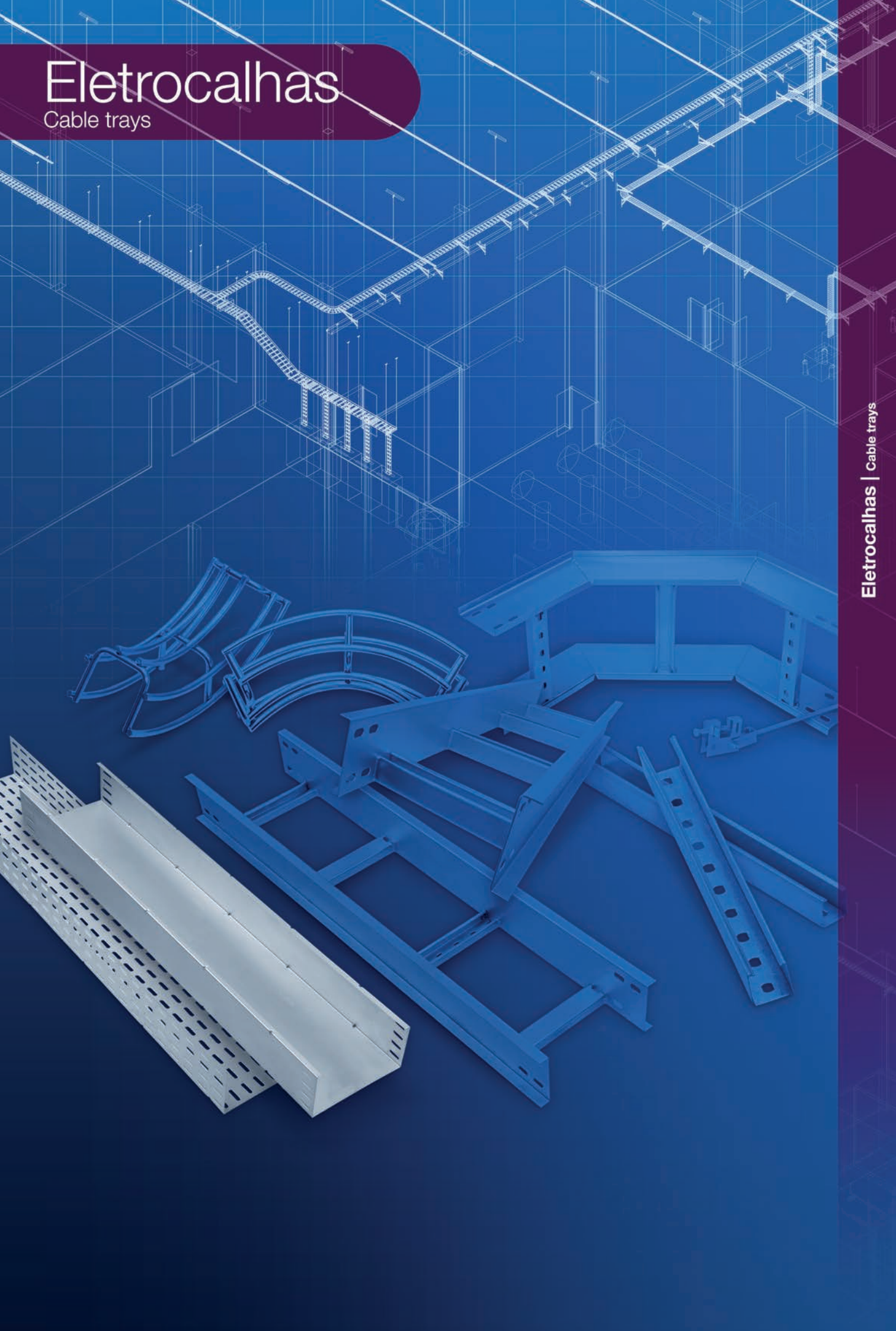

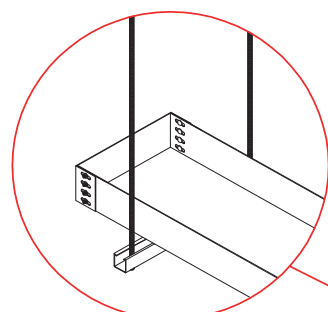

Suportação com perfilado de 38 x 38 perfurado DP 502.

Profiled support of 38 x 38 perforated DP 502

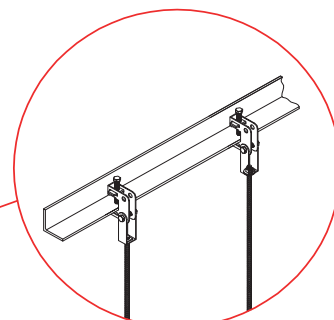

Suportação com grampo "C" e balancim DP's 538 e 540.
Support with staple "C" and balance beam DP's 538 and 540

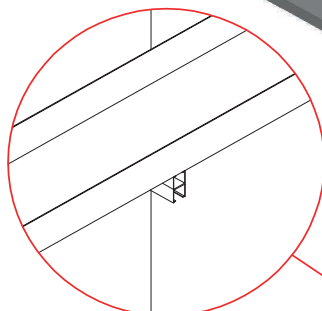

Suportação com mão francesa dupla DP747.
Double bracket support DP747

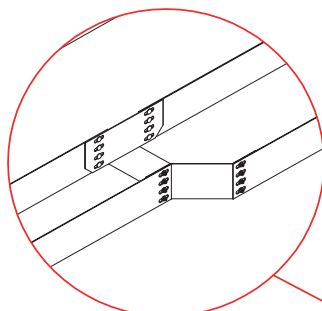

Redução à direita DP731.
Right reduction DP731

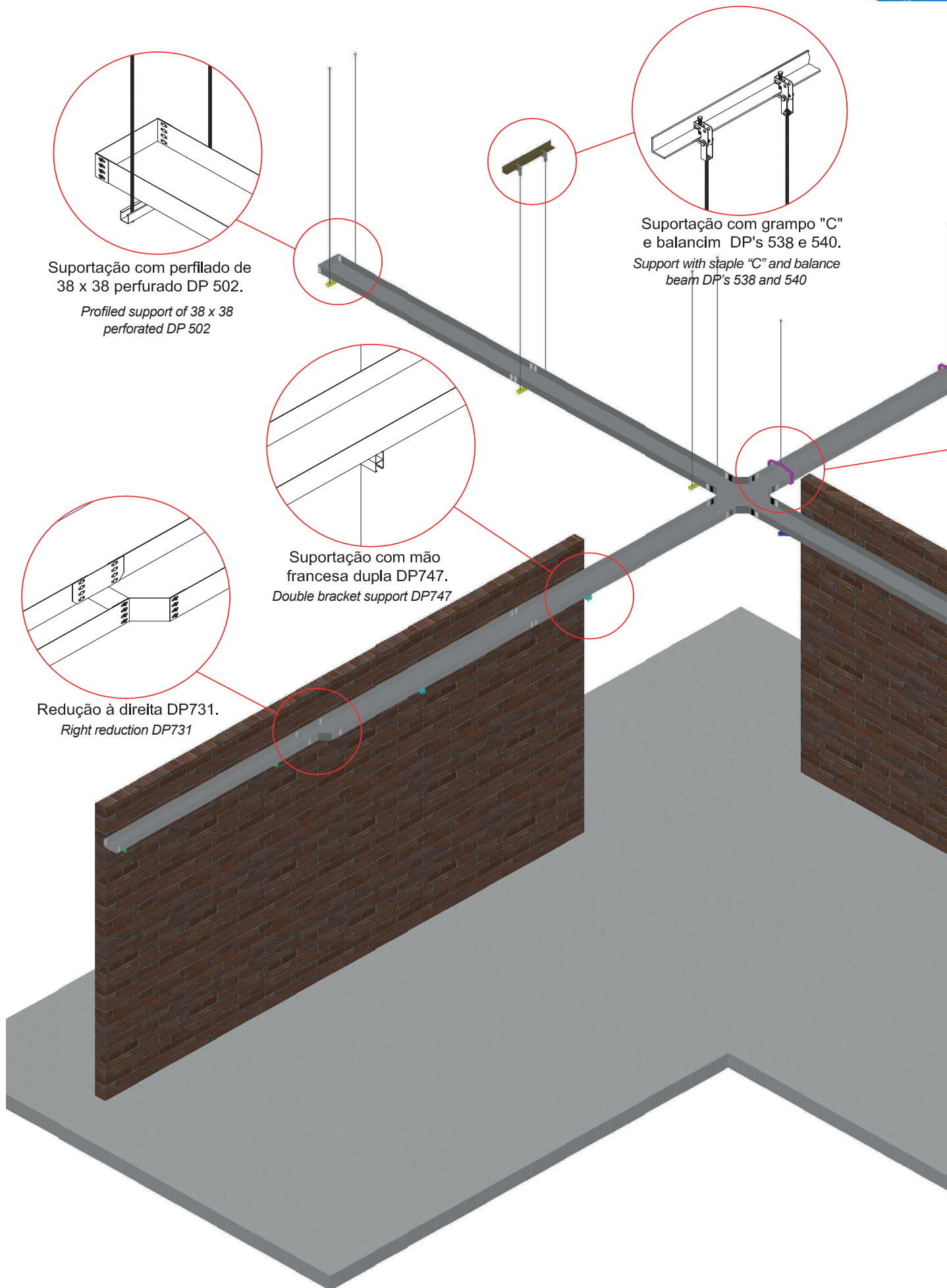

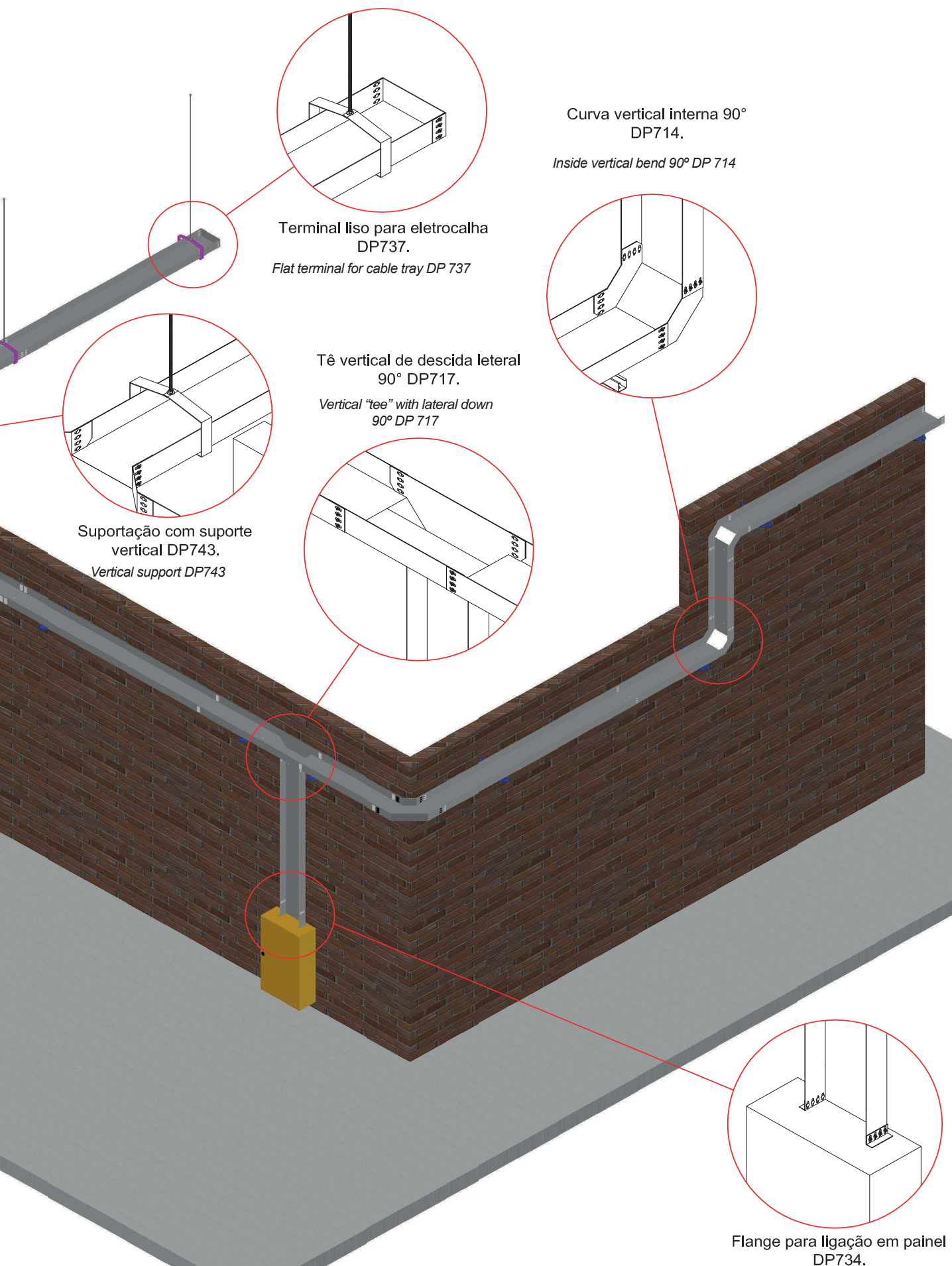

Curva vertical interna 90°
DP714.

Inside vertical bend 90° DP 714

Terminal liso para eletrocalha
DP737.

Flat terminal for cable tray DP 737

Tê vertical de descida lateral
90° DP717.

*Vertical "tee" with lateral down
90° DP 717*

Suportação com suporte
vertical DP743.

Vertical support DP743

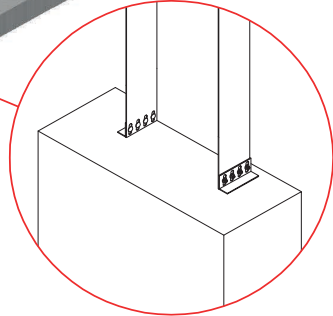

Flange para ligação em painel
DP734.

Flange for connection panel DP734

Exemplo de montagem para eletrocalha

Typical applications

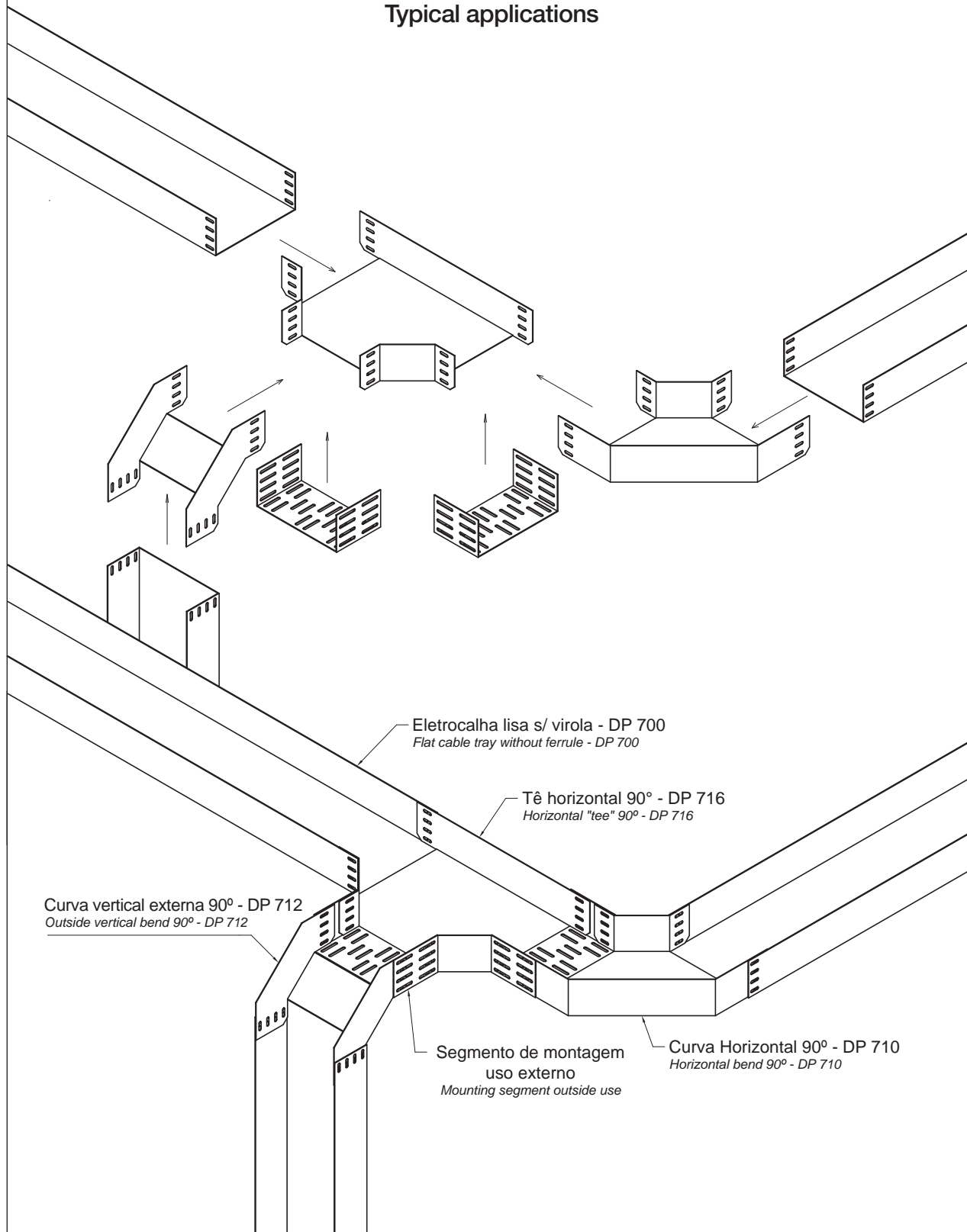

Nota 1

Obs.: Não é necessário usar talas ou emendas entre trecho reto e as conexões.
Obs.: It's not necessary using splints or splices between flat segment and connections.

Nota 2

Obs.: Entre conexões é necessário o uso do segmento de montagem.
Obs.: Between connections, it's necessary using mounting segment.

Como solicitar eletrocalhas

How to specify cable tray channel type.

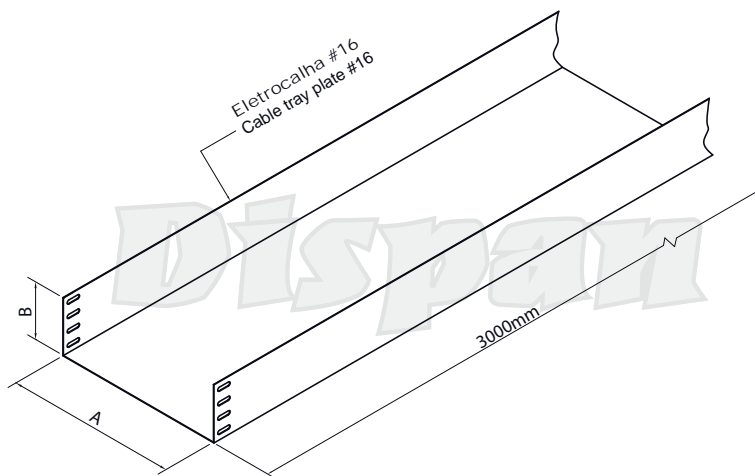

Exemplo

Example

DP700 - AC - GF - 400/100 - 16

Referência do catálogo de produtos com características básicas

Product catalog reference with basic features

Matéria-prima de fabricação

Manufacturing raw material

Acabamento

Finish

Largura / Altura da eletrocalha

Width / height of cable tray

Chapas de construção da eletrocalha

Cable tray construction plate

DP 700 • Eletrocalha lisa sem virola
DP 700 • Flat cable tray without ferrule

Matéria-prima base
Raw material base

AC - Aço carbono
Carbon Steel

AI - Aço inox
Stainless Steel

AL - Alumínio
Aluminum

Acabamento aplicado na matéria-prima em base de aço carbono

Finish applied to the raw material in carbon steel base

GF - Galvanizado à fogo por imersão
Hot dip galvanized

GE - Galvanizado eletrolítico
Electrolytic galvanized

NT - Natural
Natural

PT - Pintado
Painting

Largura:

400 - Largura da eletrocalha desejada (De 50 a 1500 mm).

Width: 400 - width of the wanted cable tray (50 to 1500mm)

Espessuras de chapas:
16 - Chapa de eletrocalha
Plate thickness: 16 - cable tray plate

Descritivo técnico | Technical description

DP 700 • Eletrocalha lisa sem virola, em aço carbono, galvanizado à fogo, largura de 400mm, com aba de 100mm em chapa #16.
DP 700 • Flat single cable tray, carbon steel, hot dip galvanized, width of 400mm, with tab of 100mm in plate #16.

ATENÇÃO!

A DISPAN INDÚSTRIA E COMÉRCIO não recomenda o uso de leito ou eletrocalha como passarela, escada ou apoio para pessoas.
USE APENAS PARA PASSAGEM DE CABOS.

UTILIZE OS EPI'S CONFORME NR-06 E SIGA AS PRÁTICAS DE SEGURANÇA NO TRABALHO, COMO DESCRITO NA NR-10 E NR-35.



Nota

Ocasionalmente podem ocorrer algumas distorções de medidas em nossas peças, por diversos fatores. Por este motivo damos uma tolerância de 5,0 mm entre as medidas mencionadas no catálogo e as peças reais. Os furos oblongos são feitos exatamente para compensação e ajuste de eventuais diferenças.

WARNING!

DISPAN Industry and Trade does not recommend using cable trays or bed ladder as walkway, stair or support for people.
USE ONLY FOR PASSING OF CABLES.

USE THE PPIS AS THE NR-06 AND FOLLOW THE WORK SAFETY PRACTICES AS DESCRIBED IN NR-10 AND NR-35.

Note

Occasionally, it may occur some distortion of measures in our pieces, for several reasons. Because of this, we give a toleration of 5.0 mm between the measures mentioned in this catalog and the real pieces. The slotted holes are made just for clearing and settling of any possible differences.

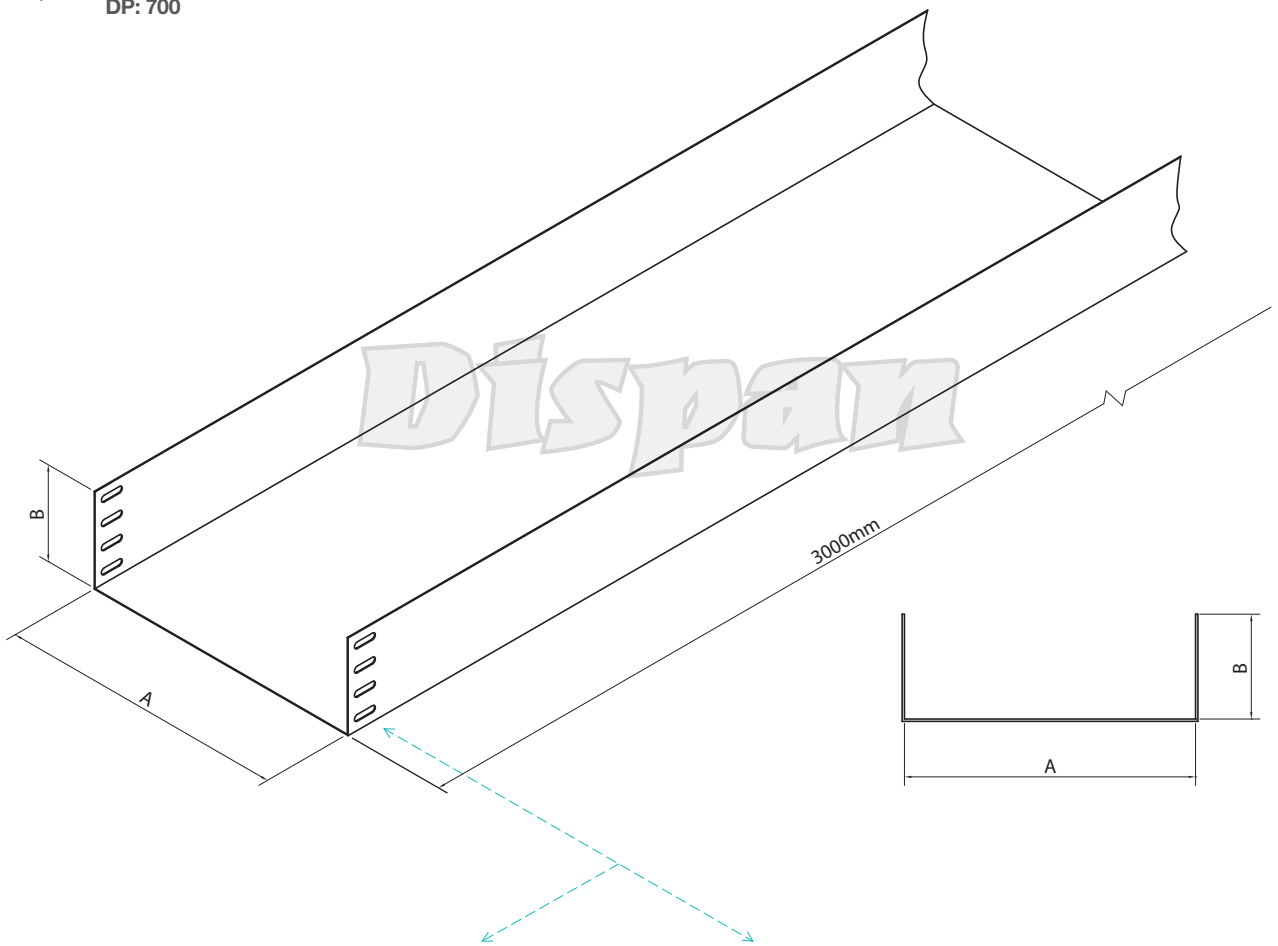

Aba de 50 mm

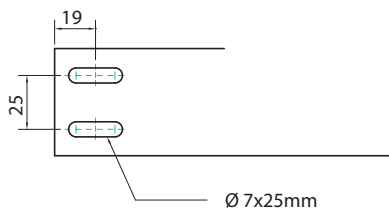

Aba de 75 mm

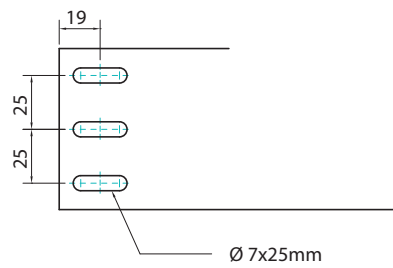

Aba de 100 mm

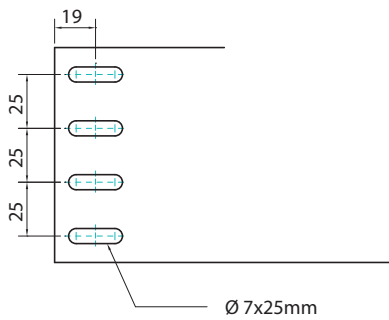

Aba de 150 mm

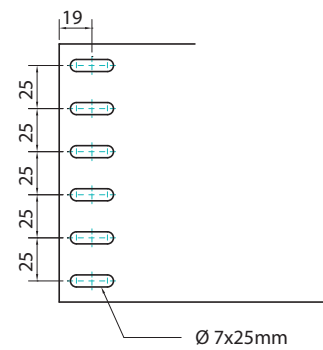

Carga uniformemente distribuída entre suportes • DP: 700

Load Table.

ELETROCALHA LISA S/ VIROLA - REF. DP 700 / ABA 50 mm								
ESPECIFICAÇÕES			Distância entre suportes em mm / Kg. Distance between supports (mm) / loads (Kg).					
Largura mm Width	Peso Kg Wight	Chapa Steel plate	1000 mm	1500 mm	2000 mm	2500 mm	3000 mm	
50	2,9	22	67	48	37	24	16	
50	3,5	20	78	65	42	27	18	
50	4,5	18	102	82	50	32	23	
50	5,6	16	108	88	56	38	28	
50	6,5	14	160	135	114	103	92	
50	9,0	12	180	150	132	117	107	
75	3,4	22	68	55	38	25	17	
75	4,0	20	80	67	44	28	18	
75	5,2	18	102	82	52	33	24	
75	6,5	16	110	90	57	39	29	
75	7,5	14	162	137	115	103	92	
75	10,5	12	182	152	132	117	107	
100	3,9	22	71	60	41	31	21	
100	4,6	20	80	67	45	34	24	
100	6,0	18	102	84	57	47	35	
100	7,5	16	110	91	65	52	40	
100	8,7	14	162	137	116	103	92	
100	12,0	12	182	152	132	117	107	
150	4,8	22	75	64	43	32	23	
150	5,7	20	80	67	46	35	25	
150	7,5	18	102	84	62	49	36	
150	9,5	16	110	91	65	52	40	
150	10,8	14	162	137	116	103	92	
150	15,0	12	182	152	132	117	107	
200	5,8	22	80	65	45	35	26	
200	7,0	20	83	68	50	42	27	
200	9,0	18	102	84	60	47	35	
200	11,5	16	110	91	65	54	42	
200	12,9	14	162	137	116	103	92	
200	18,0	12	182	152	132	117	107	
300	9,5	20	90	74	54	43	32	
300	12	18	105	84	62	47	35	
300	15	16	120	98	74	52	40	
300	17,3	14	162	137	116	103	92	
300	24,0	12	182	152	132	117	107	
400	11,4	20	92	76	57	45	34	
400	15	18	107	84	65	49	39	
400	16	16	142	110	86	60	44	
400	21,6	14	162	137	116	103	92	
400	30,0	12	182	152	132	117	107	

Load Table.

ELETROCALHA LISA S/ VIROLA - REF. DP 700 / ABA 75 mm								
ESPECIFICAÇÕES			Distância entre suportes em mm / Kg. Distance between supports (mm) / loads (Kg).					
Largura mm Width	Peso Kg Wight	Chapa Steel plate	1000 mm	1500 mm	2000 mm	2500 mm	3000 mm	
75	4,3	22	68	54	37	29	20	
75	5,2	20	72	61	46	38	25	
75	6,8	18	84	73	63	42	35	
75	8,1	16	105	88	70	50	42	
75	9,7	14	160	135	120	103	93	
75	13,5	12	182	152	133	120	105	
100	4,8	22	68	54	37	31	20	
100	5,7	20	76	63	46	38	25	
100	7,5	18	88	66	63	42	35	
100	9,5	16	110	90	70	50	42	
100	10,8	14	160	135	120	103	93	
100	15,0	12	182	152	133	120	105	
150	6,0	22	68	54	39	33	22	
150	7,0	20	84	66	52	38	28	
150	9,0	18	94	77	63	42	35	
150	11,5	16	120	98	70	50	42	
150	13,0	14	160	135	120	103	93	
150	18,0	12	182	152	133	120	105	
200	8,0	22	72	60	43	36	24	
200	9,8	20	90	74	55	41	30	
200	10,5	18	100	83	63	44	35	
200	13,5	16	126	101	76	51	42	
200	15,1	14	160	135	120	103	93	
200	21,0	12	182	152	133	120	105	
300	10,5	20	95	80	60	46	35	
300	13,5	18	110	86	65	48	36	
300	17,0	16	131	113	81	66	42	
300	19,4	14	160	135	120	103	93	
300	27,0	12	182	152	133	120	105	
400	16,5	18	120	100	70	59	41	
400	20,5	16	142	116	81	67	42	
400	23,7	14	162	135	120	103	93	
400	33,0	12	182	152	133	120	105	
500	23,5	16	142	116	84	67	43	
500	28,0	14	162	135	120	103	93	
500	39,0	12	182	152	133	120	105	

Aplicação típica Typical application

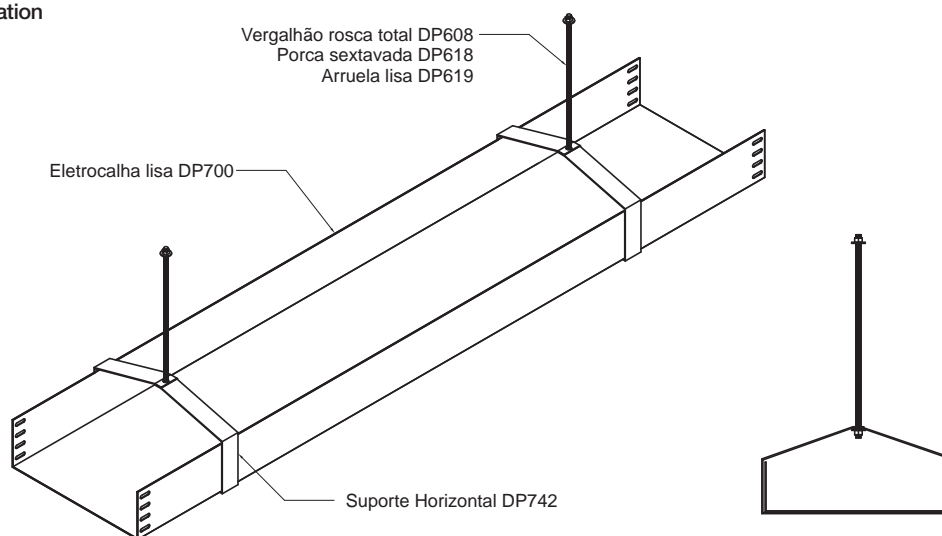

Carga uniformemente distribuída entre suportes • DP: 700

Load Table.

ELETROCALHA LISA S/ VIROLA - REF. DP 700 / ABA 100 mm			Distância entre suportes em mm / Kg. Distance between supports (mm) / loads (Kg).				
ESPECIFICAÇÕES			1000 mm	1500 mm	2000 mm	2500 mm	3000 mm
Largura mm Width	Peso Kg Wight	Chapa Steel plate					
100	7,0	20	83	70	52	38	26
100	9,0	18	94	75	58	43	30
100	11,5	16	125	103	75	53	40
100	13,0	14	160	135	120	110	99
100	18,0	12	180	160	140	124	112
150	8,0	20	86	72	56	41	28
150	11,0	18	96	78	60	45	33
150	13,5	16	130	108	75	57	43
150	15,0	14	160	135	120	110	99
150	21,0	12	180	160	140	124	112
200	9,5	20	90	74	56	44	29
200	12,5	18	106	86	65	51	35
200	15,0	16	130	108	75	57	43
200	17,5	14	160	135	120	110	99
200	24,0	12	180	160	140	124	112
300	12,0	20	102	75	58	47	29
300	15,5	18	112	96	72	56	35
300	19,0	16	131	108	75	57	43
300	21,6	14	160	135	120	110	99
300	30,0	12	180	160	140	124	112
400	14,0	20	102	75	58	47	29
400	18,5	18	121	103	78	63	39
400	22,5	16	140	113	85	68	43
400	25,9	14	170	135	120	110	99
400	36,0	12	180	160	140	124	112
500	21,5	18	130	105	79	67	42
500	26,5	16	152	123	92	81	50
500	30,5	14	170	147	120	110	99
500	42,0	12	180	160	140	124	112
600	24,5	18	140	112	94	76	50
600	30,5	16	158	134	100	91	55
600	35,0	14	170	147	121	110	99
600	48,0	12	180	165	140	124	112
700	27,0	18	140	118	95	82	55
700	34,0	16	155	148	112	92	62
700	39,5	14	170	150	125	110	99
700	54,0	12	185	170	142	125	112
800	38,0	16	160	150	121	100	69
800	44,0	14	170	165	130	110	99
800	60,0	12	190	170	145	125	112

Load Table.

ELETROCALHA LISA S/ VIROLA - REF. DP 700 / ABA 150 mm			Distância entre suportes em mm / Kg. Distance between supports (mm) / loads (Kg).				
ESPECIFICAÇÕES			1000 mm	1500 mm	2000 mm	2500 mm	3000 mm
Largura mm Width	Peso Kg Wight	Chapa Steel plate					
150	10,5	20	98	80	59	45	27
150	14,0	18	106	86	65	51	32
150	17,5	16	131	105	79	66	41
150	19,4	14	160	130	120	110	105
150	27,0	12	190	165	132	122	113
200	12,0	20	102	84	62	48	30
200	15,5	18	118	92	70	57	36
200	19,0	16	144	110	83	70	44
200	21,6	14	160	130	120	110	105
200	30,0	12	190	165	132	122	113
300	14,5	20	102	84	62	48	30
300	18,5	18	135	105	80	64	40
300	23,0	16	159	113	86	79	49
300	26,0	14	186	138	120	110	105
300	36,0	12	190	165	132	122	113
400	21,5	18	160	118	88	69	43
400	26,5	16	170	131	99	79	49
400	30,2	14	197	150	120	110	105
400	42,0	12	190	165	132	122	113
500	23,0	18	160	118	88	69	43
500	30,5	16	172	140	106	84	53
500	35,0	14	197	164	122	110	105
500	48,0	12	205	170	132	122	115
600	34,0	16	185	145	110	94	60
600	39,5	14	200	175	128	113	105
600	54,0	12	210	182	140	122	116
700	38,0	16	203	157	119	104	65
700	44,0	14	210	180	132	115	105
700	60,0	12	230	192	144	124	116
800	41,5	16	203	173	120	106	66
800	48,5	14	210	183	132	115	105
800	66,0	12	235	195	144	125	116

Aplicação típica Typical application

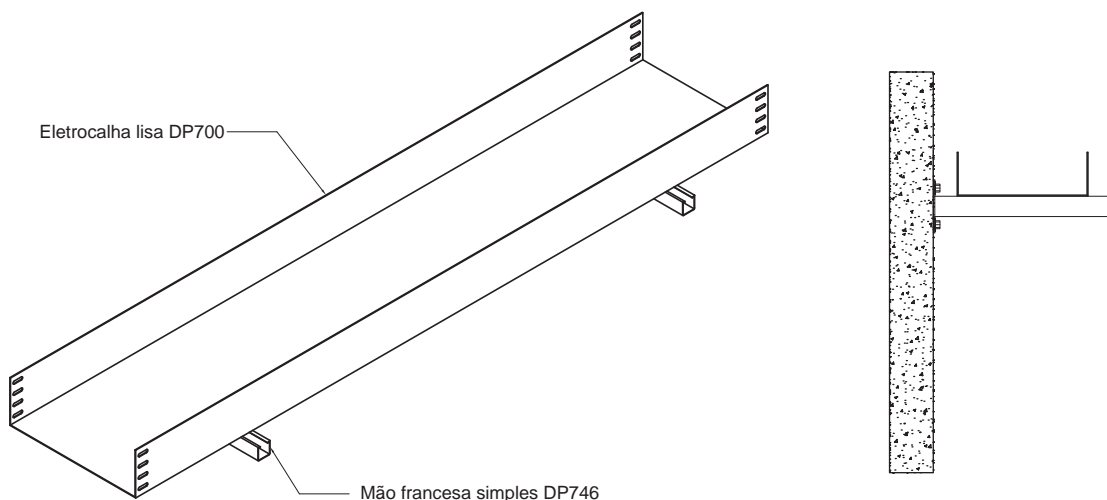

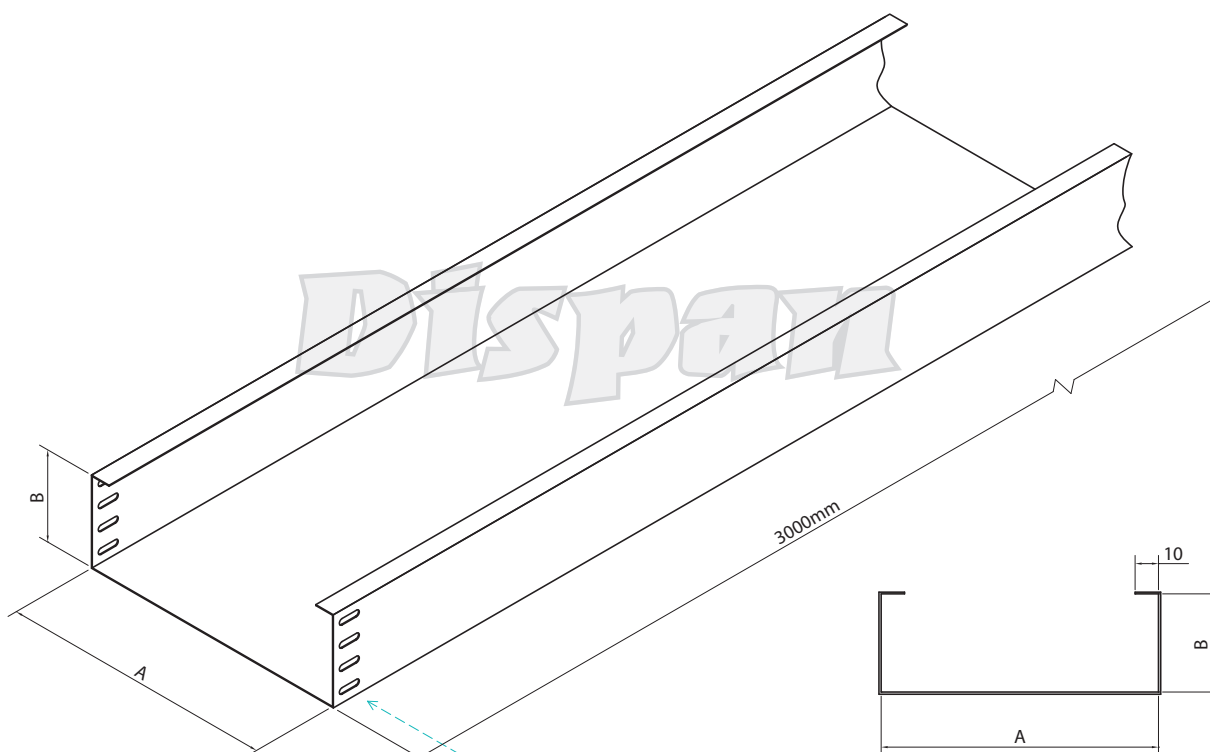

Aba de 50 mm

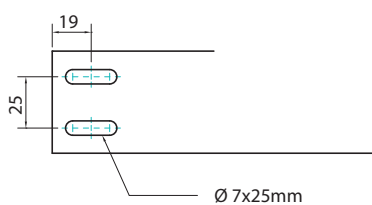

Aba de 75 mm

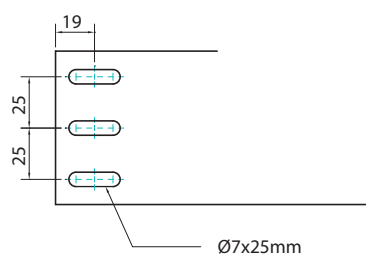

Aba de 100 mm

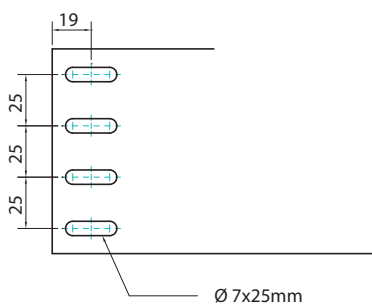

Aba de 150 mm

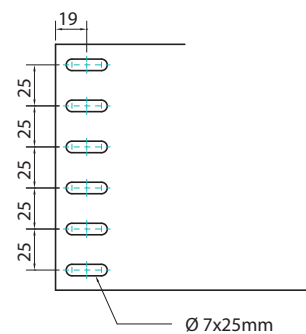

Obs.: Fabricamos eletrocalhas com virola externa para lacre.

Carga uniformemente distribuída entre suportes • DP: 701

Load Table.

ELETROCALHA LISA C/ VIROLA - REF. DP 701 / ABA 50 mm								
ESPECIFICAÇÕES			Distância entre suportes em mm / Kg. Distance between supports (mm) / loads (Kg).					
Largura mm Width	Peso Kg Wight	Chapa Steel plate	1000 mm	1500 mm	2000 mm	2500 mm	3000 mm	
50	2,8	22	70	48	40	30	20	
50	3,5	20	85	69	45	32	25	
50	4,5	18	110	88	52	40	30	
50	5,6	16	115	95	65	50	40	
50	6,5	14	185	170	145	134	125	
50	9,0	12	214	195	179	160	144	
75	3,4	22	72	62	41	32	21	
75	4,0	20	86	71	46	33	25	
75	5,2	18	105	88	54	42	31	
75	6,5	16	115	97	66	51	42	
75	7,5	14	185	172	155	145	125	
75	10,5	12	216	197	180	160	144	
100	3,9	22	78	65	45	34	24	
100	4,6	20	93	70	50	35	27	
100	6,0	18	120	88	70	55	40	
100	7,5	16	142	105	78	63	45	
100	8,7	14	185	172	165	145	125	
100	12,0	12	218	197	180	165	155	
150	4,8	22	88	72	48	35	25	
150	5,7	20	95	82	52	36	28	
150	7,5	18	120	88	70	55	40	
150	9,5	16	142	105	78	63	45	
150	10,8	14	198	177	165	145	125	
150	15,0	12	224	197	180	165	155	
200	5,8	22	92	72	52	40	30	
200	7,0	20	97	82	53	44	32	
200	9,0	18	120	88	70	55	40	
200	11,5	16	142	105	80	66	45	
200	12,9	14	200	178	165	145	125	
200	18,0	12	224	197	180	165	155	
300	9,5	20	103	85	62	51	34	
300	12,0	18	120	89	70	55	40	
300	15,0	16	142	105	80	66	45	
300	17,3	14	205	178	165	145	125	
300	24,0	12	228	198	180	165	155	
400	11,4	20	107	82	65	52	39	
400	15,0	18	110	84	65	49	40	
400	16,0	16	147	110	85	67	48	
400	21,6	14	185	172	147	135	125	
400	30,0	12	240	205	180	168	153	

Load Table.

ELETROCALHA LISA C/ VIROLA - REF. DP 701 / ABA 75 mm								
ESPECIFICAÇÕES			Distância entre suportes em mm / Kg. Distance between supports (mm) / loads (Kg).					
Largura mm Width	Peso Kg Wight	Chapa Steel plate	1000 mm	1500 mm	2000 mm	2500 mm	3000 mm	
75	4,5	22	69	56	47	33	24	
75	5,2	20	74	65	49	42	28	
75	6,8	18	88	75	65	46	37	
75	8,1	16	110	94	74	54	46	
75	9,7	14	183	172	163	142	122	
75	13,5	12	213	194	177	157	143	
100	5,0	22	75	55	49	33	25	
100	5,7	20	82	69	52	42	30	
100	7,5	18	93	81	64	43	37	
100	9,5	16	116	95	74	58	45	
100	10,8	14	197	178	163	142	127	
100	15,0	12	218	194	177	162	152	
150	6,0	22	77	58	51	36	25	
150	7,0	20	94	79	58	45	33	
150	9,0	18	123	98	65	56	36	
150	11,5	16	130	99	71	60	45	
150	13,0	14	198	178	163	142	127	
150	18,0	12	222	194	177	162	152	
200	7,0	22	77	62	51	36	25	
200	8,0	20	102	80	62	49	33	
200	10,5	18	123	98	65	56	37	
200	13,5	16	131	105	77	60	45	
200	15,1	14	198	178	163	142	127	
200	21,0	12	223	195	177	162	152	
300	10,5	20	105	82	66	51	38	
300	13,5	18	123	98	76	56	42	
300	17,0	16	135	120	86	70	45	
300	19,4	14	198	178	163	142	127	
300	27,0	12	227	198	177	162	152	
400	16,5	18	126	103	80	62	44	
400	20,5	16	148	122	83	70	48	
400	23,7	14	198	178	163	142	127	
400	33,0	12	238	203	178	162	152	
500	23,5	16	148	122	86	70	48	
500	28,0	14	198	178	163	142	127	
500	39,0	12	238	203	178	162	152	

Aplicação típica Typical application

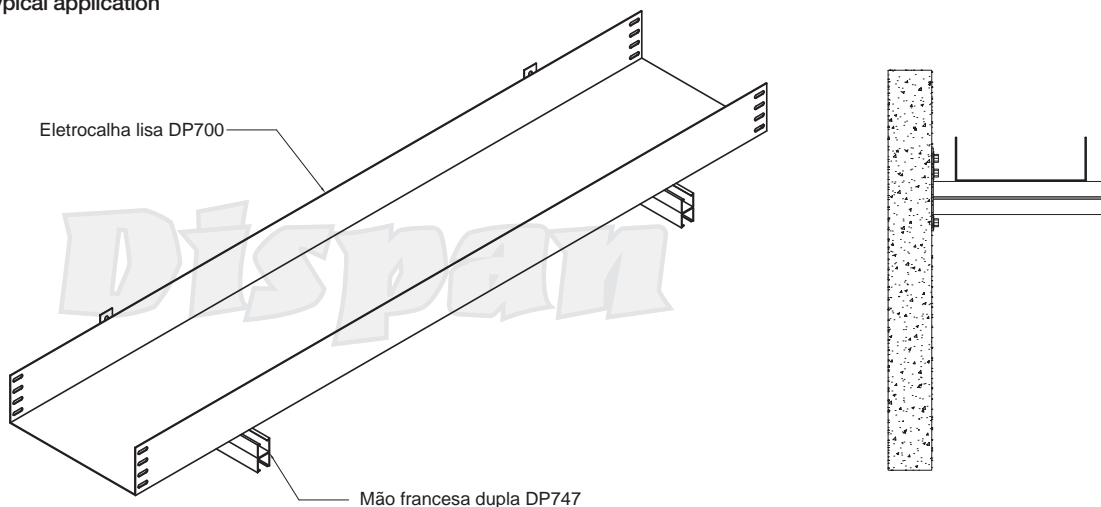

Carga uniformemente distribuída entre suportes • DP: 701

Load Table.

ELETROCALHA LISA C/ VIROLA - REF. DP 701 / ABA 100 mm								
ESPECIFICAÇÕES			Distância entre suportes em mm / Kg. Distance between supports (mm) / loads (Kg).					
Largura mm Width	Peso Kg Wight	Chapa Steel plate	1000 mm	1500 mm	2000 mm	2500 mm	3000 mm	
100	7,0	20	95	78	55	44	35	
100	9,0	18	135	100	70	50	40	
100	11,5	16	150	115	78	60	48	
100	13,0	14	195	174	138	124	114	
100	18,0	12	237	217	206	191	164	
150	8,0	20	118	85	70	50	36	
150	11,0	18	135	103	74	52	41	
150	13,5	16	150	115	89	72	48	
150	15,0	14	195	174	138	124	114	
150	21,0	12	238	220	206	191	166	
200	9,5	20	118	87	70	50	36	
200	12,5	18	142	105	75	60	42	
200	15,0	16	150	115	89	72	48	
200	17,5	14	195	174	138	124	114	
200	24,0	12	240	225	208	194	168	
300	12,0	20	129	100	70	55	41	
300	15,5	18	145	108	83	70	45	
300	19,0	16	155	115	90	72	48	
300	21,6	14	195	174	138	124	114	
300	30,0	12	242	225	208	194	168	
400	14,0	20	132	100	70	55	42	
400	18,5	18	150	115	85	69	47	
400	22,5	16	155	125	100	78	53	
400	25,9	14	195	174	138	124	114	
400	36,0	12	242	225	208	194	168	
500	21,5	18	160	132	105	81	55	
500	26,5	16	170	135	108	83	58	
500	30,5	14	205	174	138	124	114	
500	42,0	12	242	225	208	195	168	
600	24,5	18	185	150	110	85	60	
600	30,5	16	225	162	116	94	62	
600	35,0	14	242	178	137	124	114	
600	48,0	12	245	225	209	199	176	
700	26,0	18	194	155	107	93	58	
700	34,0	16	232	165	120	98	64	
700	39,5	14	250	188	152	124	114	
700	54,0	12	254	225	210	199	177	
800	38,0	16	235	168	130	105	74	
800	44,0	14	262	190	162	133	114	
800	60,0	12	268	230	210	199	177	

Load Table.

ELETROCALHA LISA C/ VIROLA - REF. DP 701 / ABA 150 mm								
ESPECIFICAÇÕES			Distância entre suportes em mm / Kg. Distance between supports (mm) / loads (Kg).					
Largura mm Width	Peso Kg Wight	Chapa Steel plate	1000 mm	1500 mm	2000 mm	2500 mm	3000 mm	
150	10,5	20	102	84	62	48	36	
150	14,0	18	115	93	75	54	42	
150	17,5	16	142	120	88	72	46	
150	19,4	14	190	174	142	130	114	
200	12,0	20	150	88	66	54	40	
200	15,5	18	126	96	85	70	48	
200	19,0	16	152	125	94	73	55	
200	21,6	14	193	175	142	130	116	
200	30,0	12	226	201	186	167	155	
300	14,5	20	110	94	72	55	44	
300	18,5	18	138	118	92	71	54	
300	23,0	16	162	130	106	82	58	
300	25,9	14	196	175	142	130	116	
300	36,0	12	227	201	187	167	155	
400	21,5	18	165	127	110	80	60	
400	26,5	16	174	136	116	84	64	
400	30,2	14	228	175	142	130	116	
400	42,0	12	232	203	190	167	155	
500	24,0	18	146	127	110	80	70	
500	28,7	16	184	145	116	88	74	
500	34,5	14	228	175	142	130	116	
500	48,0	12	232	203	190	167	155	
600	34,0	16	200	166	125	101	74	
600	39,5	14	228	180	142	130	116	
600	54,0	12	232	204	196	182	161	
600	48,0	12	232	203	190	167	155	
600	34,0	16	200	166	125	101	74	
700	38,0	16	205	170	130	107	76	
700	44,0	14	228	206	160	130	116	
700	60,0	12	235	205	198	182	161	
800	41,5	16	210	174	136	110	80	
800	48,5	14	230	206	180	131	116	
800	66,0	12	248	208	198	182	161	

Aplicação típica Typical application

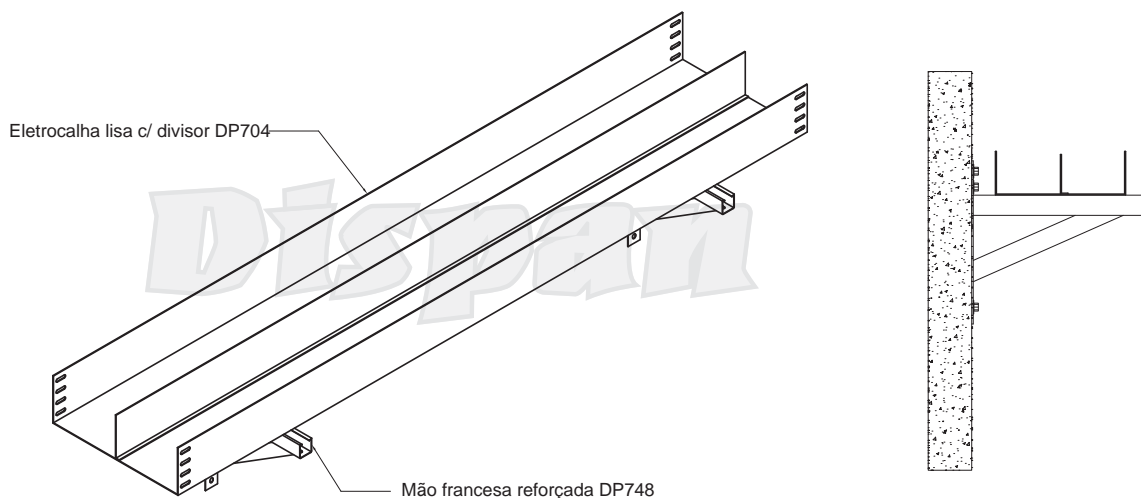

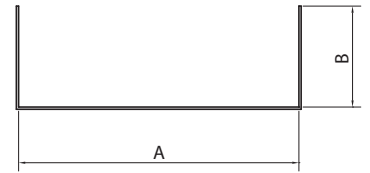
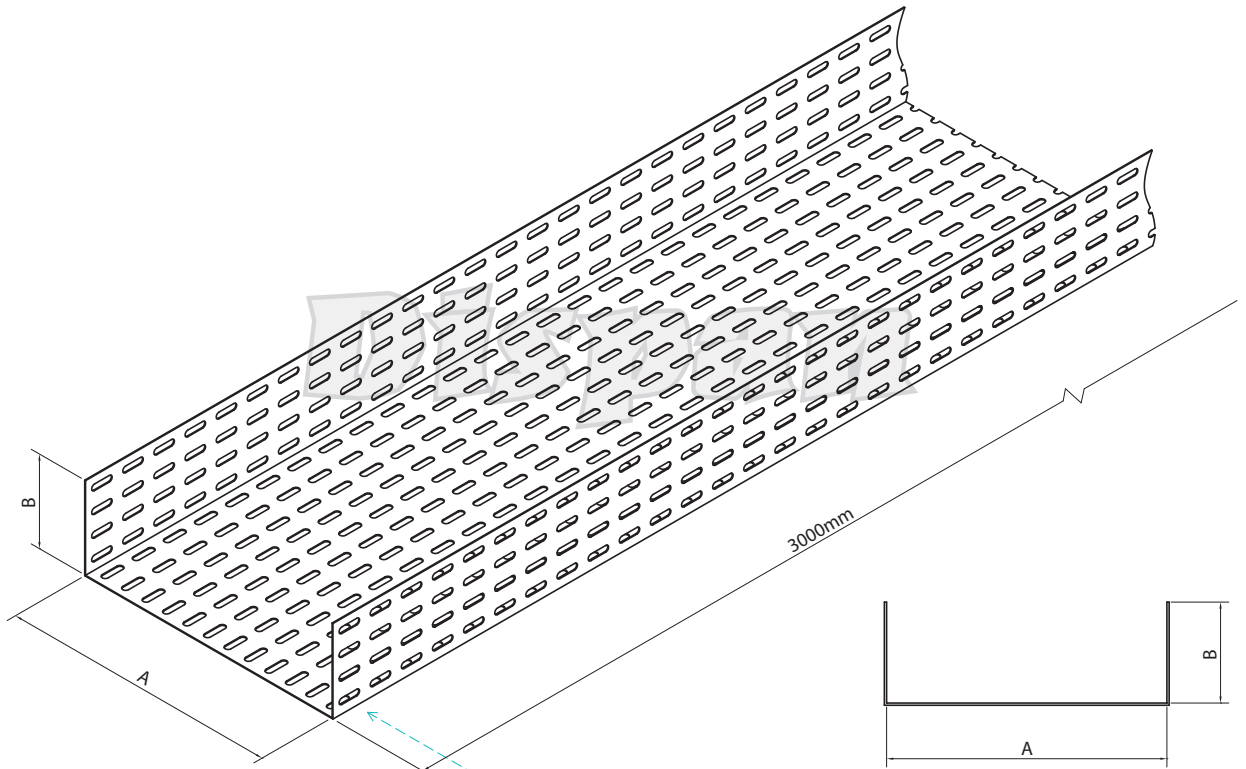

Aba de 50 mm

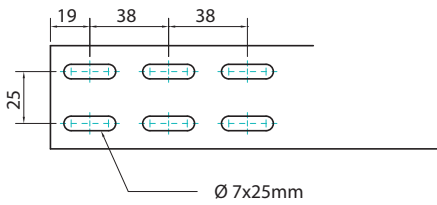

Aba de 75 mm

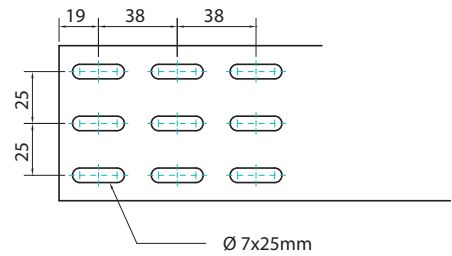

Aba de 100 mm

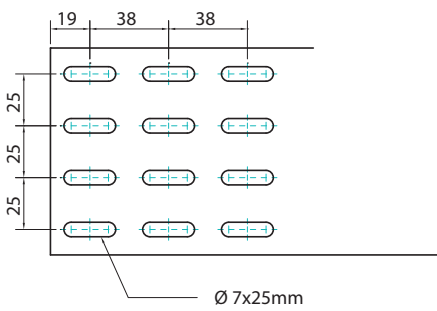

Aba de 150 mm

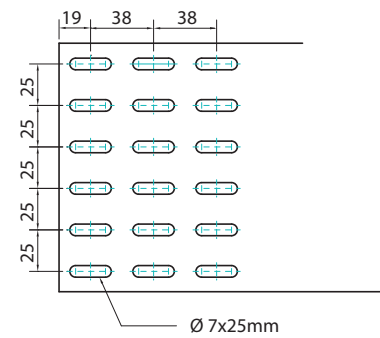

Obs.: Fabricamos com a base perfurada e aba lisa, sob consulta.

Carga uniformemente distribuída entre suportes • DP: 702

Load Table.

ELETROCALHA PERFORADA S/ VIOLA - REF. DP 702 / ABA 50 mm			Distância entre suportes em mm / Kg. Distance between supports (mm) / loads (Kg).				
ESPECIFICAÇÕES							
Largura mm Width	Peso Kg Wight	Chapa Steel plate	1000 mm	1500 mm	2000 mm	2500 mm	3000 mm
50	2,6	22	64	41	35	22	15
50	3,1	20	75	62	40	26	17
50	3,9	18	98	78	48	30	22
50	5,0	16	102	84	52	33	25
50	5,8	14	155	130	110	100	90
50	8,1	12	170	145	128	115	105
75	3,0	22	65	43	37	24	17
75	3,6	20	77	64	42	27	17
75	4,7	18	99	80	49	30	23
75	5,6	16	102	84	52	33	25
75	6,8	14	155	130	110	100	90
75	9,4	12	170	145	128	115	105
100	3,5	22	69	45	39	29	19
100	4,1	20	77	64	42	32	22
100	5,2	18	88	80	55	44	33
100	6,7	16	102	84	62	49	36
100	7,7	14	155	130	110	100	90
100	10,8	12	170	145	128	115	105
150	4,3	22	71	62	40	28	20
150	5,1	20	77	64	43	30	22
150	6,5	18	92	80	60	47	35
150	8,3	16	102	84	64	50	39
150	9,7	14	155	130	110	100	90
150	13,5	12	170	145	128	115	105
200	6,2	22	75	62	43	32	23
200	7,8	20	82	67	46	34	25
200	8,2	18	90	80	58	45	33
200	10,4	16	102	84	63	52	40
200	11,6	14	155	130	110	100	90
200	16,2	12	170	145	128	115	105
300	13,0	20	87	72	50	34	28
300	10,3	18	100	80	60	45	33
300	13,0	16	113	95	72	50	39
300	15,5	14	155	130	110	100	90
300	15,5	12	170	145	128	115	105
400	16,2	20	90	73	55	44	32
400	13,5	18	105	82	63	47	37
400	16,7	16	140	105	85	59	43
400	19,4	14	155	130	110	100	90
400	27,0	12	170	145	128	115	105

Load Table.

ELETROCALHA PERFORADA S/ VIOLA - REF. DP 702 / ABA 75 mm			Distância entre suportes em mm / Kg. Distance between supports (mm) / loads (Kg).				
ESPECIFICAÇÕES							
Largura mm Width	Peso Kg Wight	Chapa Steel plate	1000 mm	1500 mm	2000 mm	2500 mm	3000 mm
75	3,9	22	55	44	34	27	16
75	4,6	20	70	54	45	36	24
75	6,1	18	80	70	60	40	32
75	7,2	16	102	84	64	45	37
75	8,7	14	155	130	110	100	90
75	12,5	12	170	145	128	115	103
100	4,3	22	58	46	36	30	18
100	5,1	20	75	60	45	36	24
100	6,5	18	82	64	60	40	32
100	8,1	16	102	84	64	45	37
100	9,7	14	155	130	110	100	90
100	13,5	12	170	145	128	115	103
150	5,2	22	62	48	38	32	20
150	6,2	20	78	63	50	36	26
150	7,8	18	86	70	60	40	32
150	9,7	16	106	85	65	45	37
150	7,7	14	155	130	110	100	90
150	16,2	12	170	145	128	115	103
200	6,1	22	64	51	41	34	21
200	7,2	20	83	65	54	38	28
200	9,1	18	98	79	60	40	32
200	11,3	16	115	92	70	47	37
200	13,6	14	155	130	110	100	90
200	18,9	12	170	145	128	115	105
300	9,2	20	92	70	59	39	29
300	11,7	18	103	82	63	46	35
300	14,6	16	120	96	78	60	40
300	17,5	14	155	130	110	100	90
300	24,3	12	170	145	128	115	103
400	14,3	18	110	88	68	54	40
400	17,8	16	122	98	80	60	40
400	21,4	14	155	130	110	100	90
400	29,7	12	170	145	128	115	103
500	21,7	16	125	100	82	60	42
500	25,3	14	160	130	110	100	90
500	35,1	12	170	145	128	115	100

Aplicação típica Typical application

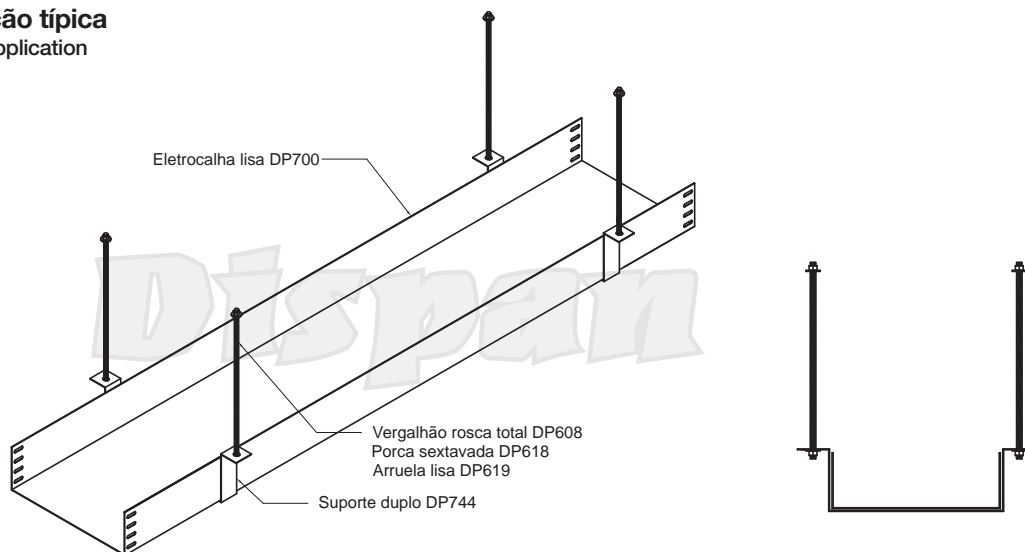

Carga uniformemente distribuída entre suportes • DP: 702

Load Table.

ELETROCALHA PERFORADA S/ VIOLA - REF. DP 702 / ABA 100 mm			Distância entre suportes em mm / Kg. Distance between supports (mm) / loads (Kg).				
ESPECIFICAÇÕES							
Largura mm Width	Peso Kg Wight	Chapa Steel plate	1000 mm	1500 mm	2000 mm	2500 mm	3000 mm
100	6,2	20	82	68	48	31	24
100	7,8	18	92	74	55	39	29
100	9,7	16	112	90	65	44	34
100	11,7	14	155	130	110	100	90
150	7,2	20	84	70	54	37	26
150	9,4	18	94	77	59	41	32
150	11,7	16	115	93	69	47	37
150	13,6	14	155	130	110	100	90
150	18,9	12	170	145	128	115	105
200	8,2	20	88	71	54	37	27
200	10,4	18	105	84	63	41	32
200	13,0	16	124	99	73	48	37
200	15,5	14	155	130	110	100	90
200	21,6	12	170	145	128	115	105
300	10,3	20	99	73	57	37	27
300	13,0	18	105	84	70	41	32
300	16,2	16	130	106	74	52	40
300	19,5	14	155	130	110	100	90
300	27,0	12	170	145	128	115	105
400	12,3	20	100	73	57	37	30
400	15,6	18	112	90	70	42	33
400	19,5	16	140	112	82	55	41
400	23,3	14	155	130	110	100	90
400	32,4	12	170	145	128	115	105
500	18,2	18	121	97	72	48	37
500	22,7	16	140	112	82	55	42
500	22,7	16	140	112	82	55	42
500	27,2	14	160	144	110	100	90
500	37,8	12	175	155	128	120	110
600	20,7	18	131	105	72	48	37
600	25,9	16	155	125	77	53	41
600	31,1	14	160	144	110	100	90
600	43,2	12	175	155	128	120	110
700	23,5	18	131	105	77	53	41
700	29,1	16	150	137	102	65	50
700	35,0	14	160	144	110	100	90
700	48,6	12	175	155	128	120	110
800	32,4	16	155	138	105	84	65
800	38,9	14	160	144	110	100	90
800	54,0	12	185	160	130	120	110

Load Table.

ELETROCALHA PERFORADA S/ VIOLA - REF. DP 702 / ABA 150 mm			Distância entre suportes em mm / Kg. Distance between supports (mm) / loads (Kg).				
ESPECIFICAÇÕES							
Largura mm Width	Peso Kg Wight	Chapa Steel plate	1000 mm	1500 mm	2000 mm	2500 mm	3000 mm
150	9,2	20	90	70	50	30	22
150	11,7	18	100	80	60	38	30
150	14,6	16	125	99	74	45	36
150	17,5	14	150	120	110	100	95
150	24,3	12	180	155	125	115	110
200	10,2	20	95	75	52	33	27
200	12,9	18	109	88	65	41	33
200	16,2	16	137	107	80	50	40
200	19,4	14	150	120	110	100	95
200	27,0	12	180	155	125	115	110
300	12,5	20	100	82	60	40	28
300	15,6	18	120	96	70	44	35
300	19,4	16	137	110	80	52	41
300	23,3	14	170	136	110	100	95
300	32,4	12	185	160	125	115	110
400	18,1	18	130	105	77	50	40
400	22,7	16	145	115	85	58	46
400	27,2	14	180	145	110	100	95
400	37,8	12	185	160	125	115	110
500	20,9	18	130	105	77	50	40
500	25,9	16	162	130	95	61	49
500	31,1	14	180	162	120	100	95
500	43,2	12	200	165	130	115	110
600	29,1	16	170	130	102	70	55
600	35,0	14	180	162	120	100	95
600	48,6	12	200	165	130	115	110
700	32,4	16	170	140	110	77	60
700	38,9	14	180	162	120	100	95
700	54,0	12	200	170	135	115	110
800	35,6	16	170	151	110	84	63
800	42,7	14	180	162	120	100	95
800	59,4	12	200	170	135	115	110

Aplicação típica Typical application

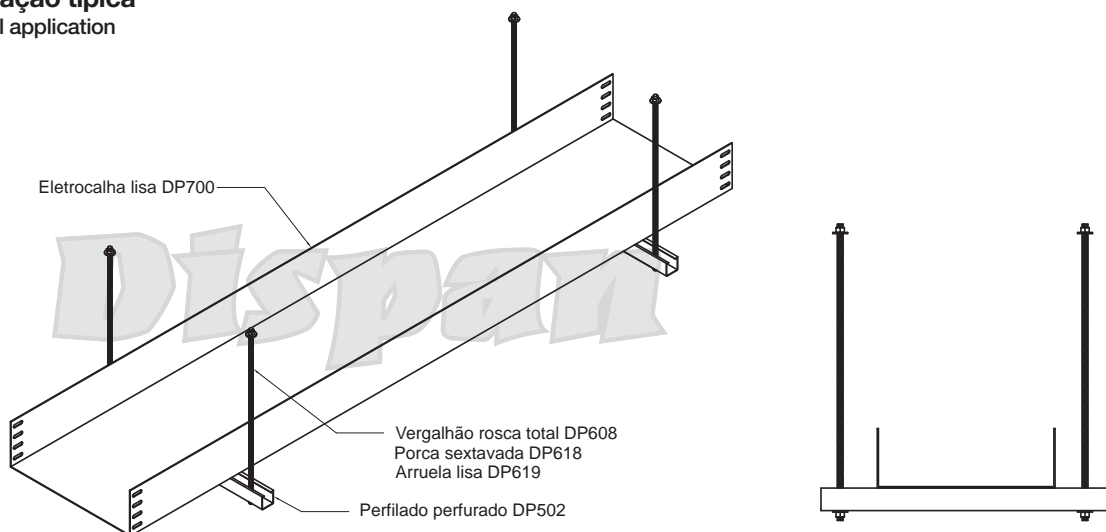

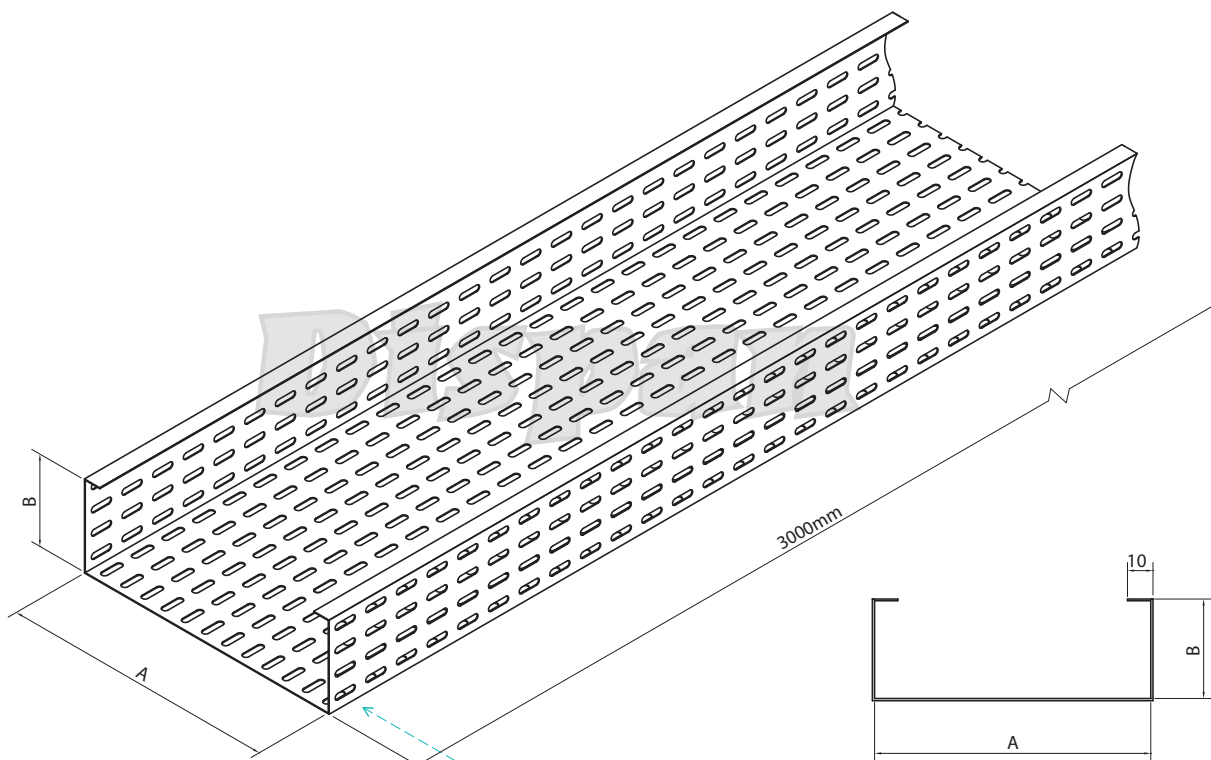

Aba de 50 mm

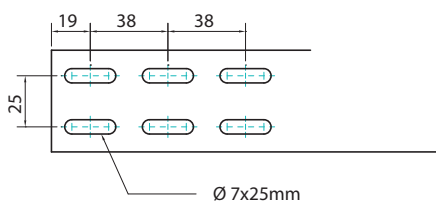

Aba de 75 mm

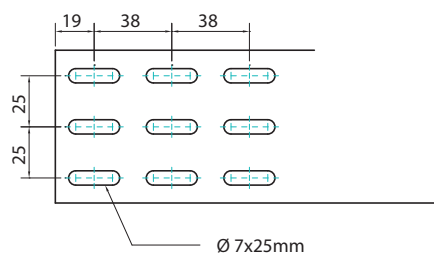

Aba de 100 mm

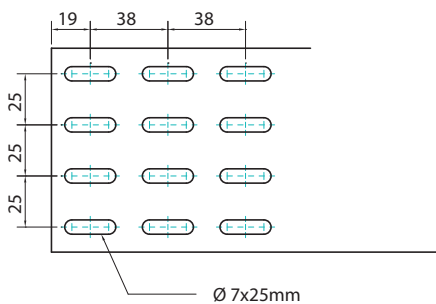

Aba de 150 mm

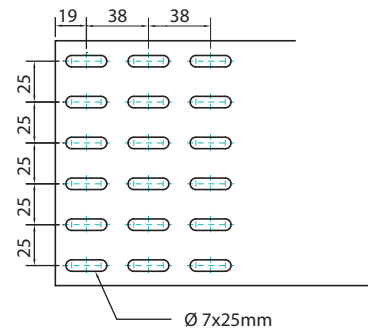

Obs.: Fabricamos com a base perfurada e aba lisa, sob consulta.

Carga uniformemente distribuída entre suportes • DP: 703

Load Table.

ELETROCALHA PERFORADA C/ VIROLA - REF. DP 703 / ABA 50 mm							
ESPECIFICAÇÕES			Distância entre suportes em mm / Kg. Distance between supports (mm) / loads (Kg).				
Largura mm Width	Peso Kg Wight	Chapa Steel plate	1000 mm	1500 mm	2000 mm	2500 mm	3000 mm
50	2,6	22	66	51	38	25	16
50	3,1	20	77	64	42	32	20
50	3,9	18	100	80	50	37	25
50	5,0	16	105	88	56	43	33
50	5,8	14	180	170	160	140	120
50	8,1	12	210	190	175	155	140
75	3,0	22	68	52	39	29	20
75	3,6	20	83	68	45	33	21
75	4,7	18	100	82	51	39	26
75	5,6	16	105	88	56	43	33
75	6,8	14	180	170	160	140	120
75	9,4	12	210	190	175	155	140
100	3,5	22	72	52	41	31	20
100	4,1	20	83	68	45	33	23
100	5,2	18	98	82	57	46	35
100	6,7	16	115	90	72	58	40
100	7,7	14	195	175	160	140	120
100	10,8	12	215	190	175	155	150
150	4,3	22	86	70	43	31	23
150	5,1	20	90	68	46	36	25
150	6,5	18	102	82	62	50	37
150	5,2	16	120	92	74	61	42
150	9,7	14	195	175	160	140	120
150	13,5	12	220	190	175	160	150
200	6,2	22	99	70	50	38	25
200	7,8	20	95	75	52	41	29
200	8,2	18	102	82	62	48	37
200	10,4	16	122	94	78	64	44
200	11,6	14	195	175	160	140	120
200	16,2	12	220	190	175	160	150
300	13,0	20	100	83	60	49	33
300	10,3	18	105	88	64	51	37
300	13,0	16	122	101	78	64	44
300	15,0	14	200	175	160	140	120
300	21,6	12	225	195	175	160	150
400	16,2	20	100	83	60	50	33
400	13,5	18	122	103	71	57	38
400	16,7	16	150	121	90	72	48
400	19,4	14	210	175	160	140	120
400	27,0	12	235	200	175	160	150

Load Table.

ELETROCALHA PERFORADA C/ VIROLA - REF. DP 703 / ABA 75 mm							
ESPECIFICAÇÕES			Distância entre suportes em mm / Kg. Distance between supports (mm) / loads (Kg).				
Largura mm Width	Peso Kg Wight	Chapa Steel plate	1000 mm	1500 mm	2000 mm	2500 mm	3000 mm
75	3,9	22	65	50	45	31	20
75	4,6	20	72	60	48	40	26
75	6,1	18	82	72	62	42	34
75	7,2	16	105	88	66	47	38
75	8,7	14	180	170	160	140	120
75	12,5	12	210	190	175	155	140
100	4,3	22	68	52	47	32	22
100	5,1	20	80	67	50	40	25
100	6,5	18	87	72	62	42	34
100	8,1	16	105	88	66	47	38
100	9,7	14	195	175	160	140	125
100	13,5	12	215	190	175	155	140
150	5,2	22	70	54	50	33	23
150	6,2	20	92	71	55	39	29
150	9,7	18	93	75	61	48	33
150	10,7	16	110	88	70	54	40
150	11,6	14	195	175	160	140	125
150	16,2	12	220	190	175	155	140
200	6,1	22	75	55	50	36	24
200	7,2	20	100	78	60	47	31
200	9,1	18	106	80	64	51	36
200	11,3	16	125	95	75	57	42
200	13,6	14	195	175	160	140	125
200	18,9	12	220	190	175	155	140
300	10,3	20	100	78	60	47	31
300	11,7	18	113	89	75	51	36
300	14,6	16	130	101	80	62	43
300	17,5	14	195	175	160	140	125
300	24,3	12	225	195	175	155	140
400	14,3	18	121	93	78	61	42
400	17,8	16	135	104	82	65	47
400	21,4	14	195	175	160	140	125
400	33,0	12	235	200	175	155	150
500	23,5	16	135	104	82	65	47
500	28,1	14	195	175	160	140	125
500	39,0	12	235	200	175	155	150

Aplicação típica Typical application

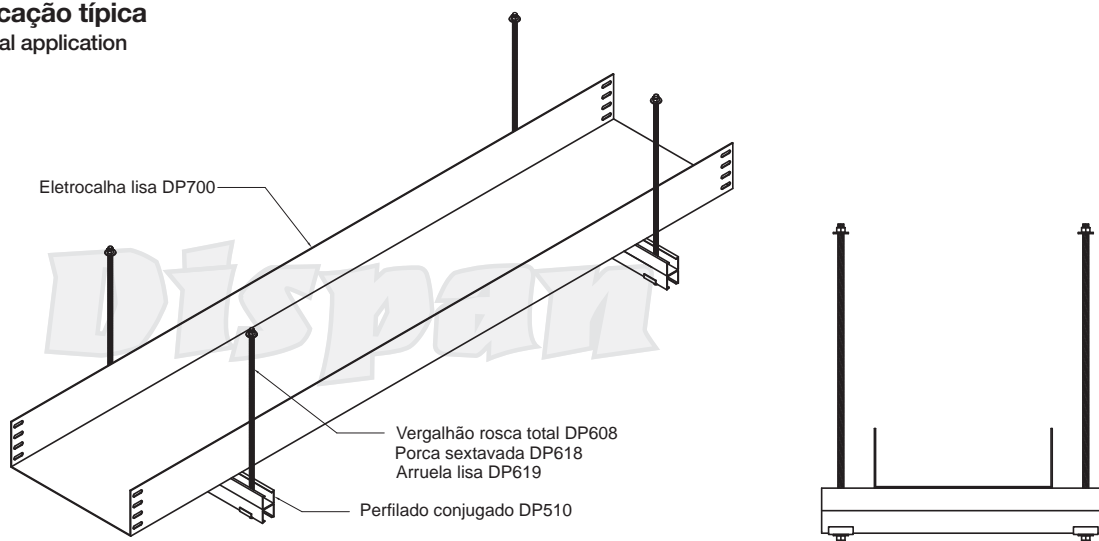

Carga uniformemente distribuída entre suportes • DP: 703

Load Table.

ELETROCALHA PERFORADA C/ VIROLA - REF. DP 703 / ABA 100 mm			Distância entre suportes em mm / Kg. Distance between supports (mm) / loads (Kg).				
ESPECIFICAÇÕES							
Largura mm Width	Peso Kg Wight	Chapa Steel plate	1000 mm	1500 mm	2000 mm	2500 mm	3000 mm
100	6,2	20	88	70	52	35	28
100	7,8	18	95	46	57	41	32
100	9,7	16	122	100	75	55	40
100	11,7	14	175	170	135	120	110
100	16,2	12	235	215	200	185	160
150	7,4	20	94	75	55	39	32
150	9,4	18	98	79	62	42	35
150	11,7	16	125	105	80	58	43
150	13,6	14	175	170	135	120	110
150	18,9	12	235	215	200	185	160
200	8,2	20	94	75	58	40	32
200	10,4	18	115	97	72	57	35
200	13,0	16	135	107	84	63	45
200	15,5	14	175	170	135	120	110
200	21,6	12	235	215	200	185	160
300	10,3	20	106	82	63	50	32
300	13,0	18	125	102	80	67	40
300	16,2	16	140	108	87	71	45
300	19,5	14	175	170	135	120	110
300	27	12	235	215	200	185	160
400	12,3	20	106	82	63	50	32
400	15,6	18	130	103	84	67	42
400	19,5	16	145	115	90	76	48
400	23,3	14	178	170	135	120	110
400	32,4	12	235	215	200	185	160
500	18,2	18	133	105	91	70	45
500	22,7	16	155	119	95	76	50
500	27,2	14	192	170	135	120	110
500	37,8	12	235	215	200	185	160
600	20,7	18	182	147	98	80	48
600	25,9	16	220	159	110	93	55
600	31,1	14	237	171	135	120	110
600	43,2	12	240	215	205	190	170
700	24,3	18	186	149	102	87	50
700	29,1	16	229	162	115	96	60
700	35,0	14	245	174	140	120	110
700	48,6	12	240	215	205	190	170
800	32,4	16	233	164	126	103	72
800	38,9	14	255	181	155	126	110
800	54,0	12	240	215	205	190	170

Load Table.

ELETROCALHA PERFORADA C/ VIROLA - REF. DP 703 / ABA 150 mm			Distância entre suportes em mm / Kg. Distance between supports (mm) / loads (Kg).				
ESPECIFICAÇÕES							
Largura mm Width	Peso Kg Wight	Chapa Steel plate	1000 mm	1500 mm	2000 mm	2500 mm	3000 mm
150	9,2	20	93	73	52	40	30
150	11,7	18	110	82	65	48	35
150	14,6	16	133	102	82	64	42
150	17,5	14	185	170	135	125	110
200	10,2	20	98	78	55	42	31
200	12,9	18	120	95	75	55	38
200	16,2	16	144	112	90	68	46
200	19,4	14	185	170	135	125	110
200	27,0	12	220	195	180	160	150
300	12,3	20	105	90	70	54	40
300	15,6	18	128	99	78	60	45
300	19,4	16	153	115	99	74	51
300	23,3	14	188	170	135	125	110
300	32,4	12	220	195	180	160	150
400	18,1	18	140	110	84	64	50
400	22,7	16	160	122	99	74	53
400	27,2	14	202	170	135	125	110
400	37,8	12	220	195	180	160	150
500	20,9	18	140	110	84	64	50
500	25,9	16	180	135	102	76	55
500	31,1	14	215	170	135	125	110
500	43,2	12	220	195	180	160	150
600	29,1	16	190	135	112	90	62
600	35,0	14	215	178	140	125	110
600	48,6	12	225	200	190	175	155
700	32,4	16	201	150	121	91	67
700	38,9	14	215	195	158	125	110
700	54,0	12	225	200	190	175	155
800	35,6	16	236	170	139	108	78
800	42,7	14	215	198	175	129	110
800	59,4	12	225	200	190	175	155

Aplicação típica Typical application

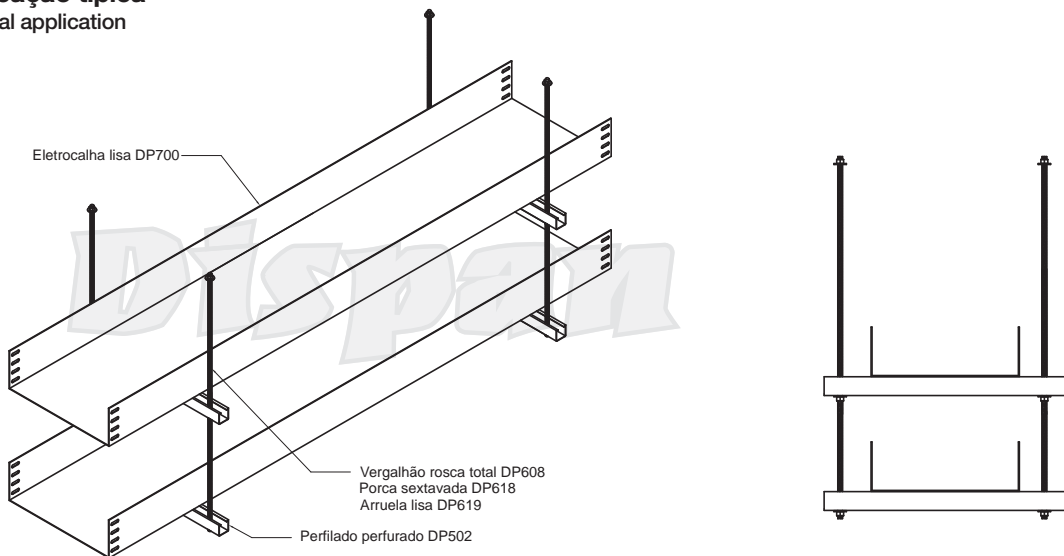

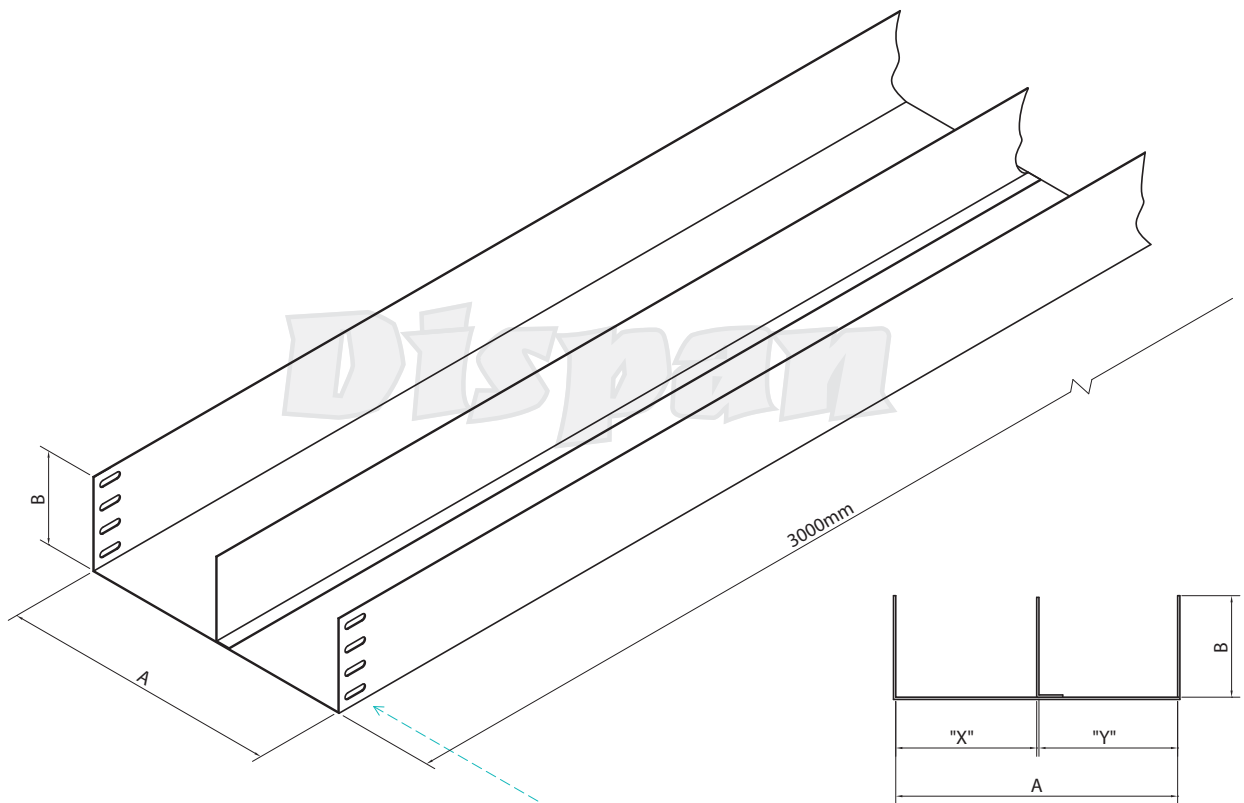

Aba de 50 mm

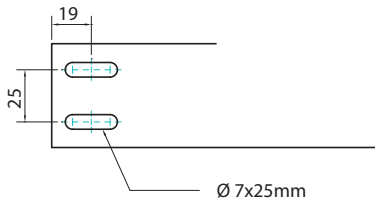

Aba de 75 mm

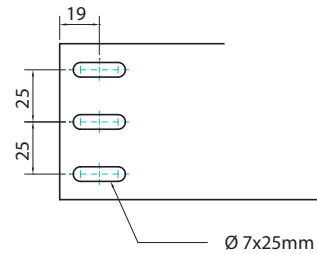

Aba de 100 mm

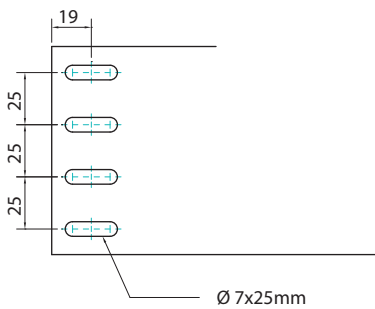

Aba de 150 mm

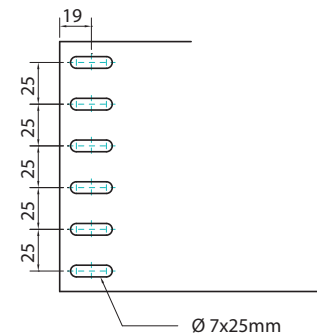

*Obs.: Para tabela de suportaço, verificar o DP700.

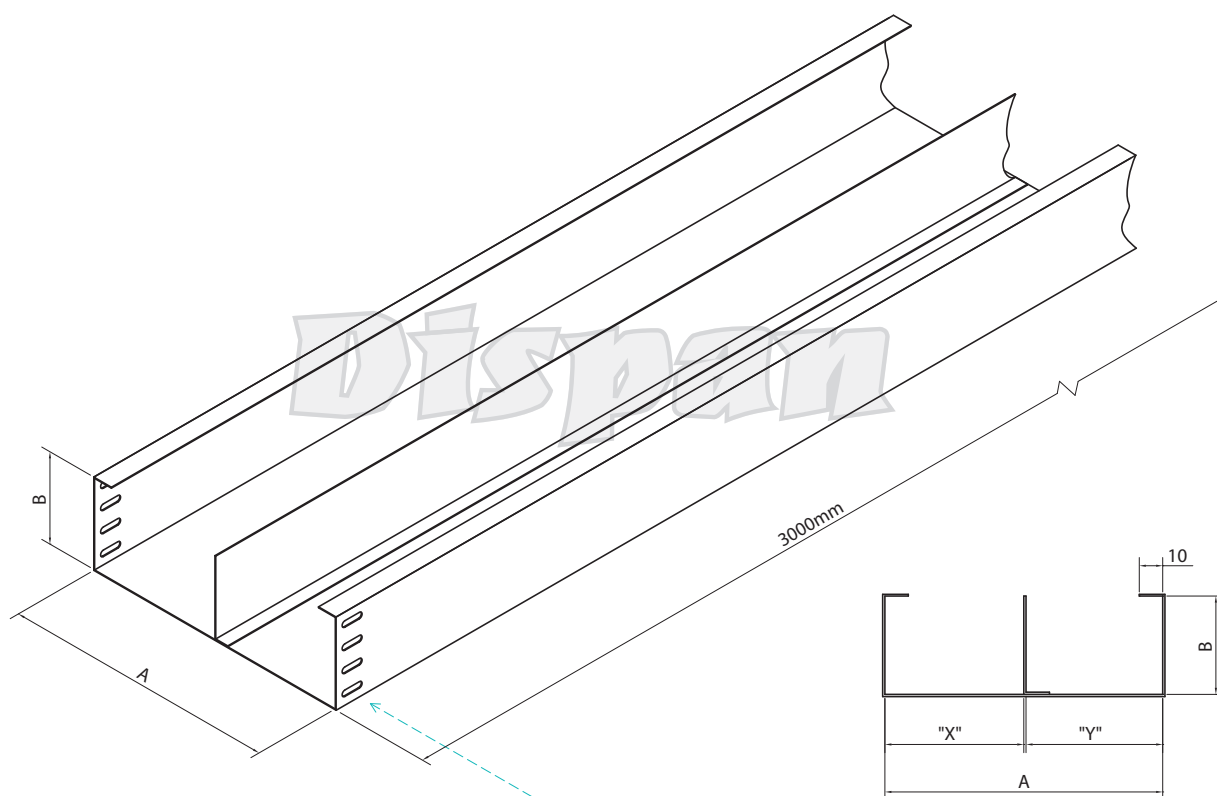

Aba de 50 mm

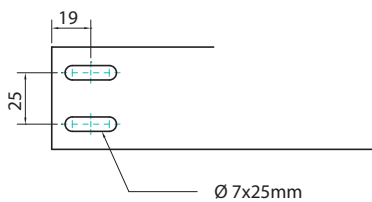

Aba de 75 mm

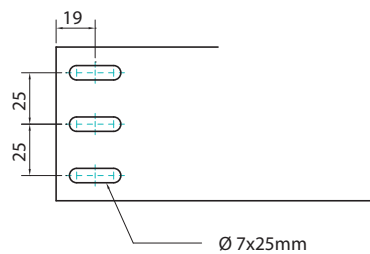

Aba de 100 mm

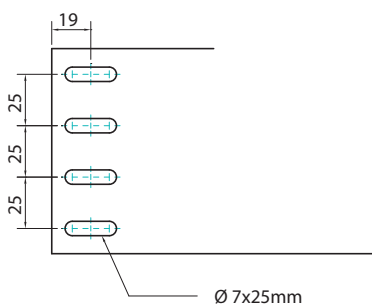

Aba de 150 mm

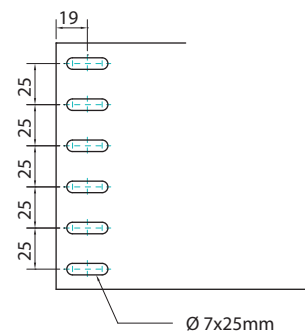

*Obs.: Para tabela de suportao, verificar o DP701.

Tampa de encaixe
Insert cover

DP: 706

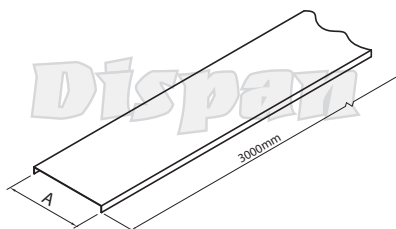

Tampa de pressão
Pressure cover

DP: 707

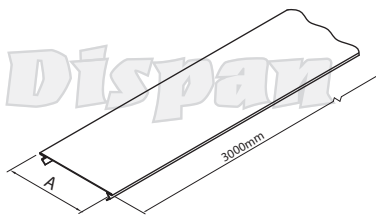

Obs.: Para conexões, consultar
tampas aparafusadas.

Tampa 2 águas de encaixe
Angular cover

DP: 706-2A

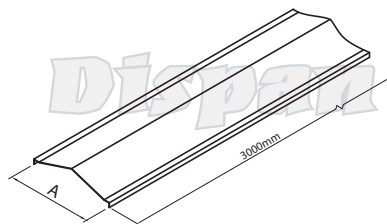

Obs.: Não fabricamos tampa
2 águas para conexões, vide DP859.
Largura mínima de 200 mm

Tampa 2 águas de pressão
Pressure angular cover

DP: 707-2A

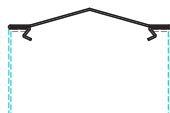
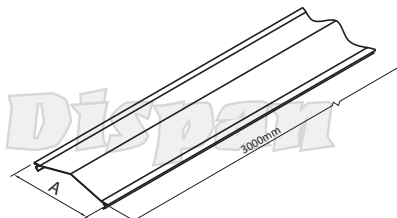

Obs.: Não fabricamos tampa
2 águas para conexões, vide DP859.
Largura mínima de 200 mm

Tampa Para Eletrocalha
Estrutural Com Virola 180°

Special pressure cover

DP: 706-E

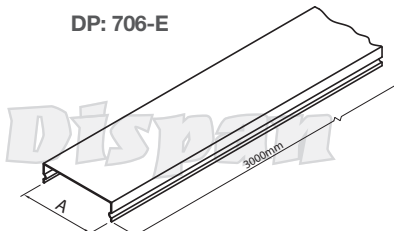

Tampa fecho rápido
Insert cover

DP: 706-FR

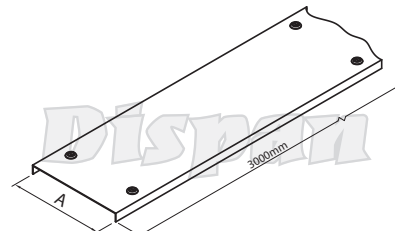

Tampa de encaixe aparafusada
Insert cover to screw

DP: 706-AP

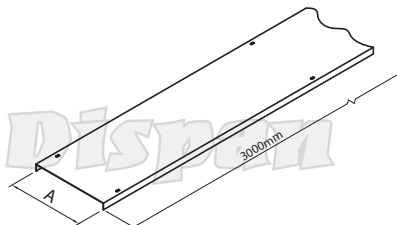

Obs.: Para a fixação, acompanham
parafuso autobrocante Ø 4,2 x 13 mm.
Largura mínima de 200 mm

Tampa de encaixe 2 águas
aparafusada

Angular cover to screw
DP: 706-AP2A

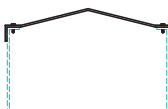
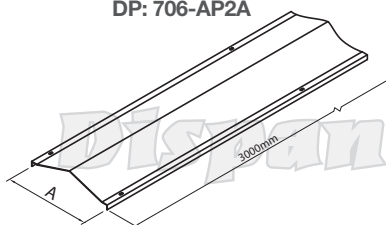

Obs.: Não fabricamos tampa
2 águas para conexões, vide DP859.
Largura mínima de 200 mm

Esquema de montagem
da tampa de 2 águas encaixe
c/ presilha

Typical applications to angular cover
with beam clamp

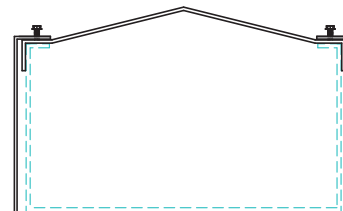

Esquema de montagem da tampa de encaixe c/ presilha

Typical applications to insert cover with beam clamp

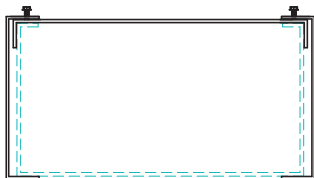

Esquema de montagem da tampa de encaixe c/ cinta para fechamento

Typical applications to angular cover with belt

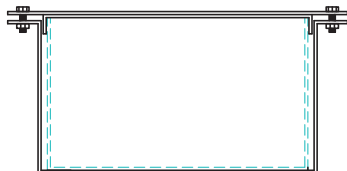

Septo divisor perfurado
Perforated divider

DP: 708

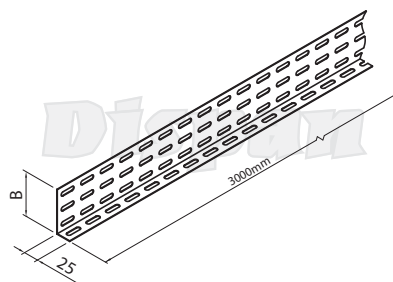

Obs.: Septo de 3000 mm apenas para o uso da tala, para o uso da emenda interna o septo é de 2850mm.

Septo divisor liso
Single divider

DP: 709

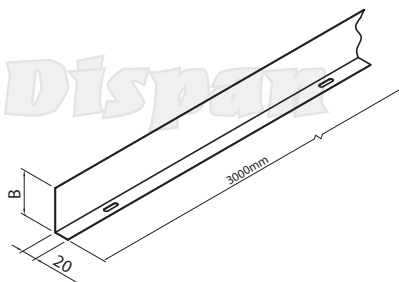

Obs.: Septo de 3000 mm apenas para o uso da tala, para o uso da emenda interna o septo é de 2850mm.

Parafuso cabeça lentilha c/ fenda
Lentil head bolt

DP: 612

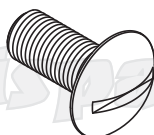

Rosca	Comprimento
1/4"	1/2"
1/4"	5/8"
1/4"	3/4"
5/16"	3/4"
3/8"	3/4"

Parafuso cabeça lentilha autotravante
Lentil head self lock bolt

DP: 613



Rosca	Comprimento
1/4"	1/2"
1/4"	5/8"
1/4"	3/4"
5/16"	3/4"
3/8"	3/4"

Porca sextavada
Hex nut

DP: 618

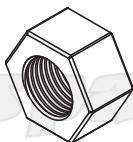

Rosca
1/4"
5/16"
3/8"
1/2"

Arruela lisa
Lock washer

DP: 619



Rosca
1/4"
5/16"
3/8"
1/2"

Vergalhão rosca total
Threaded rod

DP: 608



Tabela de carga.	
Diâmetros de vergalhão	Carga máxima
Vergalhão 1/4"	Kg 450
Vergalhão 5/16"	Kg 600
Vergalhão 3/8"	Kg 920
Vergalhão 1/2"	Kg 1250

Como solicitar conexões para eletrocalhas

How to specify connections for cable tray channel type.

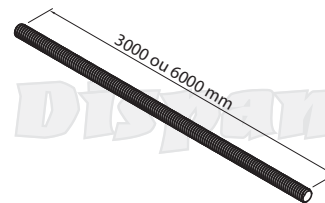
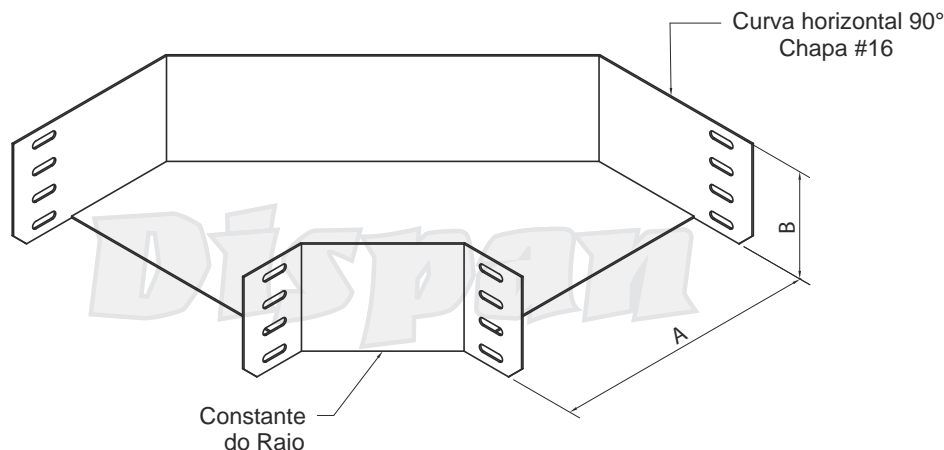

Exemplo
Example

DP 710 / 700 - AC - GF - 400/100 - 16 - R150

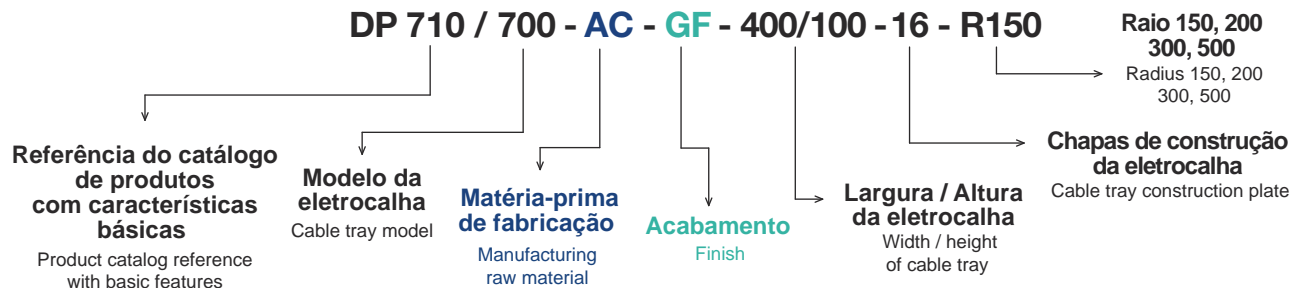

DP 710 • Curva horizontal 90°
DP 700 • Horizontal bend 90°

Matéria-prima base
Raw material base

AC - Aço carbono
Carbon Steel

AI - Aço inox
Stainless Steel

AL - Alumínio
Aluminum

Acabamento aplicado na matéria-prima em base de aço carbono
Finish applied to the raw material in carbon steel base

GF - Galvanizado à fogo por imersão
Hot dip galvanized

GE - Galvanizado eletrolítico
Electrolytic galvanized

NT - Natural
Natural

PT - Pintado
Painting

Largura:
400 - Largura da eletrocalha desejada (De 50 a 1500 mm).

Width: 400 - width of the wanted cable tray (50 to 1500mm)

Espessuras de chapas:
16 - Chapa de eletrocalha
Plate thickness: 16 - cable tray plate

*Para Solicitação da tampa, colocar o código + a letra "T": Exemplo = DP710T

Descritivo técnico | Technical description

DP 710 • Curva horizontal 90° para eletrocalha DP 700, em aço carbono, galvanizado à fogo, largura de 400 mm, com aba de 100 mm em chapa #16, raio de 150 mm, segmentada.

DP 710 • Horizontal bend 90° for cable tray DP700, carbon steel, hot dip galvanized, width of 400mm, with tab of 100mm in plate #16, radius of 150mm, segmented.

Nota - 1

Ocasionalmente podem ocorrer algumas distorções de medidas em nossas peças, por diversos fatores. Por este motivo damos uma tolerância de 5,0 mm entre as medidas mencionadas no catálogo e as peças reais. Os furos oblongos são feitos exatamente para compensação e ajuste de eventuais diferenças.

Note - 1

Occasionally, it may occur some distortion of measures in our pieces, for several reasons. Because of this, we give a toleration of 5.0 mm between the measures mentioned in.

Nota - 2

As conexões para eletrocalhas, tem como padrão virola de 10 mm, caso haja a necessidade fabricamos com virola de 25 mm, sob consulta.

Note - 2

The connections for cable tray have a standard ferrule of 10mm. In necessary case, we could manufacture ferrule with 25mm, under evaluation.

Nota - 3

Em caso de necessidade podemos fabricar as conexões de eletrocalhas no padrão antigo, sob consulta.

Note - 3

In necessary case, we could manufacture cable tray connections in old standard, under evaluation.

Curva horizontal 90° raio segmentado
Horizontal bend - 90°

DP: 710

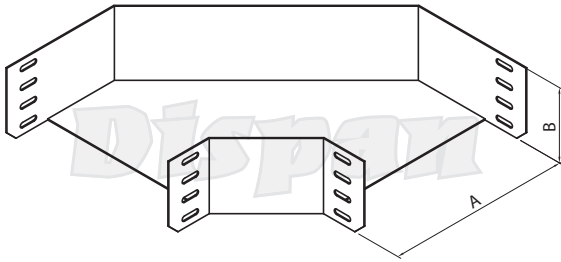

Indicar Cota A e B

Raio	C
150	87
200	116
300	175
500	292
D = A + C	

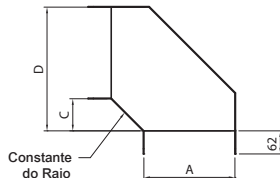

Curva horizontal 45° raio segmentado
Horizontal bend - 45°

DP: 711

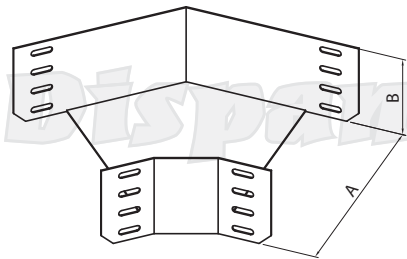

Indicar Cota A e B

Raio	C	D	D
150	57	100 = 70	600 = 424
200	75	200 = 141	700 = 495
300	114	300 = 212	800 = 565
500	191	400 = 283	900 = 636
E = C + D		500 = 353	1000 = 707

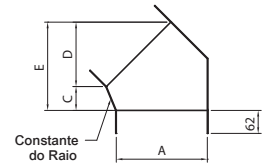

Curva vertical externa 90° raio segmentado
External vertical bend - 90°

DP: 712

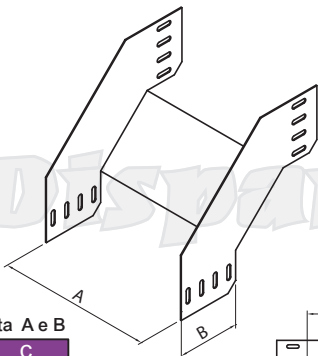

Indicar Cota A e B

Raio	C
150	87
200	116
300	175
500	292
D = B + C	

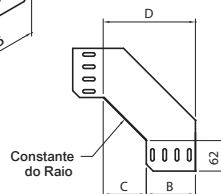

Curva vertical externa 45° raio segmentado
External vertical bend - 45°

DP: 713

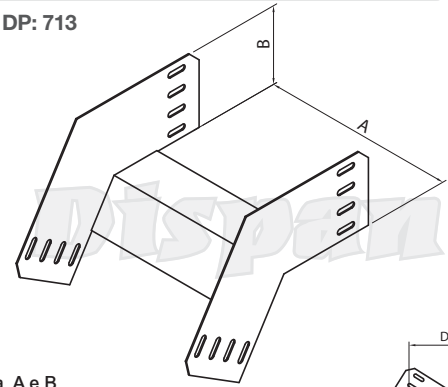

Indicar Cota A e B

Raio	C	E	F
150	29	40	69
200	57	80	137
300	57	80	137
500	57	80	137
D = B + C			

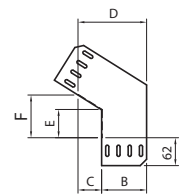

Curva vertical interna 90° raio segmentado
Internal vertical bend - 90°

DP: 714

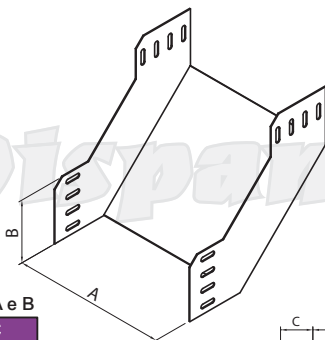

Indicar Cota A e B

Raio	C
150	87
200	116
300	175
500	292
D = B + C	

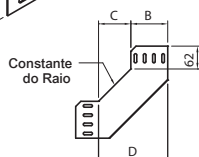

Curva vertical interna 45° raio segmentado
Internal vertical bend - 45°

DP: 715

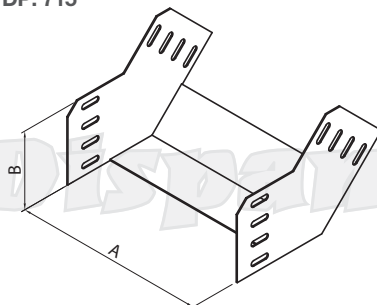

Indicar Cota A e B

Raio	C	E	F
150	29	40	69
200	57	80	137
300	57	80	137
500	57	80	137
D = B + C			

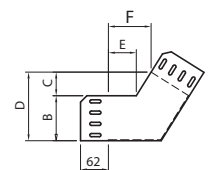

Tê horizontal 90° raio segmentado
Horizontal tee - 90°

DP: 716

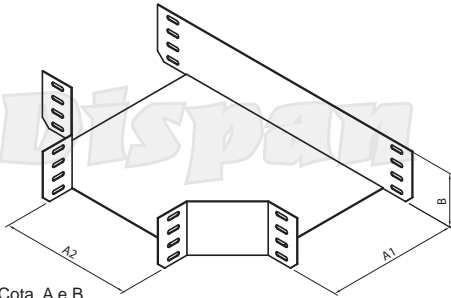

Indicar Cota A e B

Raio	C
150	87
200	116
300	175
500	292
D = A2 + (2 x C)	
E = A + C	

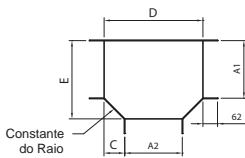

Tê vertical de descida 90° raio segmentado
Vertical descent tee - 90°

DP: 717

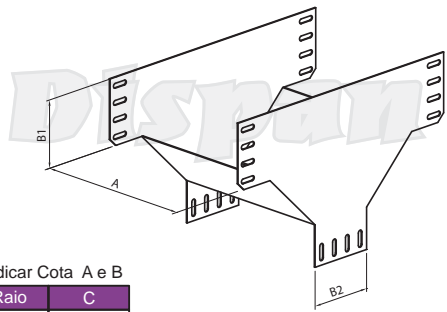

Indicar Cota A e B

Raio	C
150	87
200	116
300	175
500	292
D = B2 + (2 x C)	
E = B1 + C	

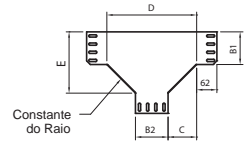

Tê vertical de subida 90° raio segmentado
Vertical ascent tee - 90°

DP: 718

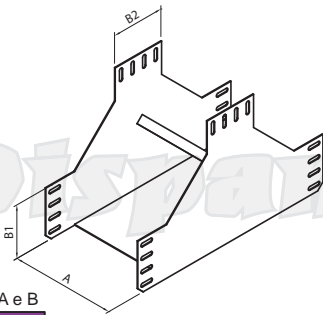

Indicar Cota A e B

Raio	C
150	87
200	116
300	175
500	292
D = B2 + (2 x C)	
E = B1 + C	

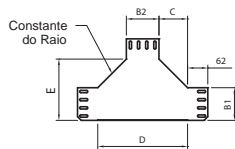

Tê vertical de descida lateral 90° raio segmentado
Lateral descent tee - 90°

DP: 719

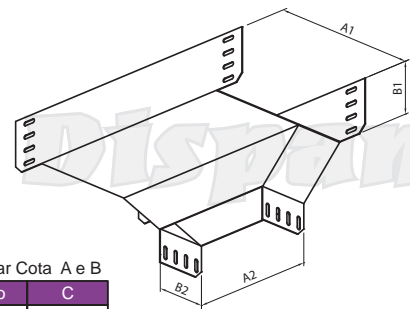

Indicar Cota A e B

Raio	C
150	87
200	116
300	175
500	292
D = A2 + (2 x C)	
E = B1 + C	

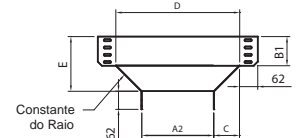

Cruzeta horizontal 90° raio segmentado
Horizontal cross - 90°

DP: 720

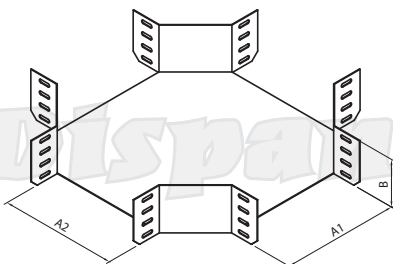

Indicar Cota A e B

Raio	C
150	87
200	116
300	175
500	292
D = A + (2 x C)	

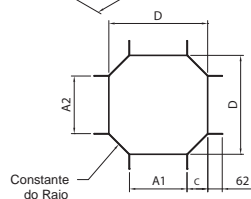

Curva de inversão 90° raio segmentado
Inversion bend - 90°

DP: 721

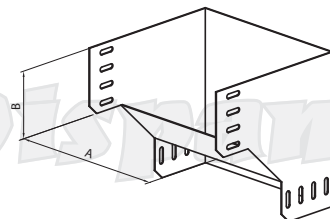

Indicar Cota A e B

Raio	C
150	87
200	116
300	175
500	292
D = B + C	

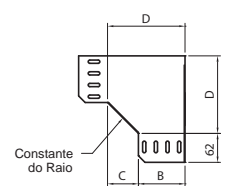

Tê reto 90° | Straight tee

DP: 722

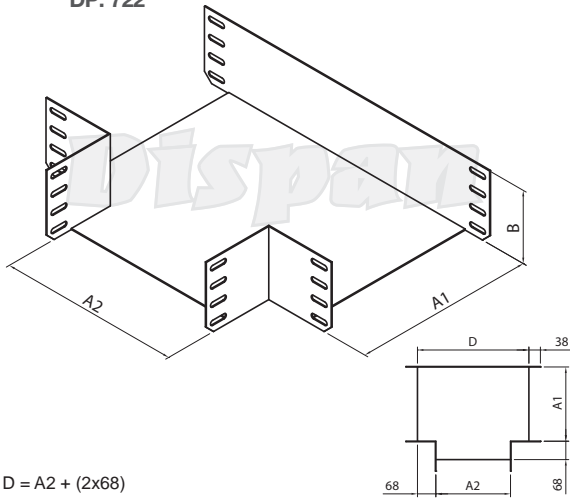

$D = A2 + (2 \times 68)$

Cotovelo reto 90° | Elbow - 90°

DP: 723

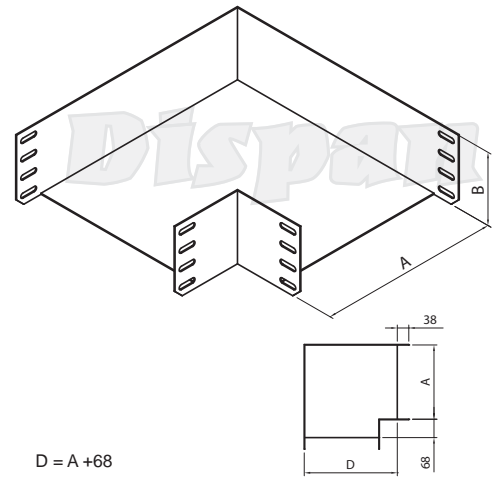

$D = A + 68$

Cruzeta reta 90° | Straight cross

DP: 724

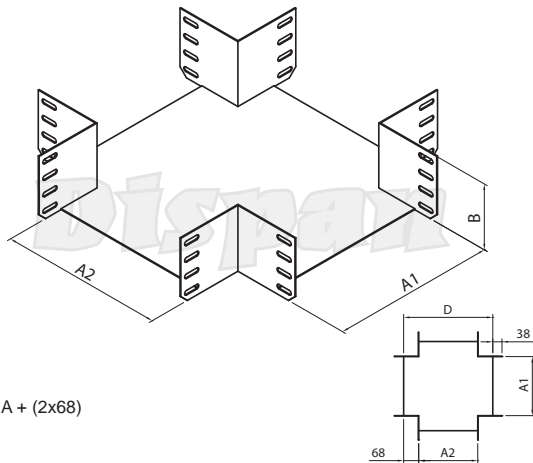

$D = A + (2 \times 68)$

**Curva com passagem reta subida 90°
raio segmentado**

90° Bend with ascent straight passage

DP: 725

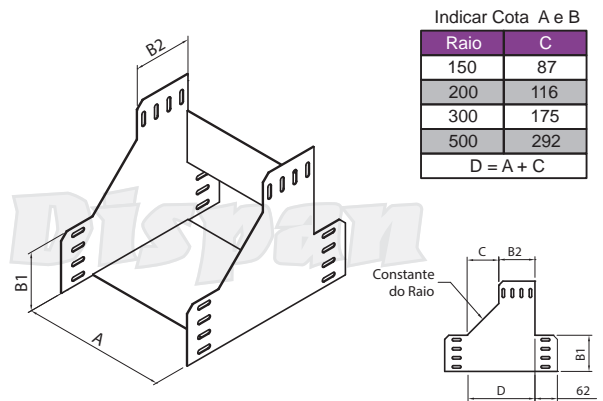

Segmento de montagem | Coupling enter connections

DP: 760

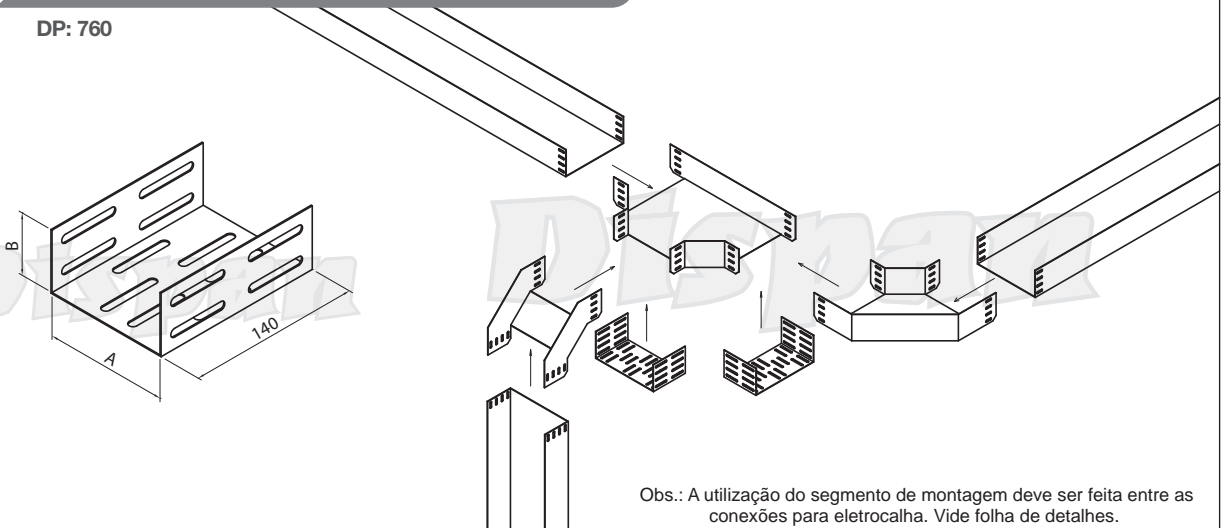

Obs.: A utilização do segmento de montagem deve ser feita entre as conexões para eletrocalha. Vide folha de detalhes.

Mata junta interna p/ curvas horizontais
Internal corner bracket for horizontal bends

DP: 770

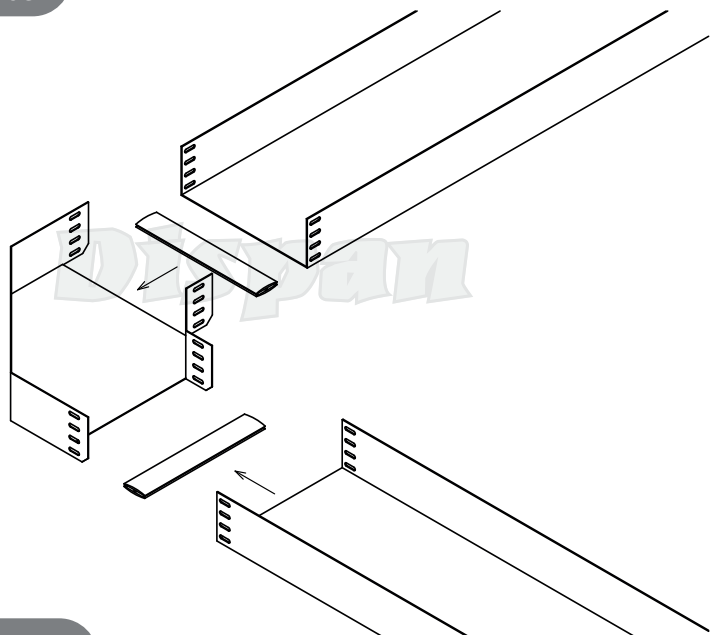
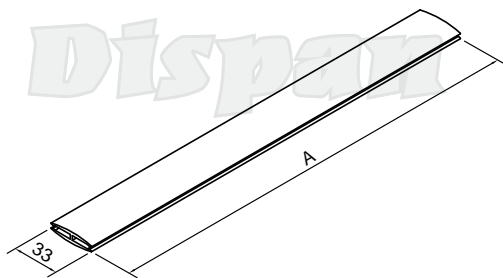

Mata junta interna p/ curvas verticais internas
Internal corner bracket for inside vertical bends

DP: 771

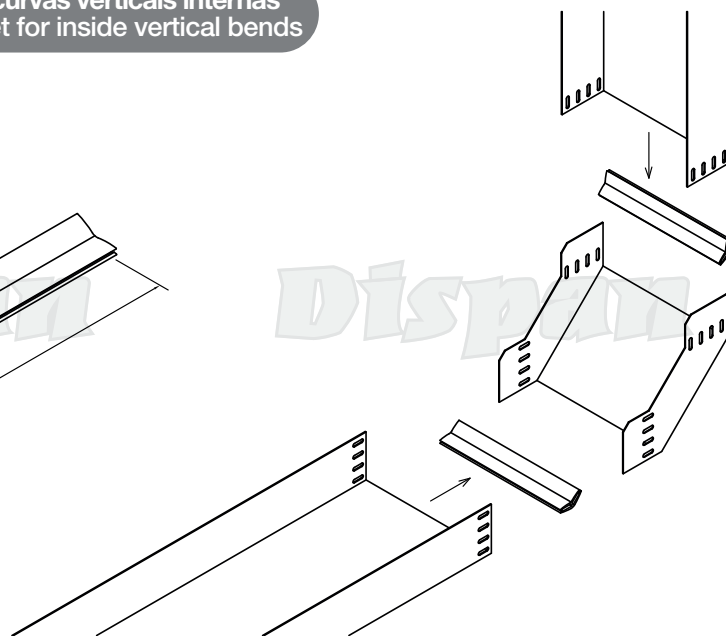
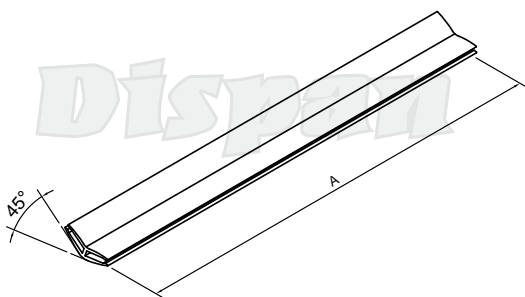

Mata junta interna p/ curvas verticais externas
Internal corner bracket for outside vertical bends

DP: 772

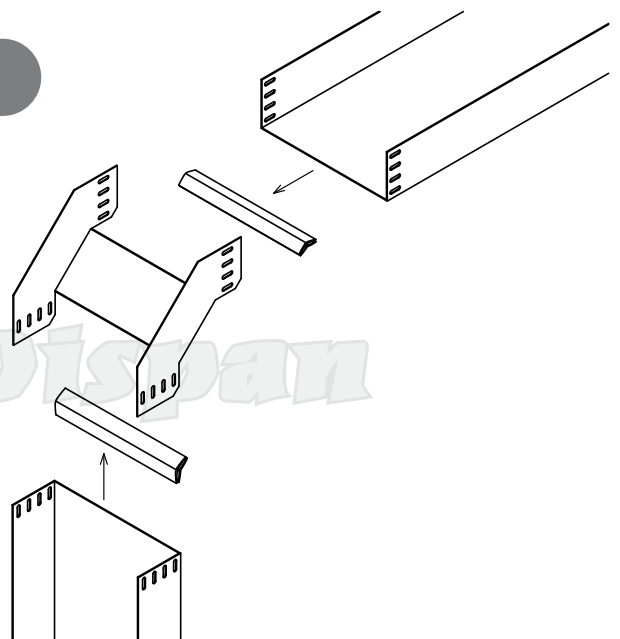
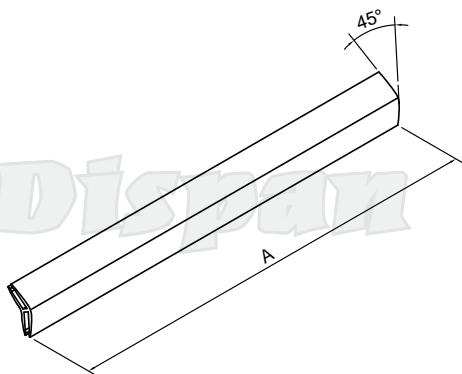

Montagem de mata junta interna p/ eletrocalhas
Application of internal corner bracket for cable tray channel type.

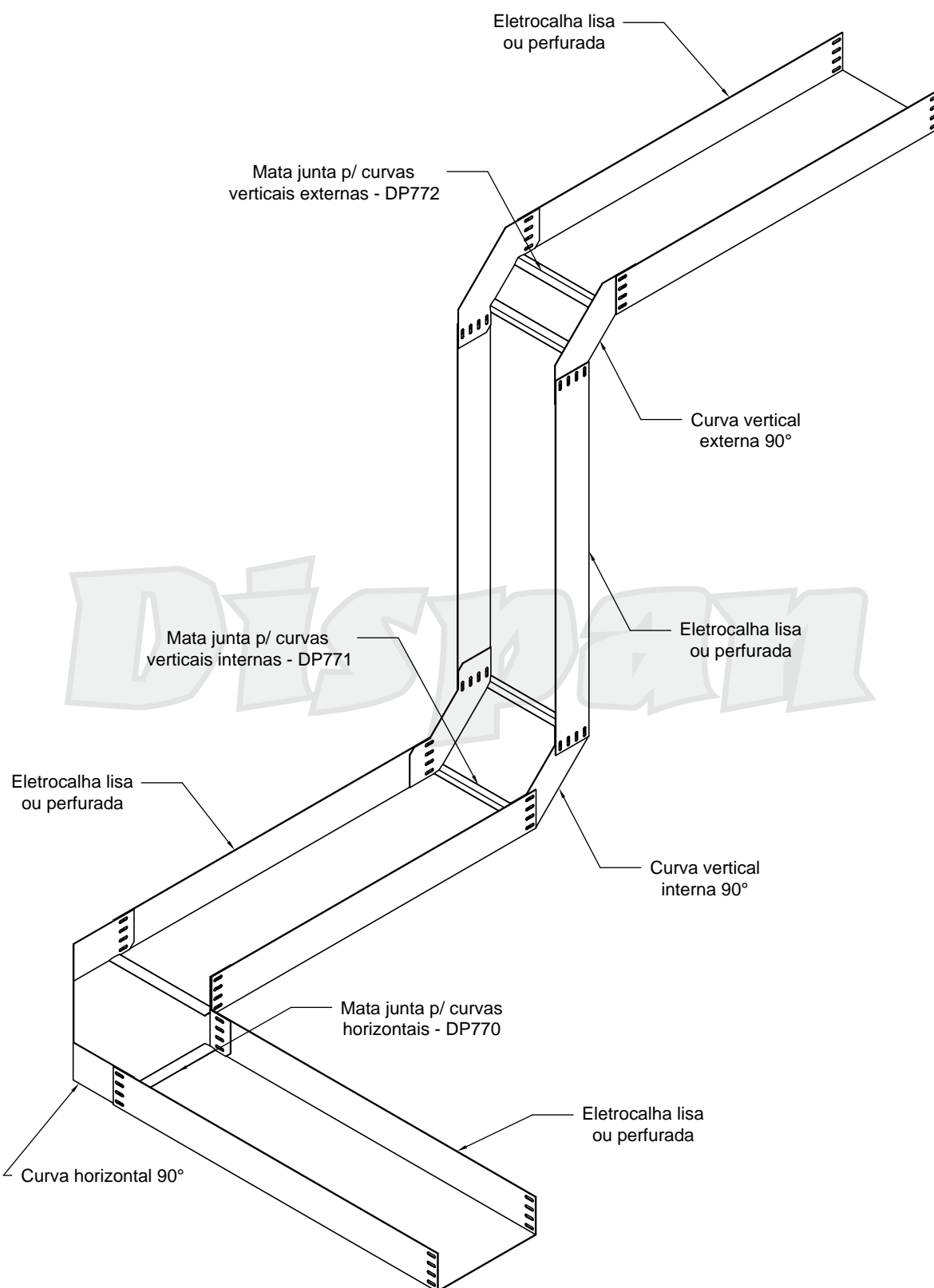

Junção à direita 45° | Right junction

DP: 726



Tabela dimensional		
A	C	D
50	131	128
75	166	170
100	201	213
150	272	298
200	343	384
250	413	469
300	484	554
400	626	725
500	767	896
600	908	1067
700	1050	1237
800	1191	1408
900	1333	1579
1000	1474	1749
1100	1616	1920
1200	1757	2091
1500	2181	2603

Junção à esquerda 45° | Left junction

DP: 727

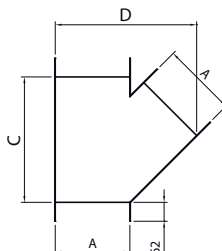
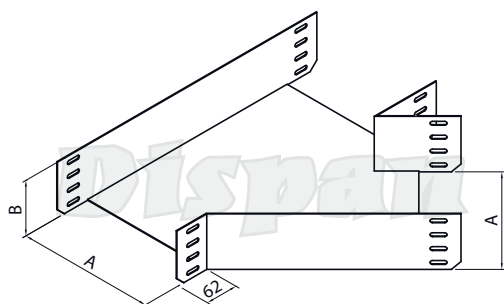

Tabela dimensional		
A	C	D
50	131	128
75	166	170
100	201	213
150	272	298
200	343	384
250	413	469
300	484	554
400	626	725
500	767	896
600	908	1067
700	1050	1237
800	1191	1408
900	1333	1579
1000	1474	1749
1100	1616	1920
1200	1757	2091
1500	2181	2603

Curva c/ passagem reta descida 90° raio segmentado | Horizontal tee - 90°

DP: 739

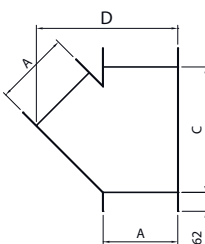
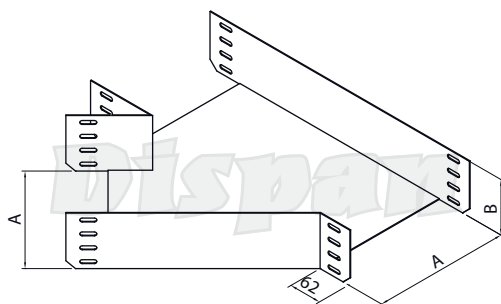
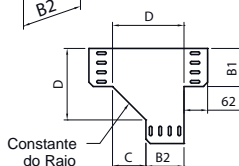
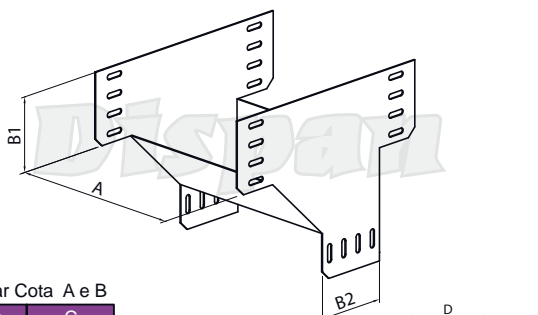

Indicar Cota A e B

Raio	C
150	87
200	116
300	175
500	292

D = B + C

Presilha p/ tampa em eletrocalha Cover plate beam clamp

DP: 761

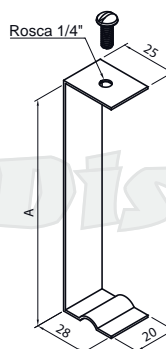

Presilha p/ eletrocalha
perfurada.

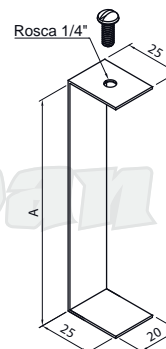

Presilha p/ eletrocalha
lisa.

Desvio horizontal à esquerda 45° | Left deviation

DP: 728

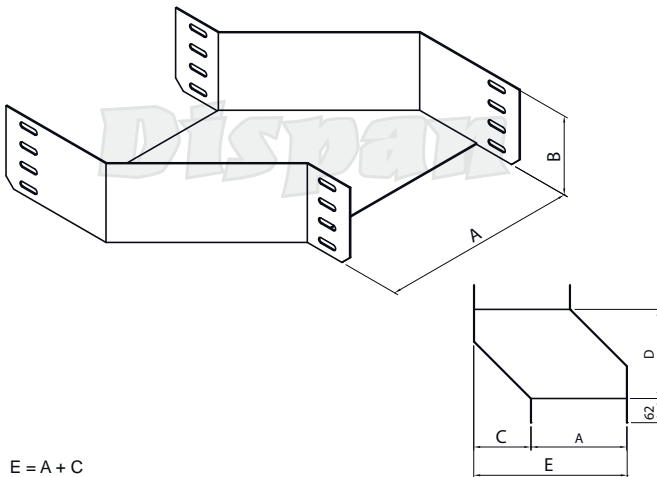

$E = A + C$

Tabela dimensional								
Raio 150		Raio 200		Raio 300		Raio 500		
C	D	C	D	A	C	D	C	D
150	171	200	221	50	300	321	500	521
150	181	200	231	75	300	331	500	531
150	191	200	241	100	300	341	500	541
150	212	200	262	150	300	362	500	562
150	233	200	283	200	300	383	500	583
150	253	200	303	250	300	403	500	603
150	274	200	324	300	300	424	500	624
150	316	200	365	400	300	466	500	665
150	357	200	407	500	300	507	500	707
150	398	200	448	600	300	548	500	748
150	440	200	490	700	300	590	500	790
150	481	200	531	800	300	631	500	831
150	523	200	573	900	300	673	500	873
150	564	200	614	1000	300	714	500	914
150	606	200	656	1100	300	756	500	956
150	647	200	697	1200	300	797	500	997
150	771	200	821	1500	300	921	500	1121

Desvio horizontal à direita 45° | Right deviation

DP: 729

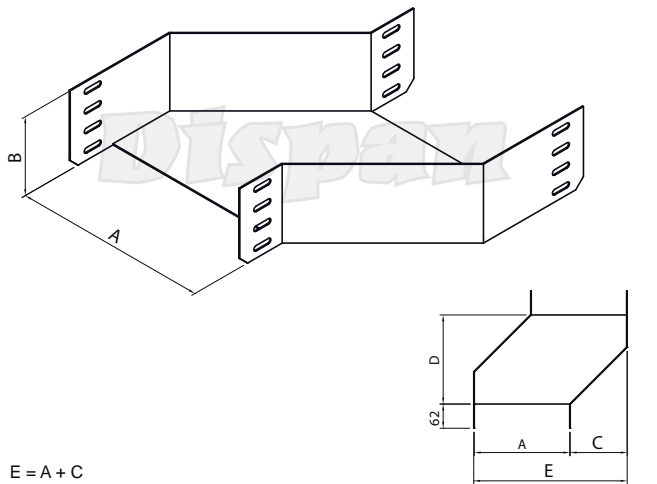

$E = A + C$

Tabela dimensional								
Raio 150		Raio 200		Raio 300		Raio 500		
C	D	C	D	A	C	D	C	D
150	171	200	221	50	300	321	500	521
150	181	200	231	75	300	331	500	531
150	191	200	241	100	300	341	500	541
150	212	200	262	150	300	362	500	562
150	233	200	283	200	300	383	500	583
150	253	200	303	250	300	403	500	603
150	274	200	324	300	300	424	500	624
150	316	200	365	400	300	466	500	665
150	357	200	407	500	300	507	500	707
150	398	200	448	600	300	548	500	748
150	440	200	490	700	300	590	500	790
150	481	200	531	800	300	631	500	831
150	523	200	573	900	300	673	500	873
150	564	200	614	1000	300	714	500	914
150	606	200	656	1100	300	756	500	956
150	647	200	697	1200	300	797	500	997
150	771	200	821	1500	300	921	500	1121

Redução concêntrica | Concentric reduction

DP: 730

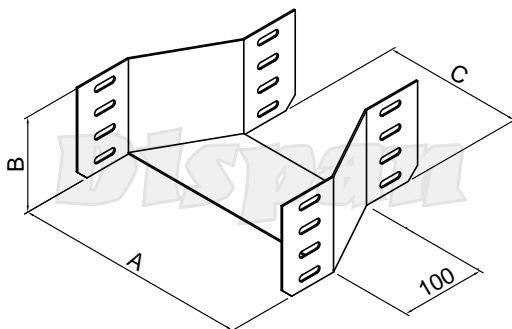

Redução à direita | Right reduction

DP: 731

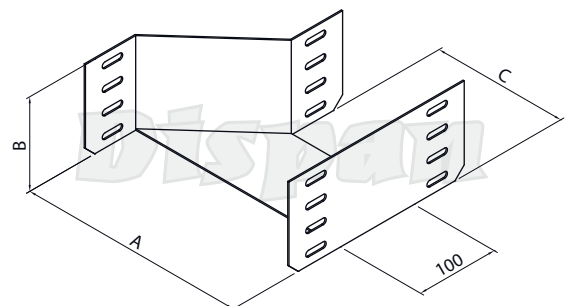

Redução à esquerda | Left reduction

DP: 732

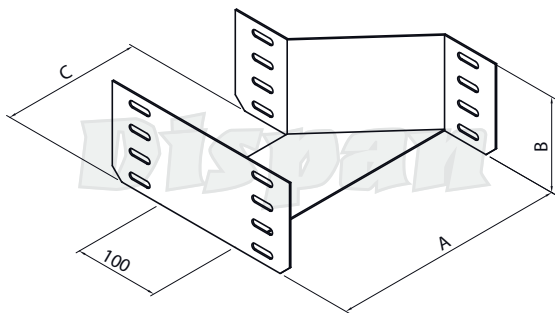

Redução de abas | Beam reduction

DP: 733

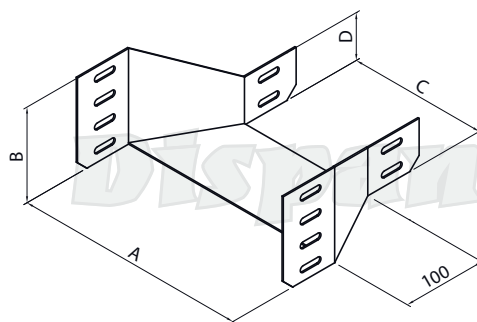

Flange p/ ligação em painel | Box connector

DP: 734

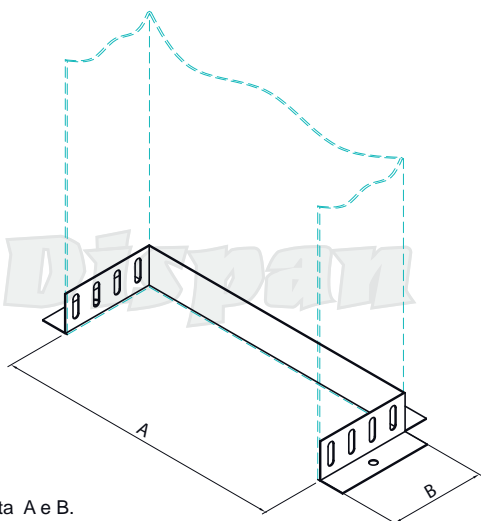

Indicar cota A e B.

Emenda interna perfurada | Telescopic slice

DP: 736

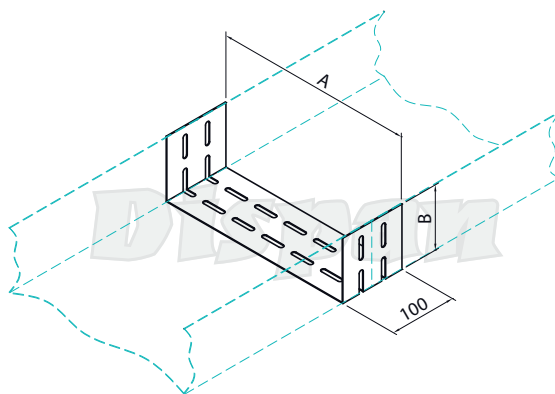

Indicar cota A e B.

Terminal liso p/ eletrocalha | End plate

DP: 737

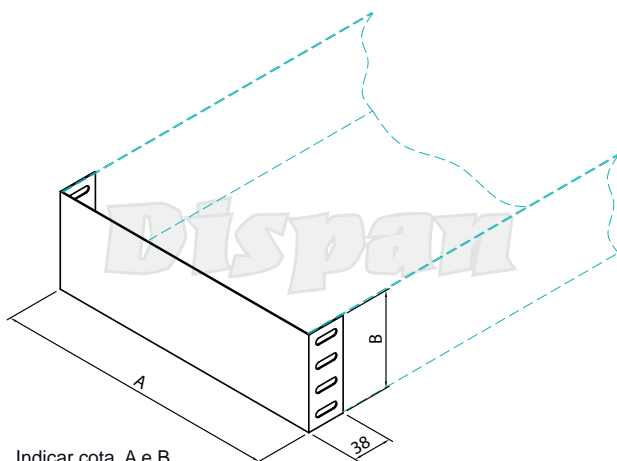

Indicar cota A e B.

Gotejador | Dropout

DP: 738

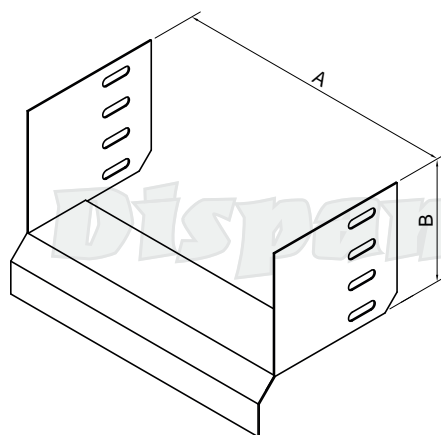

Indicar cota A e B.

Curva horizontal 90° raio curvilíneo
Horizontal blend - 90°

DP: 710C

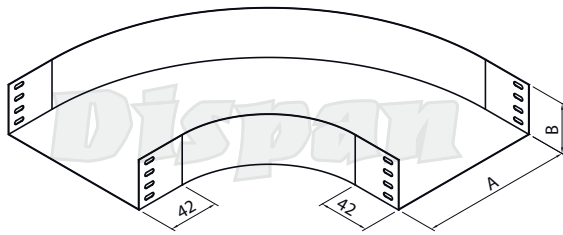

Indicar Cota A e B

Raio	C
150	192
200	242
300	342
500	542
D = A + C	

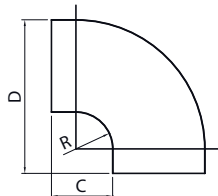

Curva horizontal 45° raio curvilíneo
Horizontal blend - 45°

DP: 711C

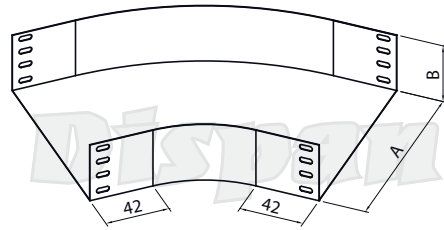

Indicar Cota A e B

Raio	C	D
150	74	178
200	88	213
300	117	284
500	176	425

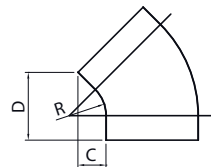

Curva vertical externa 90° raio curvilíneo
External vertical blend - 90°

DP: 712C

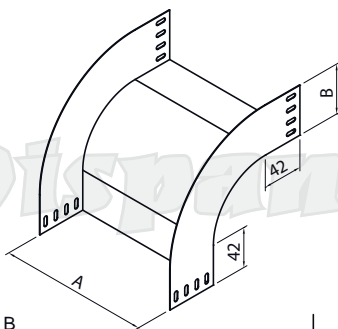

Indicar Cota A e B

Raio	C
150	192
200	242
300	342
500	542
D = C + B	

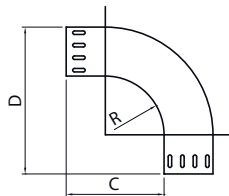

Curva vertical externa 45° raio curvilíneo
External vertical blend - 45°

DP: 713C

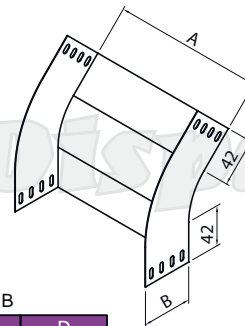

Indicar Cota A e B

Raio	C	D
150	74	178
200	88	213
300	117	284
500	176	425

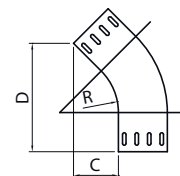

Curva vertical interna 90° raio curvilíneo
Internal vertical blend - 90°

DP: 714C

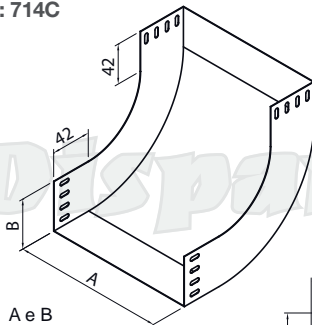

Indicar Cota A e B

Raio	C
150	192
200	242
300	342
500	542
D = C + B	

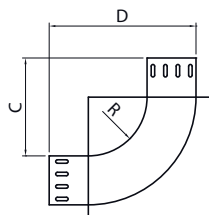

Curva vertical interna 45° raio curvilíneo
Internal vertical blend - 45°

DP: 715C

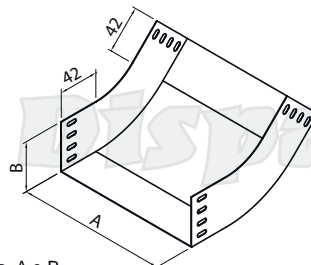

Indicar Cota A e B

Raio	C	D
150	74	178
200	88	213
300	117	284
500	176	425

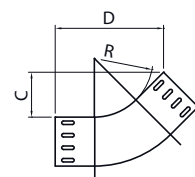

Tê horizontal 90° raio curvilíneo
Horizontal tee - 90°

DP: 716C

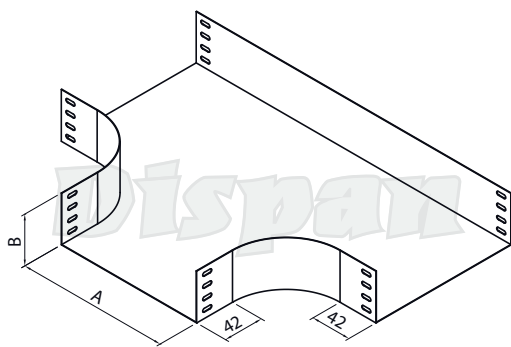

Indicar Cota A e B

Raio	C
150	192
200	242
300	342
500	542
D = 2x C + A	
E = C + A	

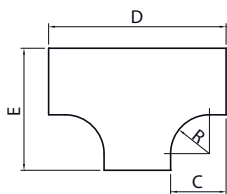

Tê vertical de descida 90° raio curvilíneo
Vertical descent tee - 90°

DP: 717C

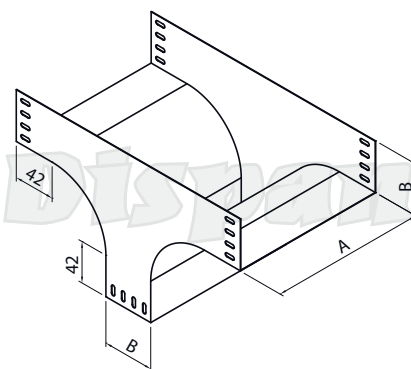

Indicar Cota A e B

Raio	C
150	192
200	242
300	342
500	542
D = 2x C + B	
E = C + B	

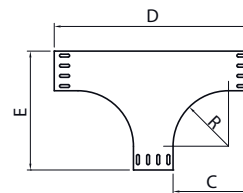

Tê vertical de subida 90° raio curvilíneo
Vertical ascent tee - 90°

DP: 718C

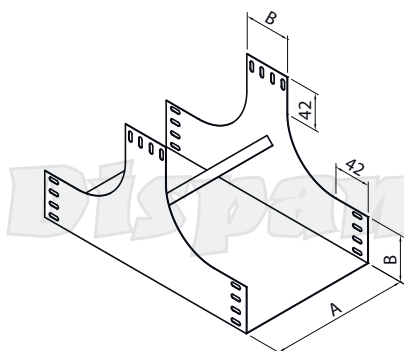

Indicar Cota A e B

Raio	C
150	192
200	242
300	342
500	542
D = 2x C + B	
E = C + B	

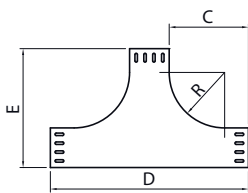

Tê vertical de descida lateral 90° raio curvilíneo
Lateral descent tee - 90°

DP: 719C

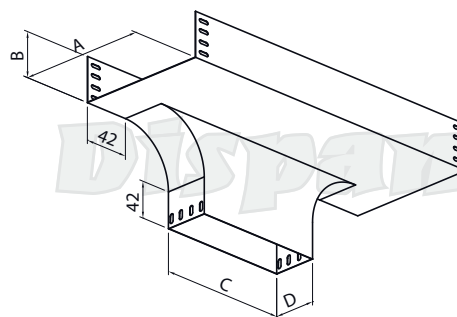

Indicar Cota A, B, C e D

Raio	E
150	192
200	242
300	342
500	542
F = 2x E + C	
G = E + B	

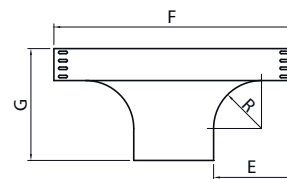

Cruzeta horizontal 90° raio curvilíneo

Horizontal cross - 90°

DP: 720C

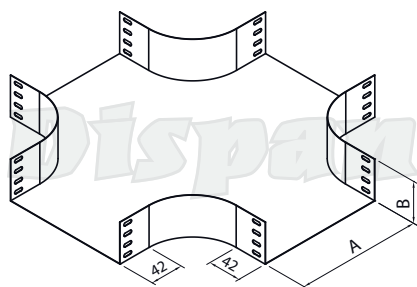

Indicar Cota A e B

Raio	C
150	192
200	242
300	342
500	542
D = 2x C + A	

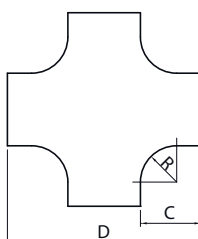

Curva de inversão 90° raio curvilíneo

Inversion bend - 90°

DP: 721C

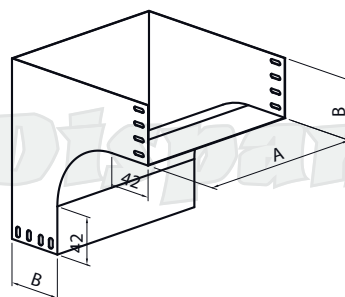

Indicar Cota A e B

Raio	C
150	192
200	242
300	342
500	542
D = C + B	

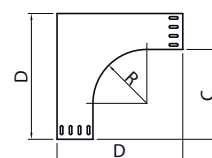

Curva com passagem reta subida 90° raio curvilíneo

90° bend with ascent straight passage

DP: 725C

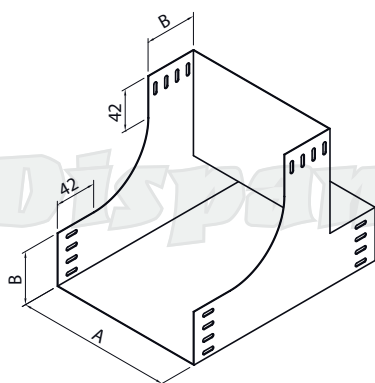

Indicar Cota A e B

Raio	C
150	192
200	242
300	342
500	542
D = C + B + 42	

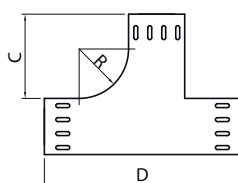

Curva com passagem reta descida 90° raio curvilíneo

90° bend with downhill straight passage

DP: 739C

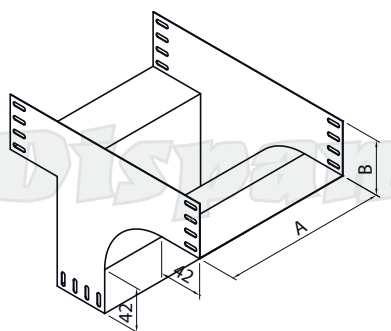

Indicar Cota A e B

Raio	C
150	192
200	242
300	342
500	542
D = C + B + 42	

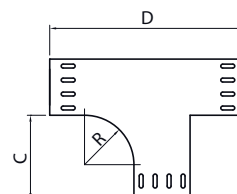



Eletrocalha estrutural c/ virola 180°

Structural cable tray w/ 180° ferrule

A eletrocalha estrutural com virola 180°, foi desenvolvida pensando em aliar, economia, resistência mecânica e segurança no manuseio.

Com estas premissas, a Dispan criou esta nova linha de encaminhamento metálico para cabeamentos, já que o momento solicita um projeto econômico alinhado á resistência.

O novo formato desta linha de eletrocalhas, atende normas nacionais e internacionais, quanto a resistência mecânica e segurança.

The structural cable tray with 180° ferrule was developed thinking about combining economy, mechanical strength and safety in handling.

With these principles in mind, Dispan has created this new line of metallic routing for cabling, as the moment calls for an economical project aligned with resistance.

The new format of this line of cable trays meets national and international standards in terms of mechanical strength and safety.

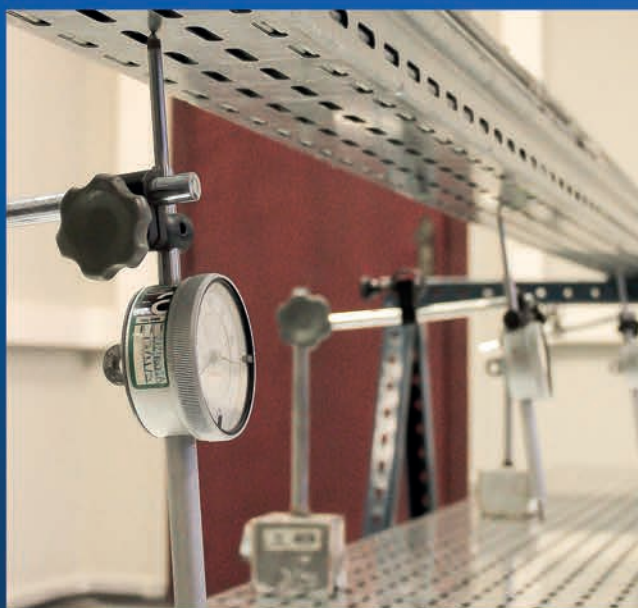
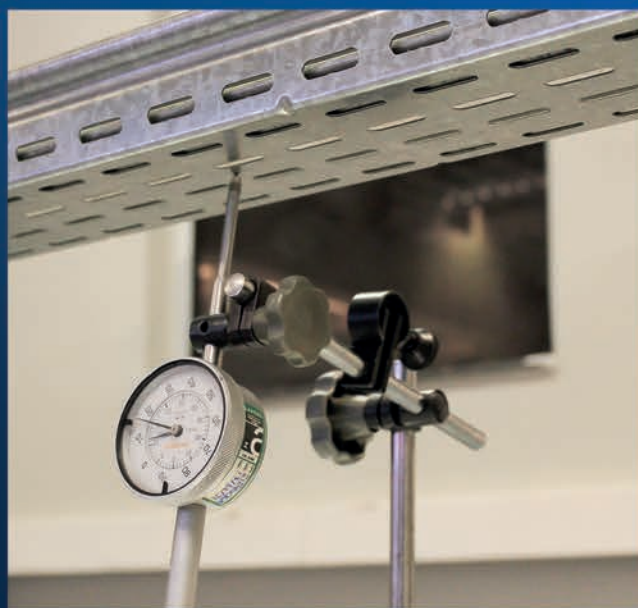

Como solicitar conexões para eletrocalhas

How to specify connections for cable tray channel type.

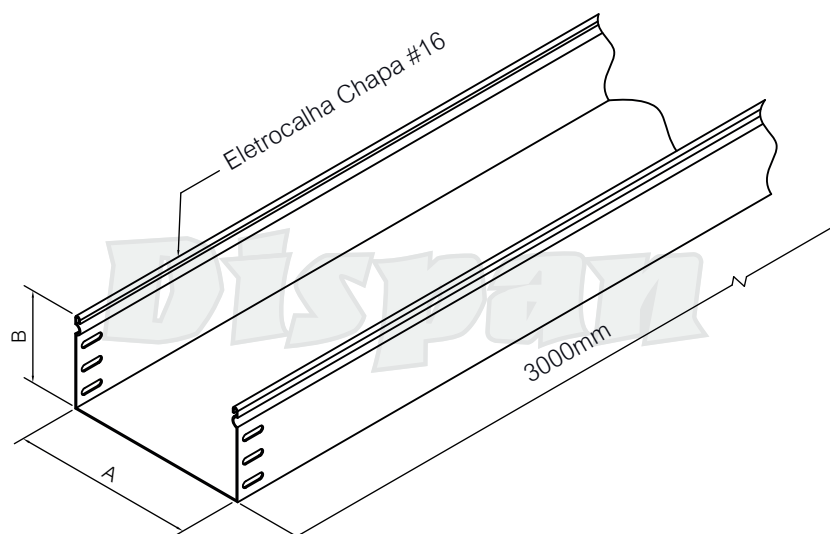

Exemplo
Example

DP701E - AC - GF - 400/100 - 16

Referência do catálogo de produtos com características básicas

Product catalog reference with basic features

Matéria prima de fabricação.

Manufacturing raw material

Acabamento.

Finish

Largura / Altura da eletrocalha

Width / height of cable tray

Chapas de construção da eletrocalha.

Cable tray construction plate

DP701E - Eletrocalha lisa estrutural c/ virola 180°
Structural cable tray single • C with ferrule 180°

Matéria prima base.

Raw material base

AC - Aço carbono

Carbon steel

Acabamento aplicado na matéria-prima em base de aço carbono.

Finish applied to the raw material in carbon steel base

GF - Galvanizado á fogo por imersão.

Hot dip galvanized

GE - Galvanizado eletrolítico

Electrolytic galvanized

PZ - Pré-zincado

Pre-zincated

NT - Natural

Natural

PT - Pintado

Painting

Largura.

Width

400 - Largura da eletrocalha desejada (De 50 a 400 mm).

400 - Width of the wanted cable tray (100 to 400 mm)

Chapas disponíveis = #16 / #18 / #20 / #22 / #24

Exemplo de descritivo técnico | Example technical description.

DP701E é Eletrocalha estrutural lisa com virola 180°, em aço carbono, galvanizado á fogo, largura de 400mm, com aba de 100mm em chapa #16.

DP701E • Structural cable tray single - C with ferrule 180°, carbon steel, hot dip galvanized, width of 400mm, with tab of 100mm in plate #16.

Nota.

Ocasionalmente podem ocorrer algumas distorções de medidas em nossas peças, por diversos fatores. Por este motivo damos uma tolerância de 5,0 mm entre as medidas mencionadas no catálogo e as peças reais.

Os furos oblongos são feitos exatamente para compensação e ajuste de eventuais diferenças.

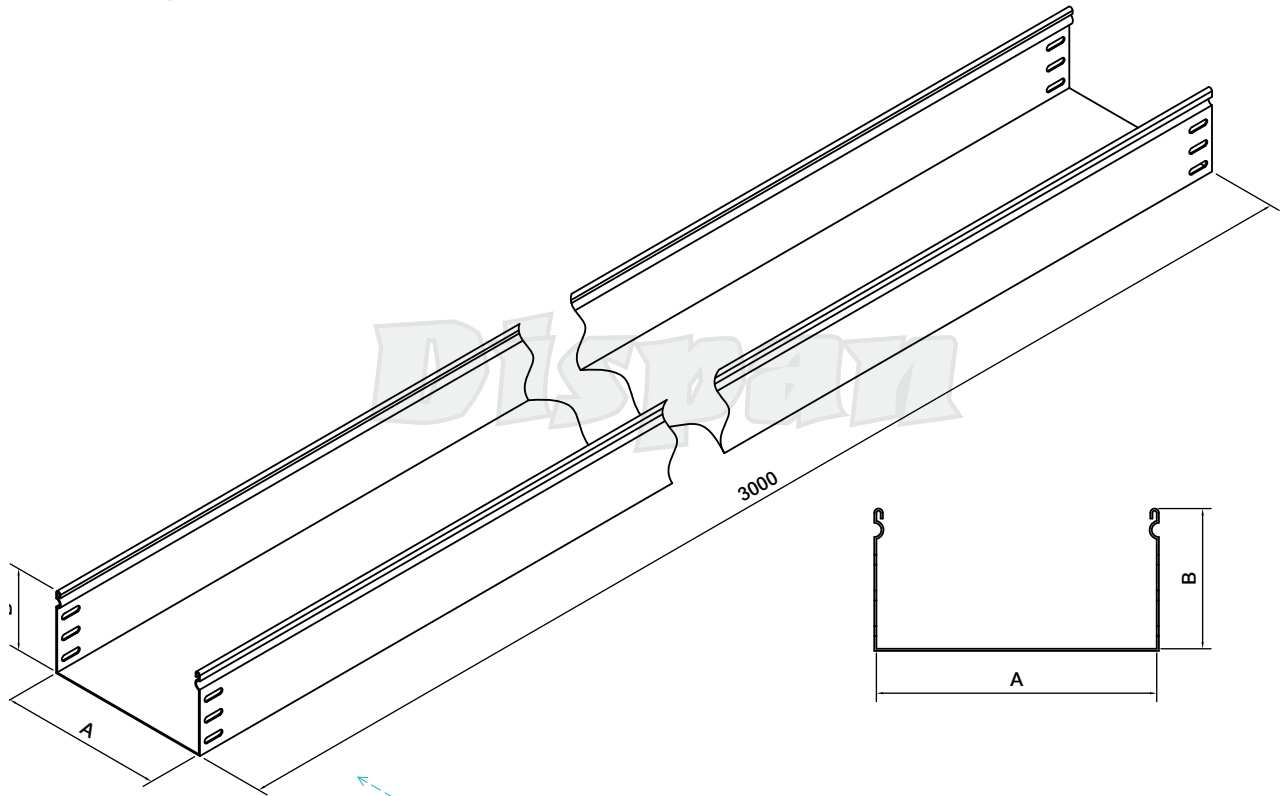

Aba de 50 mm

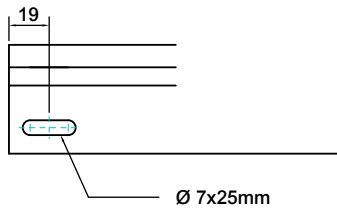

Aba de 75 mm

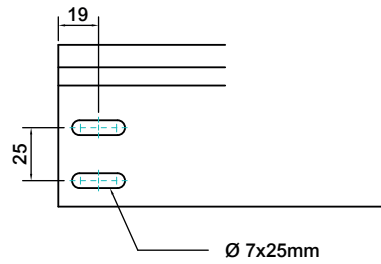

Aba de 100 mm

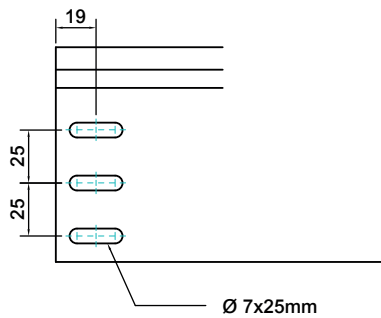

Comparativo entre DP700 e DP701E				
Largura x Aba	DP700 Ch #18		DP701E Ch #22	
	2 mts	3 mts	2 mts	3 mts
100x50 mm	65 kg.	40 kg.	70 kg.	50 kg.

Eletrocalha lisa com virola de 180° e vinco estrutural na lateral

altura da aba 50mm			
carga distribuída entre suportes em kg			
largura mm	chapa #	distância entre suportes	
		2 mt	3 mt
50	24	43	20
50	22	47	22
50	20	60	40
50	18	80	50
100	24	47	26
100	22	70	50
100	20	85	54
100	18	95	65
150	24	48	28
150	22	60	40
150	20	80	50
150	18	90	60
200	24	62	38
200	22	75	48
200	20	83	53
200	18	105	66
300	22	72	41
300	20	78	47
300	18	88	55
300	16	95	65
400	22	70	45
400	20	90	62
400	18	96	67
400	16	102	75

altura da aba 75mm			
carga distribuída entre suportes em kg			
largura mm	chapa #	distância entre suportes	
		2 mt	3 mt
75	24	56	31
75	22	52	38
75	20	68	43
75	18	75	48
100	24	65	42
100	22	74	45
100	20	80	52
100	18	87	60
150	24	68	44
150	22	76	48
150	20	83	56
150	18	91	63
200	24	70	47
200	22	80	52
200	20	87	60
200	18	95	66
300	22	80	52
300	20	87	60
300	18	95	66
300	16	102	71
400	22	83	55
400	20	90	72
400	18	98	74
400	16	106	81

altura da aba 100mm			
carga distribuída entre suportes em kg			
largura mm	chapa #	distância entre suportes	
		2 mt	3 mt
100	24	62	40
100	22	70	50
100	20	92	62
100	18	105	55
150	24	62	40
150	22	75	50
150	20	80	60
150	18	90	70
200	24	84	52
200	22	90	60
200	20	115	85
200	18	122	93
300	22	90	61
300	20	103	72
300	18	110	90
300	16	115	81
400	22	82	53
400	20	105	80
400	18	116	87
400	16	125	93

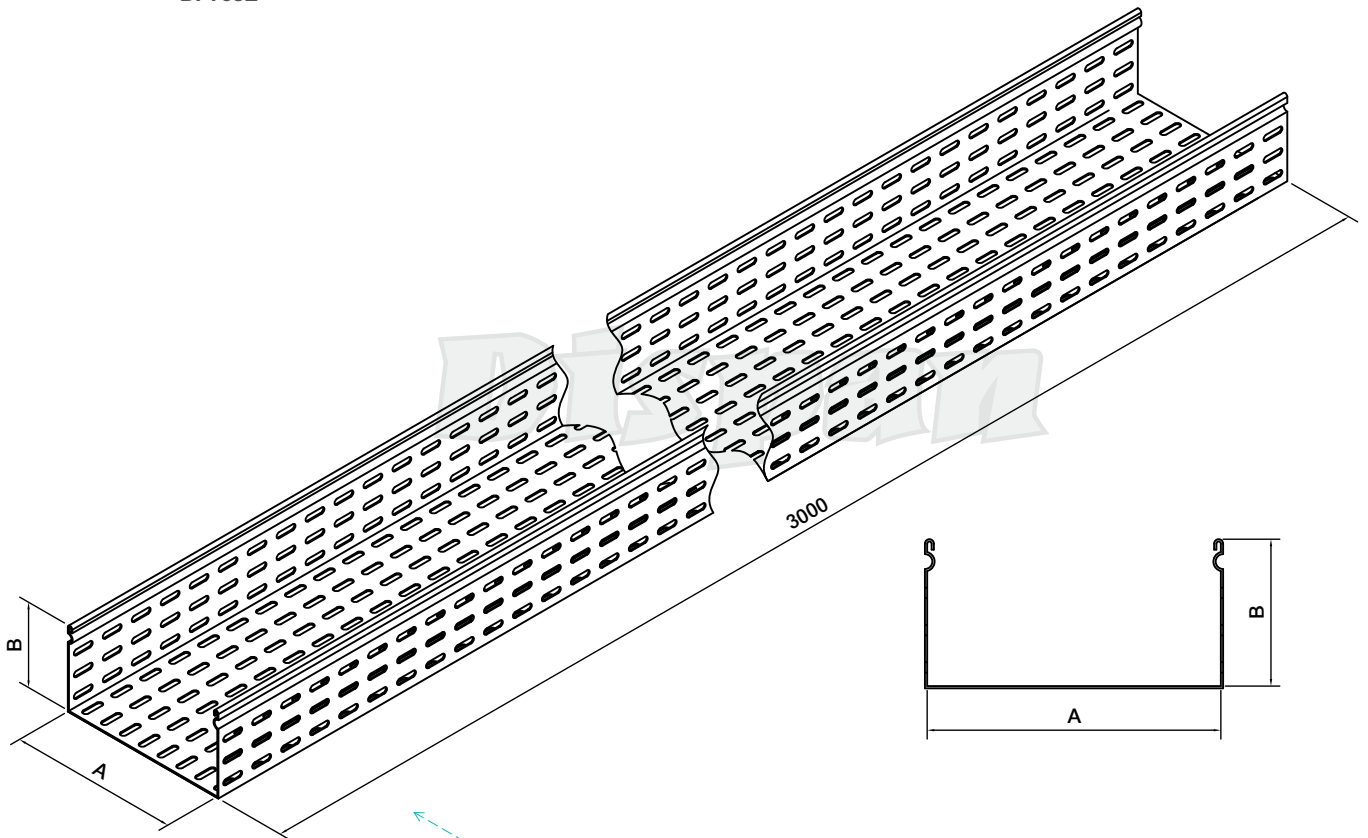

Aba de 50 mm

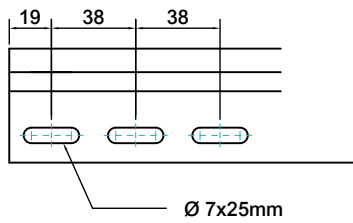

Aba de 75 mm

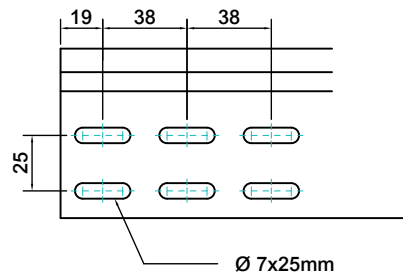

Aba de 100 mm

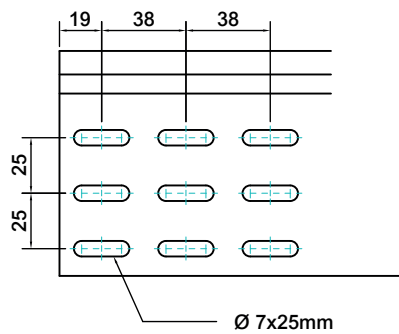

Comparativo entre DP702 e DP702E				
Largura x Aba	DP700 Ch #18		DP701E Ch #22	
	2 mts	3 mts	2 mts	3 mts
200x100 mm	63 kg.	32 kg.	90 kg.	60 kg.

Eletrocalha perforada com virola de 180° e vinco estrutural na lateral

altura da aba 50mm			
carga distribuída entre suportes em kg			
largura mm	chapa #	distância entre suportes	
		2 mt	3 mt
50	24	40	18
50	22	42	20
50	20	52	36
50	18	75	45
100	24	44	20
100	22	63	35
100	20	78	49
100	18	89	58
150	24	44	23
150	22	55	34
150	20	70	43
150	18	81	52
200	24	57	32
200	22	69	44
200	20	79	48
200	18	98	61
300	22	67	37
300	20	74	43
300	18	82	50
300	16	90	60
400	22	68	40
400	20	86	60
400	18	92	62
400	16	99	71

altura da aba 75mm			
carga distribuída entre suportes em kg			
largura mm	chapa #	distância entre suportes	
		2 mt	3 mt
75	24	52	28
75	22	58	34
75	20	64	37
75	18	70	42
100	24	61	36
100	22	68	38
100	20	74	47
100	18	81	54
150	24	64	38
150	22	71	41
150	20	77	50
150	18	86	57
200	24	64	42
200	22	73	46
200	20	80	52
200	18	88	59
300	22	73	46
300	20	82	63
300	18	88	60
300	16	96	65
400	22	79	51
400	20	84	68
400	18	94	70
400	16	101	77

altura da aba 100mm			
carga distribuída entre suportes em kg			
largura mm	chapa #	distância entre suportes	
		2 mt	3 mt
100	24	58	36
100	22	64	44
100	20	87	55
100	18	99	47
150	24	58	32
150	22	70	43
150	20	75	54
150	18	83	63
200	24	78	47
200	22	84	53
200	20	107	76
200	18	113	85
300	22	83	54
300	20	96	65
300	18	102	81
300	16	106	83
400	22	75	45
400	20	97	72
400	18	108	80
400	16	117	86

Como solicitar conexões para eletrocalhas

How to specify connections for cable tray channel type.

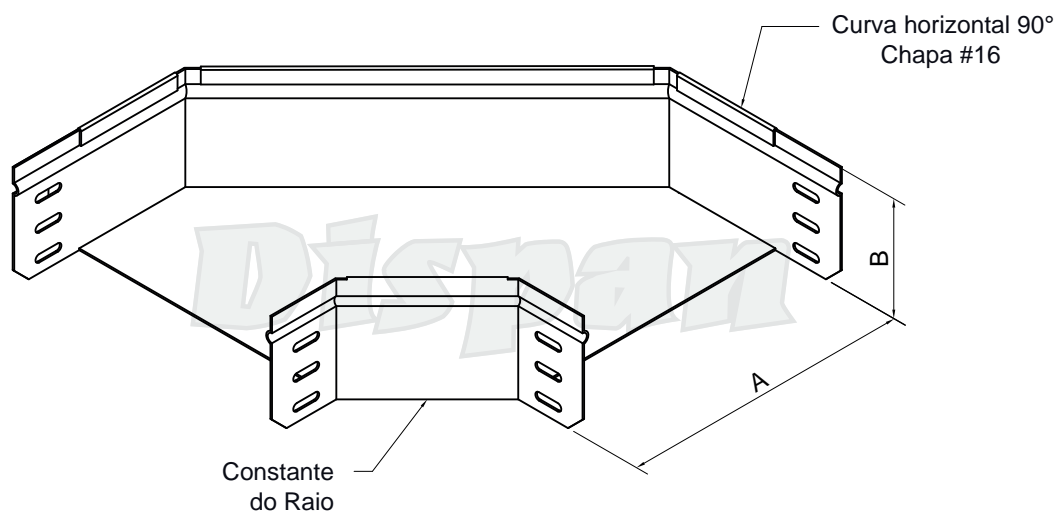

Exemplo Example

DP710E / 701E - AC - GF - 400/100 - 16 - R150

Referência do catálogo de produtos com características básicas
Product catalog reference with basic features
<https://docs.google.com/spreadsheets/d/18LoZr4w71SKFroqWA7mKCT-MKRIRh5OyT/edit#gid=145725826>

Modelo da eletrocalha.
Cable tray model

Matéria prima de fabricação.
Manufacturing raw material

Acabamento.
Finish

Largura / Altura da eletrocalha
Width / height of cable tray

Raio 150, 200
300, 500
Radius 150, 200
300, 500

Chapas de construção da eletrocalha.
Cable tray construction plate

DP710E Curva horizontal 90° c/ virola prensada 180°
Horizontal bend 90° with ferrule pressed 180°

Matéria prima base.
Raw material base
AC - Aço carbono
Carbon steel

Acabamento aplicado na matéria-prima em base de aço carbono.
Finish applied to the raw material in carbon steel base

Largura.
Width

400 - Largura da eletrocalha desejada (De 50 a 400 mm).
400 - Width of the wanted cable tray (100 to 400 mm)

GF - Galvanizado á fogo por imersão.

Hot dip galvanized

GE - Galvanizado eletrolítico

Electrolytic galvanized

PZ - Pré-zincado

Pre-zincated

NT - Natural

Natural

PT - Pintado

Painting

Chapas disponíveis = #16 / #18 / #20 / #22 / #24

*Para solicitação da tampa, colocar o código + a letra "T".
Exemplo = DP710ET

Exemplo de descritivo técnico | Example technical description.

DP701E • Curva horizontal 90° para eletrocalha estrutural lisa com virola 180°, em aço carbono, galvanizado à fogo, largura de 400mm, com aba de 100mm em chapa #16, raio de 150 mm, segmentada.

DP701E • Horizontal bend 90° for structural cable tray single - C with ferrule 180°, carbon steel, hot dip galvanized, width of 400mm, with tab of 100mm in plate #16, radius of 150mm, segmented.

Nota.

Ocasionalmente podem ocorrer algumas distorções de medidas em nossas peças, por diversos fatores. Por este motivo damos uma tolerância de 5,0 mm entre as medidas mencionadas no catálogo e as peças reais. Os furos oblongos são feitos exatamente para compensação e ajuste de eventuais diferenças.

Curva horizontal 90° raio segmentado
Horizontal bend 90°

DP: 710E

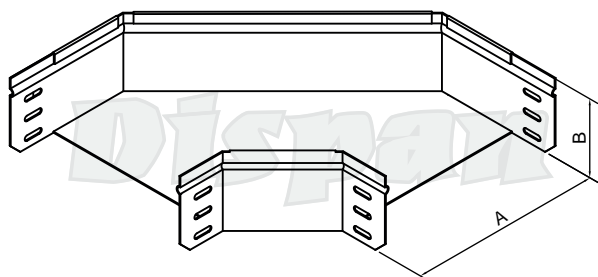

Curva horizontal 45° raio segmentado
Horizontal bend 45°

DP: 711E

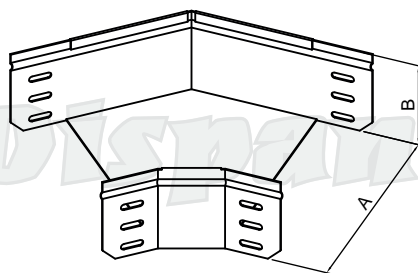

Curva vertical externa 90° raio segmentado | External vertical bend 90°

DP: 712E

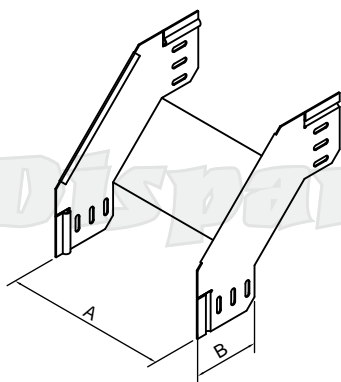

Curva vertical externa 45° raio segmentado | External vertical bend 45°

DP: 713E

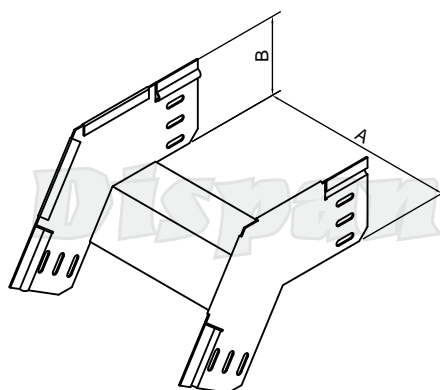

Curva vertical interna 90° raio segmentado | Internal vertical bend 90°

DP: 714E

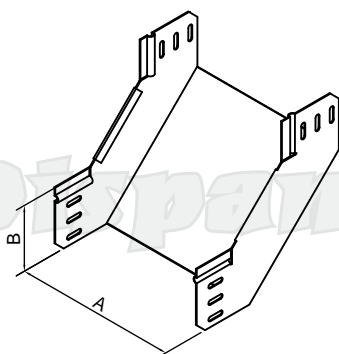

Curva vertical interna 45° raio segmentado | Internal vertical bend 45°

DP: 715E

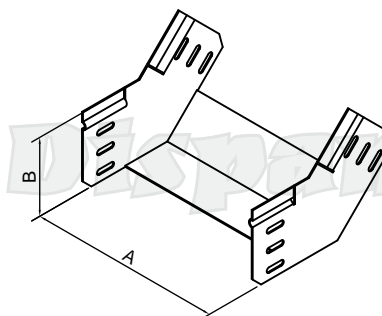

Te horizontal 90° raio segmentado
Horizontal tee 90°

DP: 716E

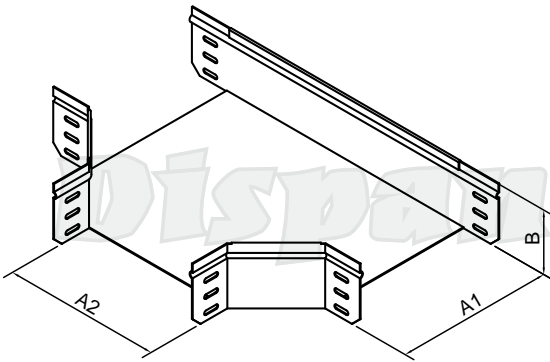

Te vertical de descida 90° raio segmentado | Vertical descent tee 90°

DP: 717E

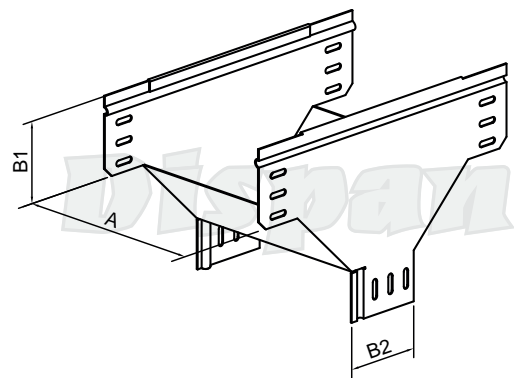

Te vertical de subida 90° raio segmentado | Vertical ascent tee 90°

DP: 718E

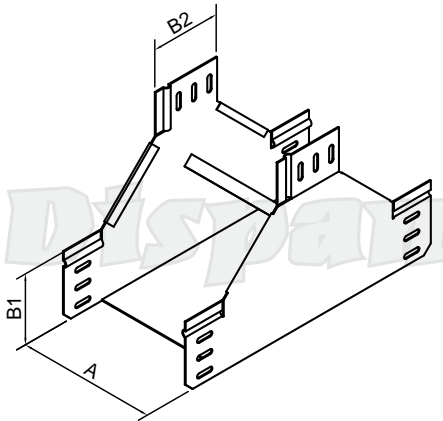

Te vertical de descida lateral 90° raio segmentado | Lateral descent tee 90°

DP: 719E

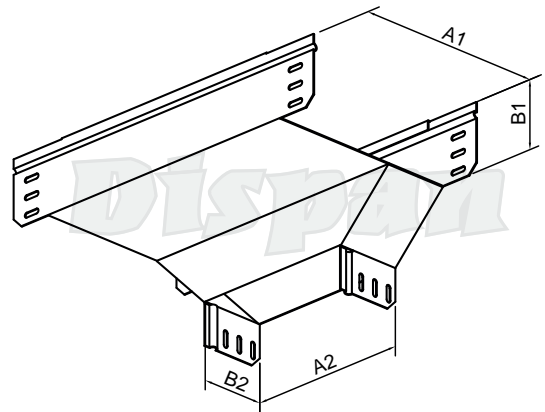

Cruzeta horizontal 90° raio segmentado
Horizontal cross 90°

DP: 720E

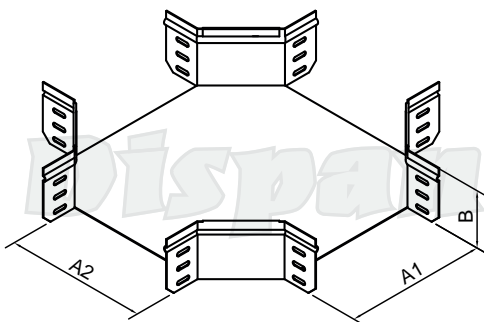

Curva de inversão 90° raio segmentado
Inversion bend 90°

DP: 721E

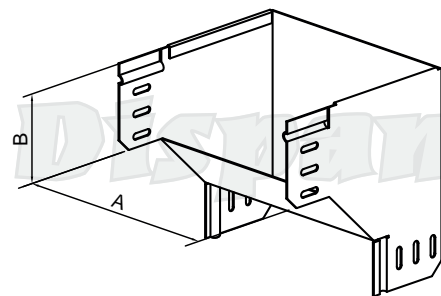

Te reto 90°
Straight tee 90°

DP: 722E

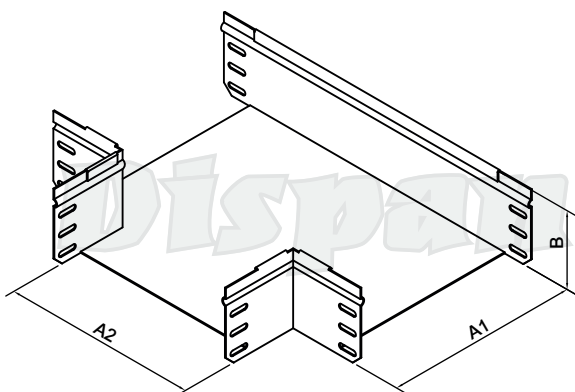

Cotovelo reto 90°
Elbow 90°

DP: 723E

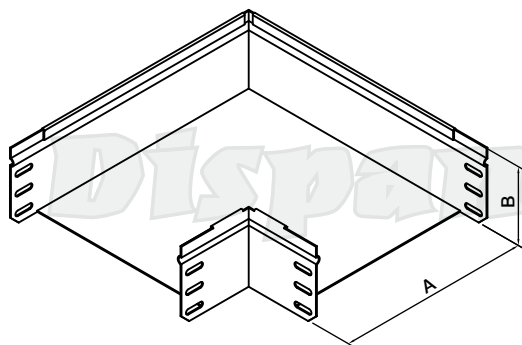

Cruzeta reta 90°
Straight cross 90°

DP: 724E

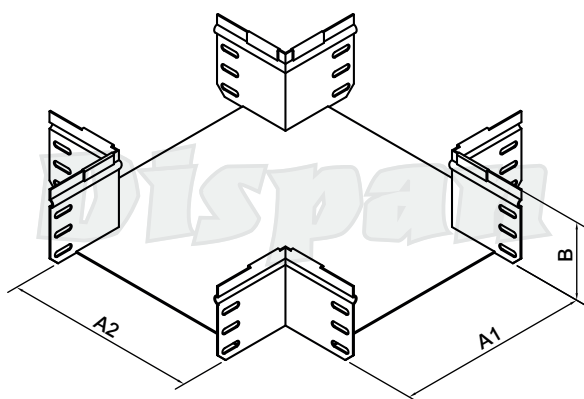

Curva com passagem reta subida 90° raio segmentado | 90° Bend with ascent straight passage

DP: 725E

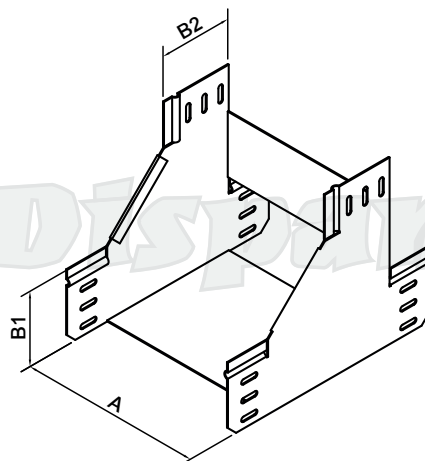

Segmento de montagem - DP760
Coupling enter connections.

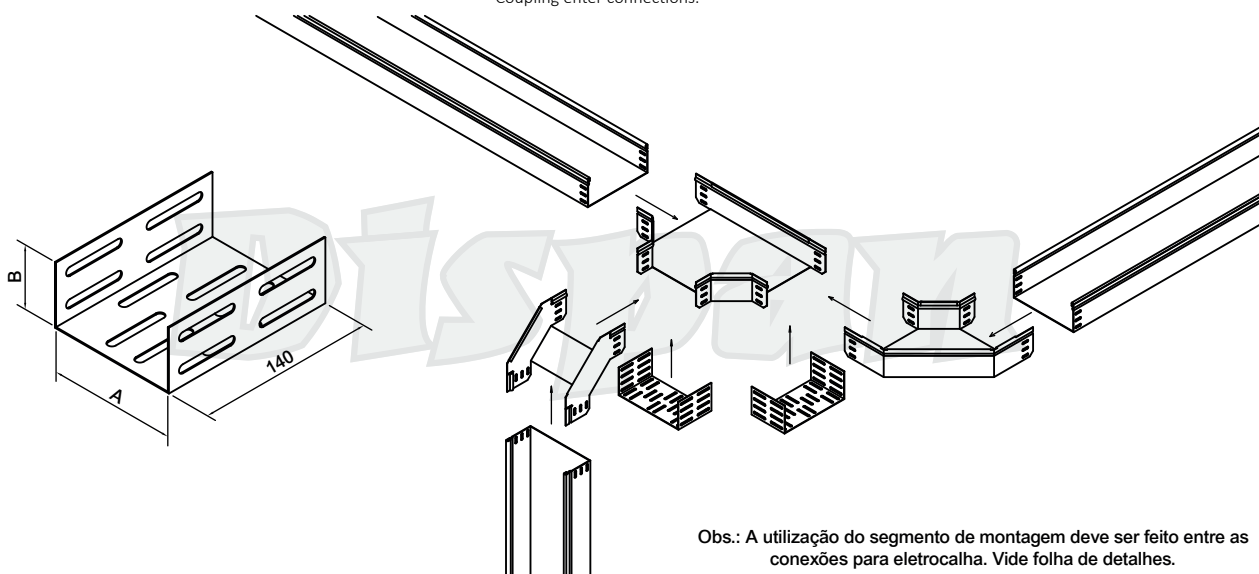

Obs.: A utilização do segmento de montagem deve ser feito entre as conexões para eletrocalha. Vide folha de detalhes.

Junção à direita 45°
Right junction 45°

DP: 726E

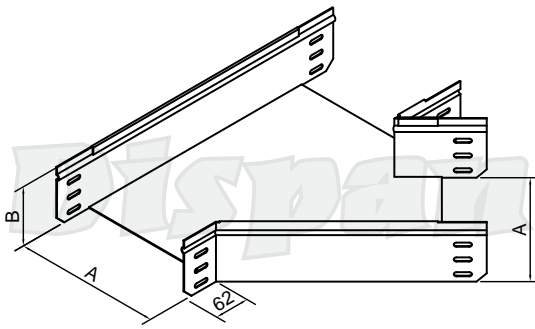

Junção à esquerda 45°
Left junction 45°

DP: 727E

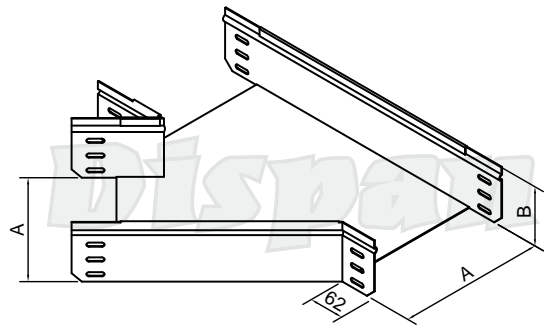

Curva com passagem reta descida 90° raio segmentado | Bend with descent straight passage

DP: 739E

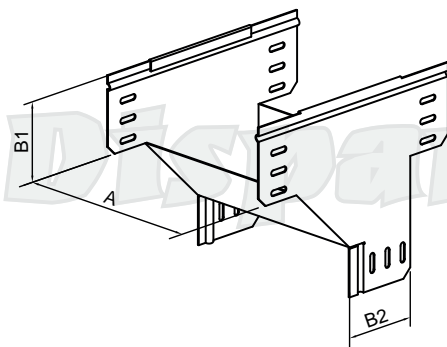

Presilha para tampa em eletrocalha
Cover plate beam clamp

DP: 761

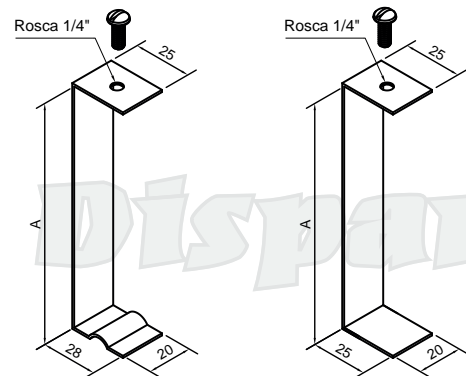

Presilha p/ eletrocalha perfurada.

Presilha p/ eletrocalha lisa.

Desvio horizontal à esquerda 45°
Left deviation 45°

DP: 728E

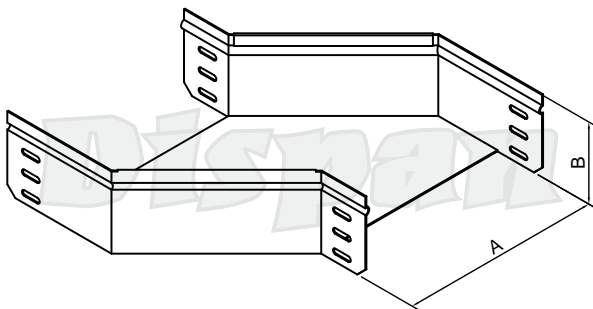

Desvio horizontal à direita 45°
Right deviation 45°

DP: 729E

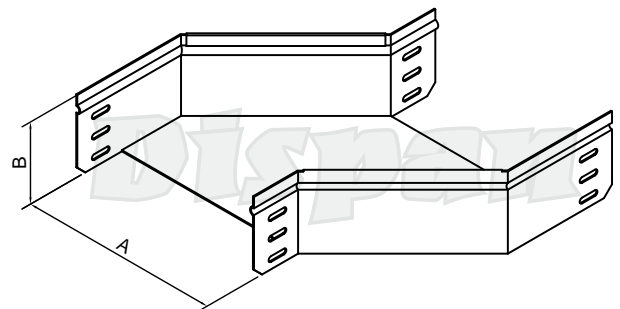

Redução concêntrica

Concentric reduction

DP: 730E

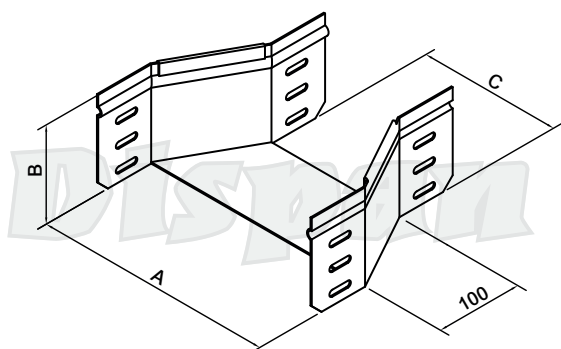

Redução à direita

Right reduction

DP: 731E

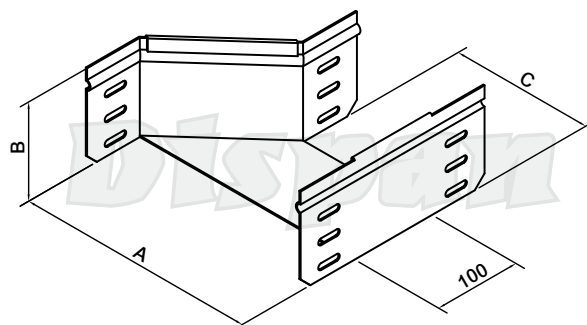

Redução à esquerda

Left reduction

DP: 732E

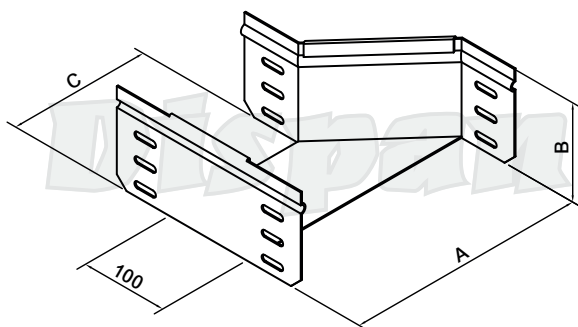

Redução de abas

Beam reduction

DP: 733E

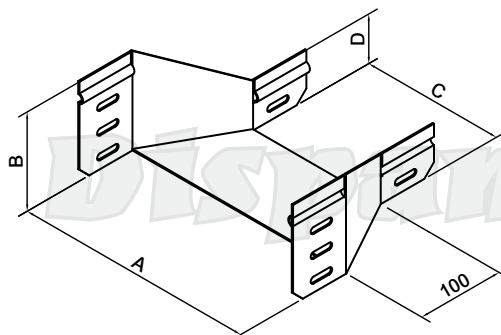

Flange para ligação em painel

Box connector

DP: 734

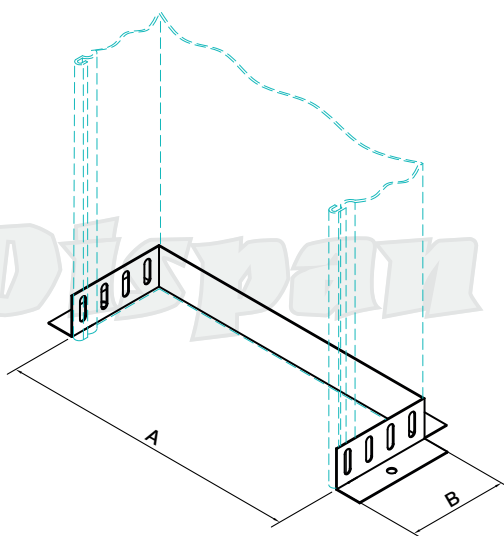

Indicar cota A e B.

Emenda interna perfurada

Telescopic splice

DP: 736

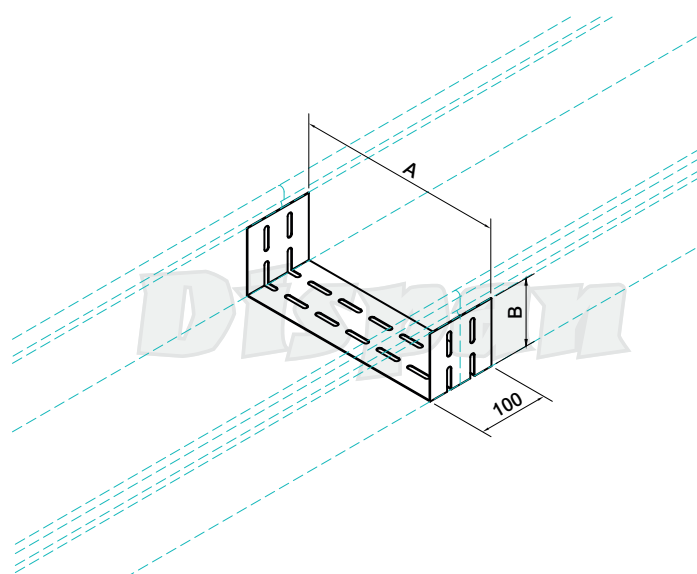

Indicar cota A e B.

Tala para eletrocalha
perfurada | Single splice pate

DP: 740

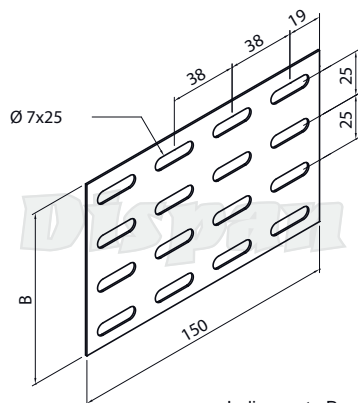

Indicar cota B.

Tala curta perfurada

DP: 741

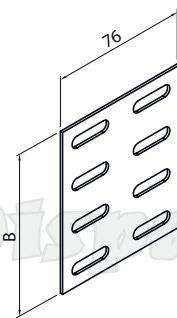

Indicar cota B.

Suporte horizontal

Horizontal hanger

DP: 742

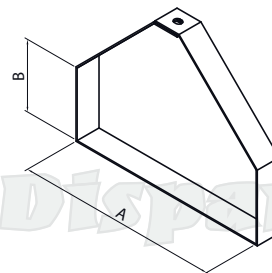

Obs.: De acordo com as dimensões das eletrocalhas.

Suporte vertical

Vertical hanger

DP: 743

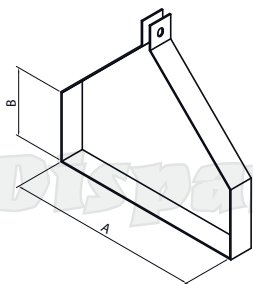

Suporte duplo

Double support

DP: 744

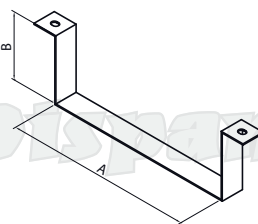

Suporte reforçado

Reinforced support

DP: 745

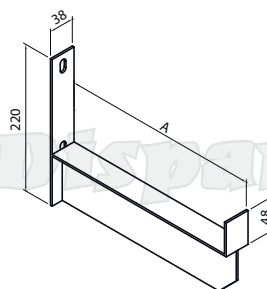

Referência: DP 745

Suporte reforçado.

Tabela de cargas.

A mm	Carga Máxima Kg.
50	120
100	80
150	70
200	50
300	20
400	15

Obs.: De acordo com as dimensões das eletrocalhas.

*Obs.: Largura máxima de A = 400 mm.

Esquema de montagem p/ tala

Typical applications

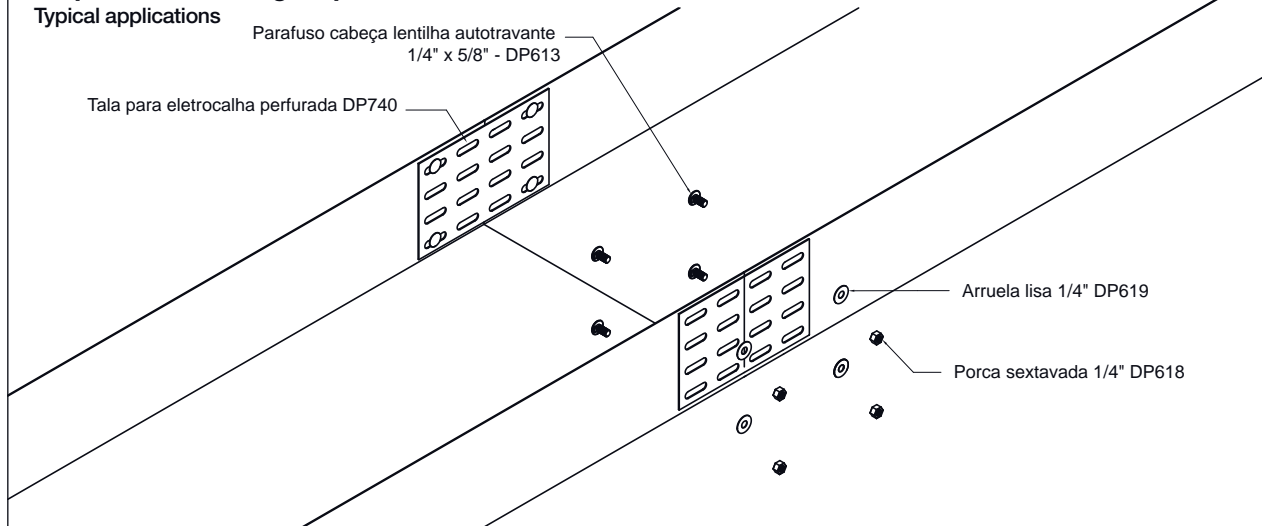

Carga uniformemente distribuída em mão francesa

Uniform ly distribuid loads on bracket

Carga distribuída

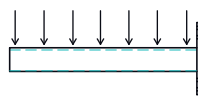

Carga distribuída

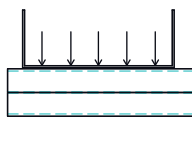

Carga distribuída

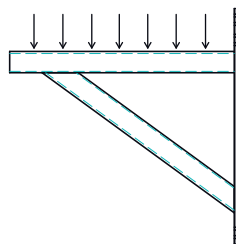

Carga distribuída

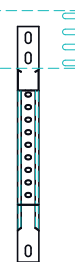
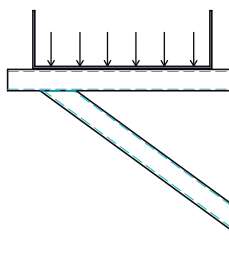

Mão francesa simples | Single bracket

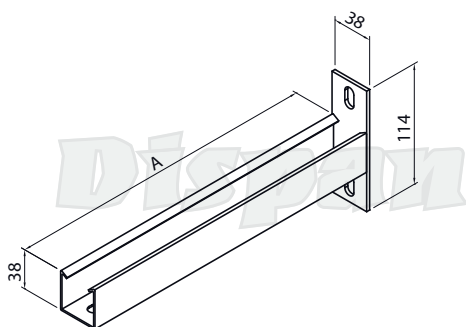

Indicar cota A.

Referência: DP 746	
Mão francesa simples comercial.	
Tabela de cargas.	
A mm	Carga Máxima Kg.
100	150
150	150
200	120
250	100
300	70
400	50
500	40
600	40
700	35
800	30

Referência: DP 746 - I	
Mão francesa simples industrial.	
Tabela de cargas.	
A mm	Carga Máxima Kg.
100	220
150	200
200	160
250	150
300	140
400	100
500	80
600	60
700	45
800	35

Mão francesa dupla | Double bracket

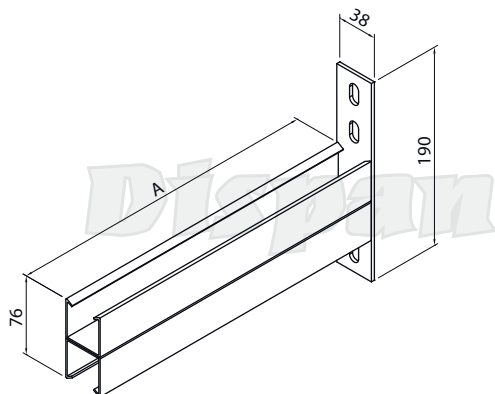

Indicar cota A.

Referência: DP 747	
Mão francesa dupla comercial.	
Tabela de cargas.	
A mm	Carga máxima Kg.
100	180
150	180
200	150
250	150
300	100
400	70
500	60
600	50
700	40
800	35
900	35
1000	30

Referência: DP 747 - I	
Mão francesa dupla industrial.	
Tabela de cargas.	
A mm	Carga máxima Kg.
100	350
150	350
200	350
250	350
300	310
400	270
500	240
600	200
700	170
800	140
900	100
1000	70

Mão francesa reforçada | Reinforced bracket

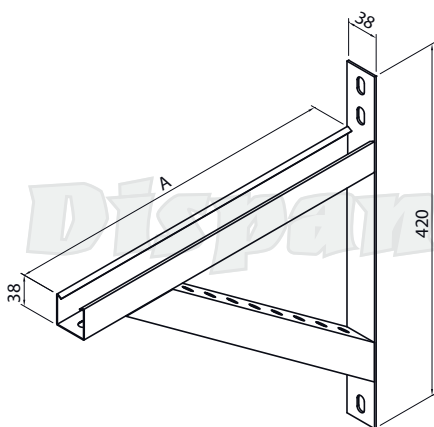

Indicar cota A

Referência: DP 748	
Mão francesa reforçada comercial.	
Tabela de cargas.	
A mm	Carga Máxima Kg.
100	380
150	380
200	380
250	380
300	350
400	350
500	320
600	320
700	270
800	240
900	200
1000	170
1200	150

Referência: DP 748 - I	
Mão francesa reforçada industrial.	
Tabela de cargas.	
A mm	Carga Máxima Kg.
100	450
150	450
200	450
250	400
300	400
400	400
500	400
600	380
700	380
800	380
900	350
1000	350
1200	330

Acoplamento de eletrocalha p/ perfilado 38x38 mm

Upper outlet - cable tray 38x38 mm

DP: 749

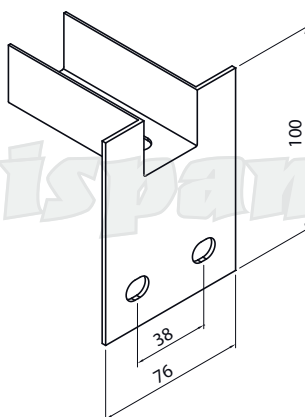

Acoplamento de eletrocalha p/ perfilado 38x76 mm

Upper outlet - cable tray 38x76 mm

DP: 750

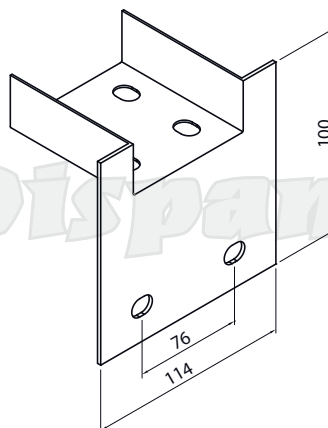

Saída horizontal p/ eletroduto

Upper or lower horizontal outlet

DP: 751

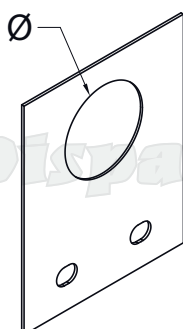

Referência	Ø
751 - 1	1/2"
751 - 2	3/4"
751 - 3	1"
751 - 4	1.1/4"
751 - 5	1.1/2"
751 - 6	2"
751 - 7	2.1/2"
751 - 8	3"
751 - 9	3.1/2"
751 - 10	4"

Indicar o Ø.

Saída vertical p/ eletroduto

Upper or lower vertical outlet

DP: 752

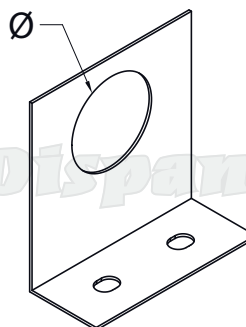

Referência	Ø
751 - 1	1/2"
751 - 2	3/4"
751 - 3	1"
751 - 4	1.1/4"
751 - 5	1.1/2"
751 - 6	2"
751 - 7	2.1/2"
751 - 8	3"
751 - 9	3.1/2"
751 - 10	4"

Indicar o Ø.

Terminal c/ saída p/ eletroduto
Bottom outlet

DP: 753

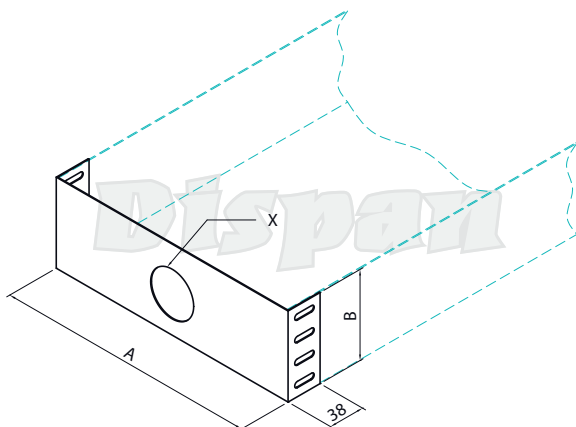

Indicar cota A, B e Ø X.

Terminal c/ saída p/ perfilado 38x38
Channel outlet

DP: 765

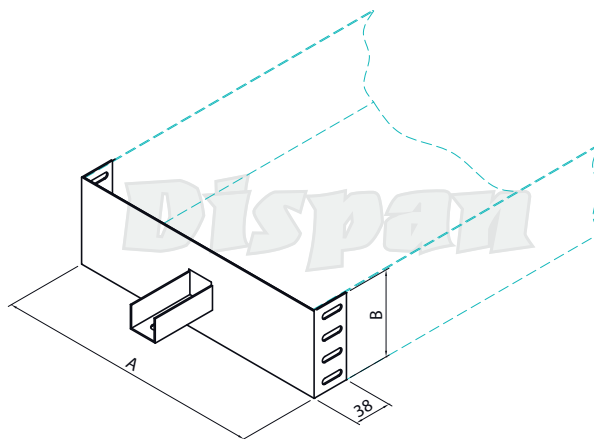

Indicar cota A e B.

Terminal c/ saída p/ perfilado 38x76
Channel outlet

DP: 766

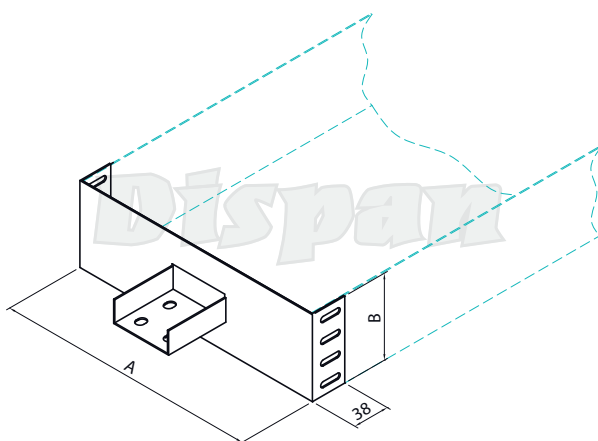

Indicar cota A e B.

Junção articulada p/ eletrocalha
Flexible splice for cable trays

DP: 755

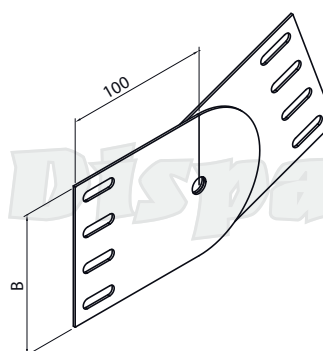

Indicar cota B.

Junção redutora excêntrica p/ eletrocalha | Reducing junction

DP: 757

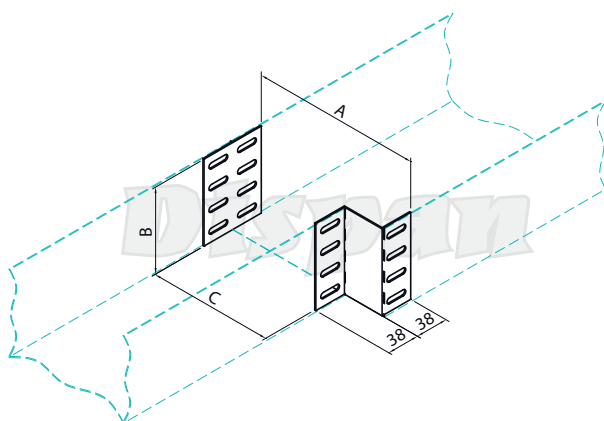

Indicar cota A, B e C.

Junção redutora concêntrica p/ eletrocalha | Concentric reducing

DP: 758

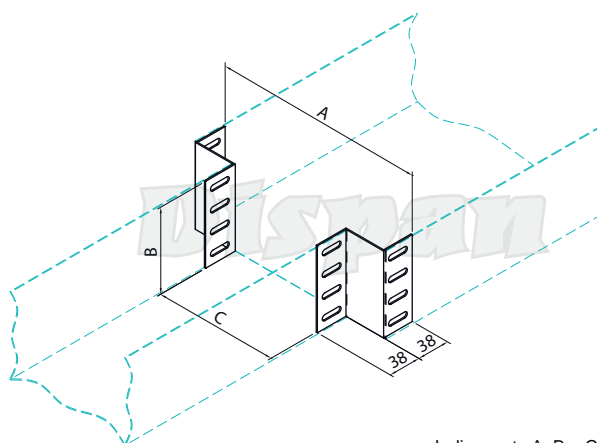

Indicar cota A, B e C.

Cinta p/ fechamento de tampa p/ eletrocalha | Supportand and belt for cable trays channel type

DP: 763-C

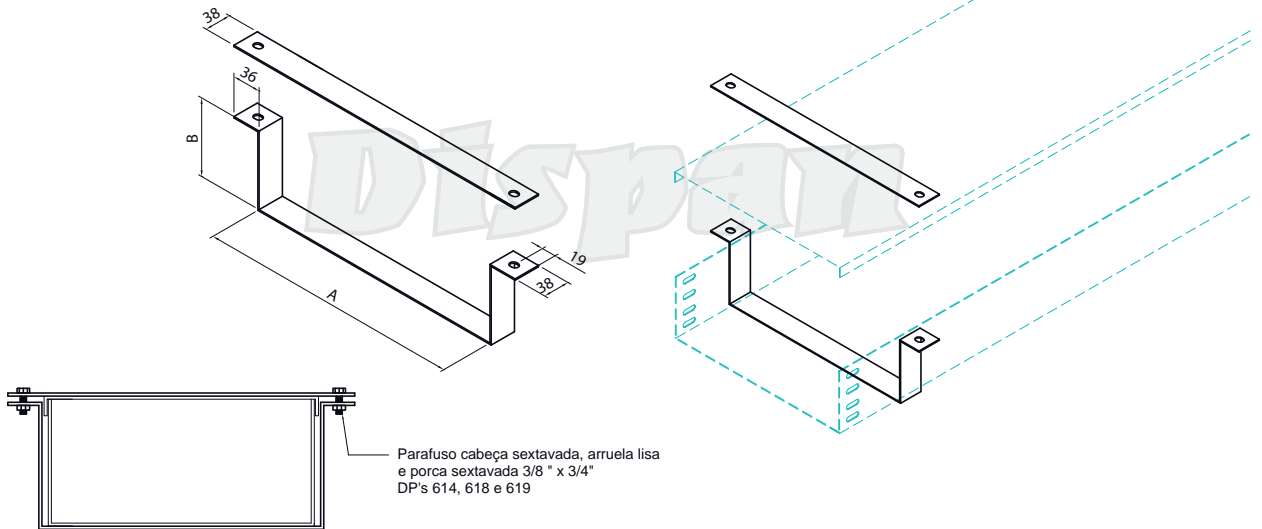

Guarnição de borracha p/ eletrocalha
Rubber protection for cable tray channel type

DP: 762

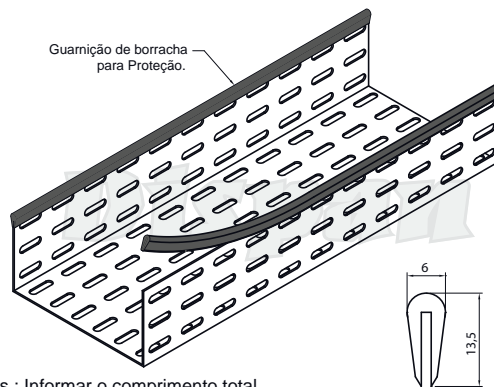

Obs.: Informar o comprimento total.
*Venda a parte.

Mata junta p/ tampa de eletrocalha
Closing to anglo cover

DP: 859

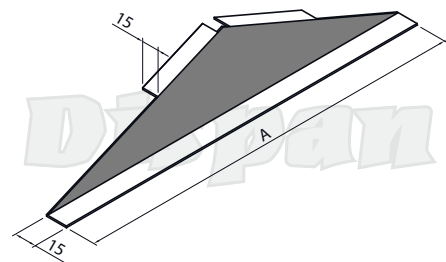

Obs.: As mata juntas são necessárias todas as vezes que houver um encontro de conexões e trechos retos de eletrocalhas utilizando tampa 2 águas. Largura mínima de 200 mm

Esquema de montagem para mata junta para eletrocalha

Typical applications of the closing to anglo cover

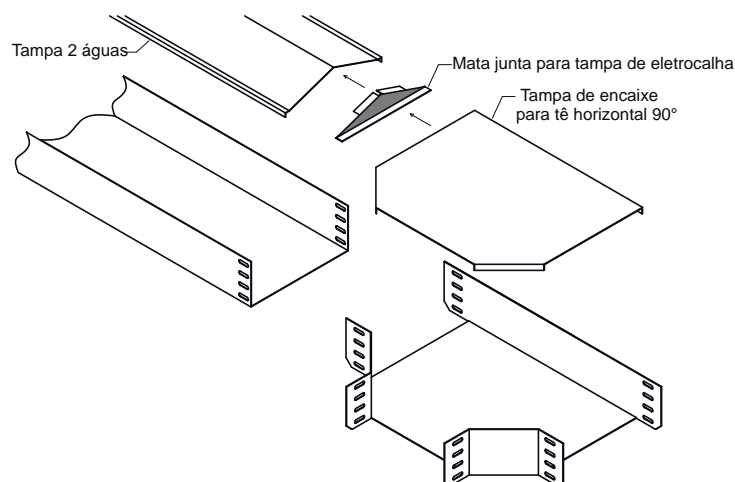

Junção horizontal articulada para eletrocalha | Horizontal articulated junction

DP: 764

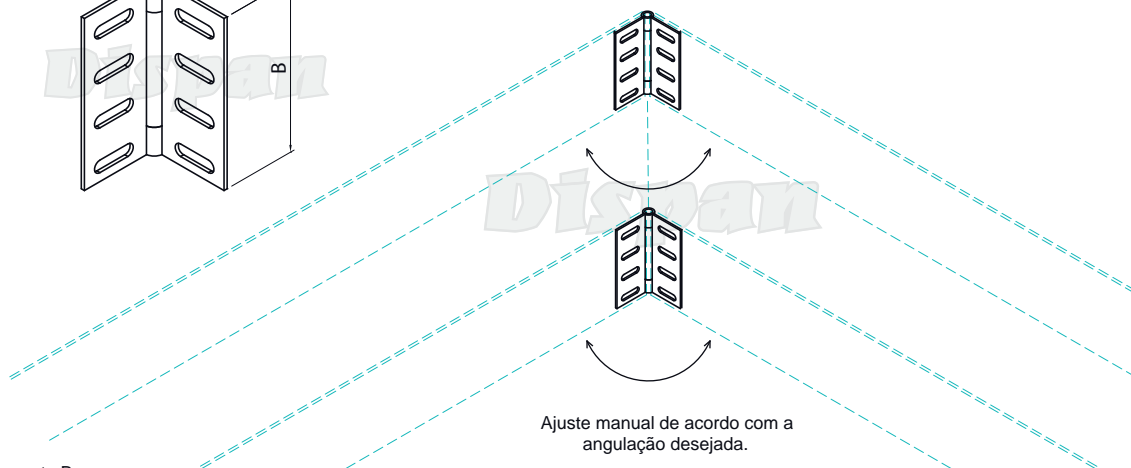
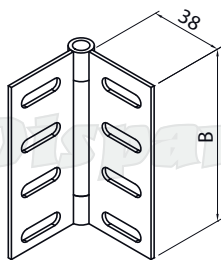

Indicar cota B.

Junção vertical de subida | Vertical rise junction

DP: 775

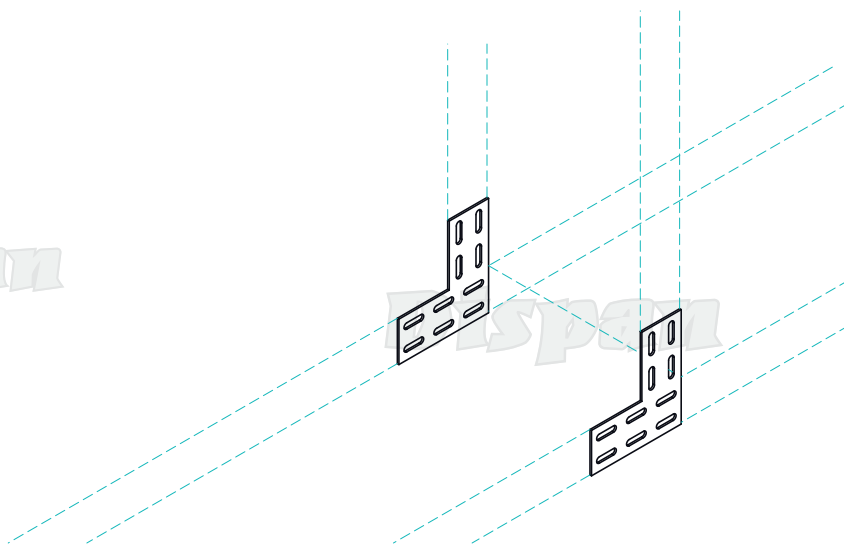
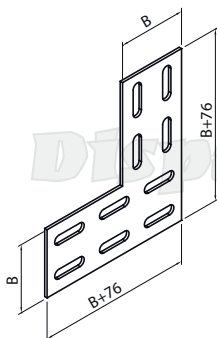

Junção redutora excêntrica ajustável | Reductive eccentric junction adjustable

DP: 776

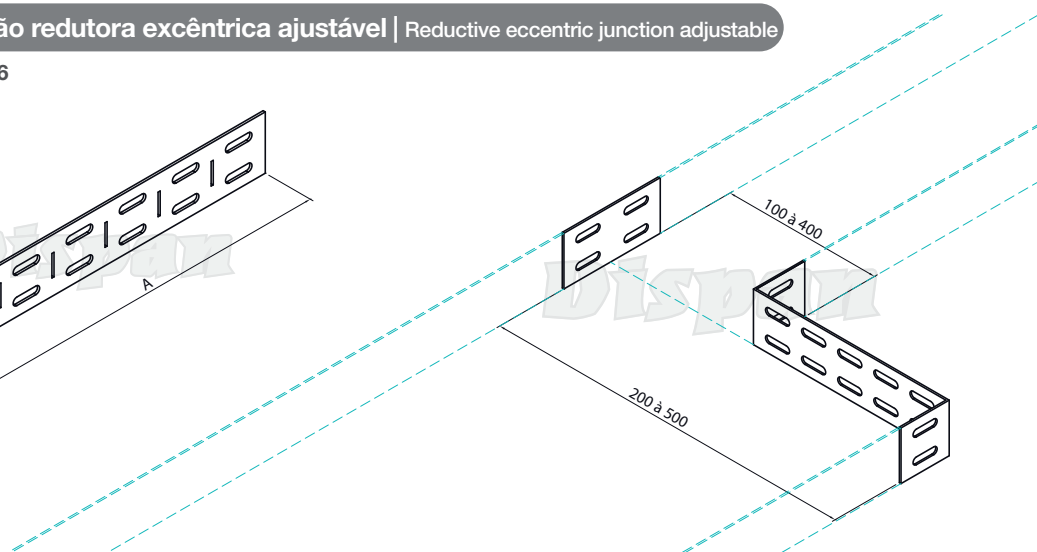
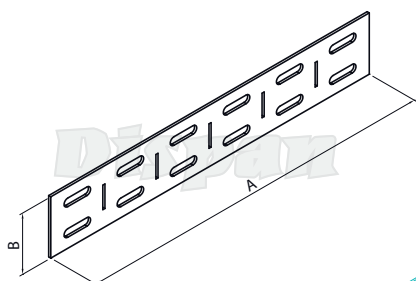

Perfilados

Steel profiled

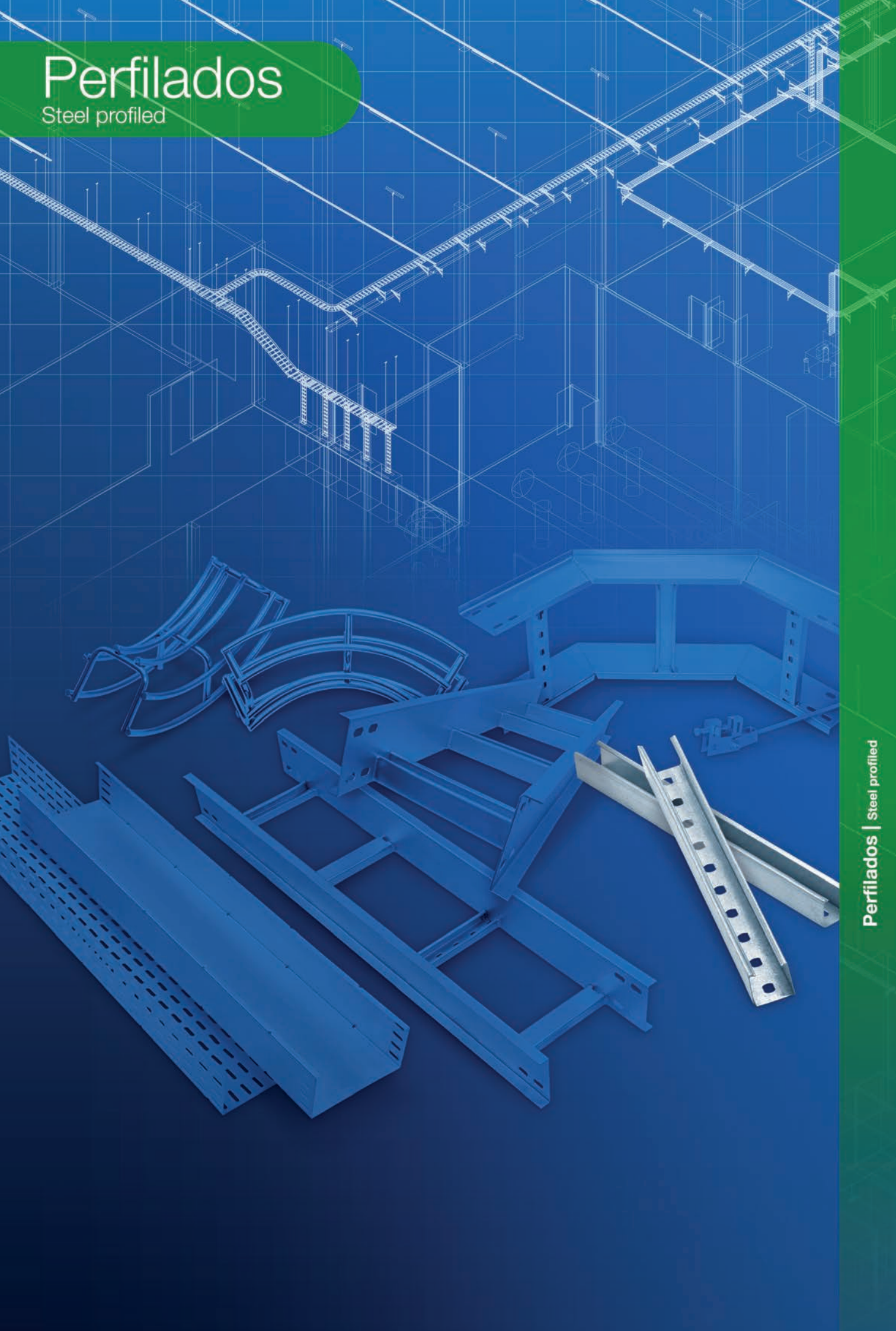

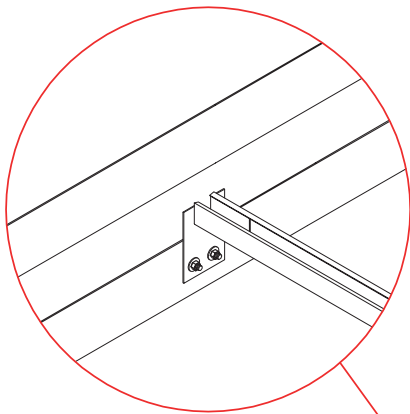

Acoplamento de eletrocalha p/ perfilado 38 x 38 mm DP749.
Cable tray linkage for steel profiles DP 749

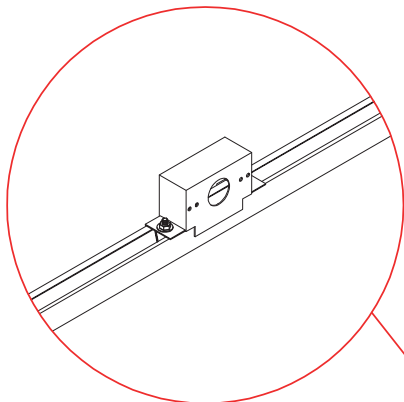

Caixa p/ ligação em perfilado DP 536R
Steel profiled connecting-box DP 536R

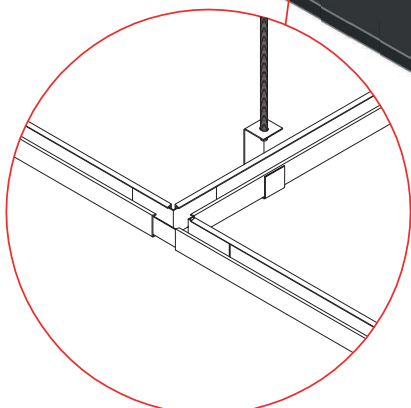
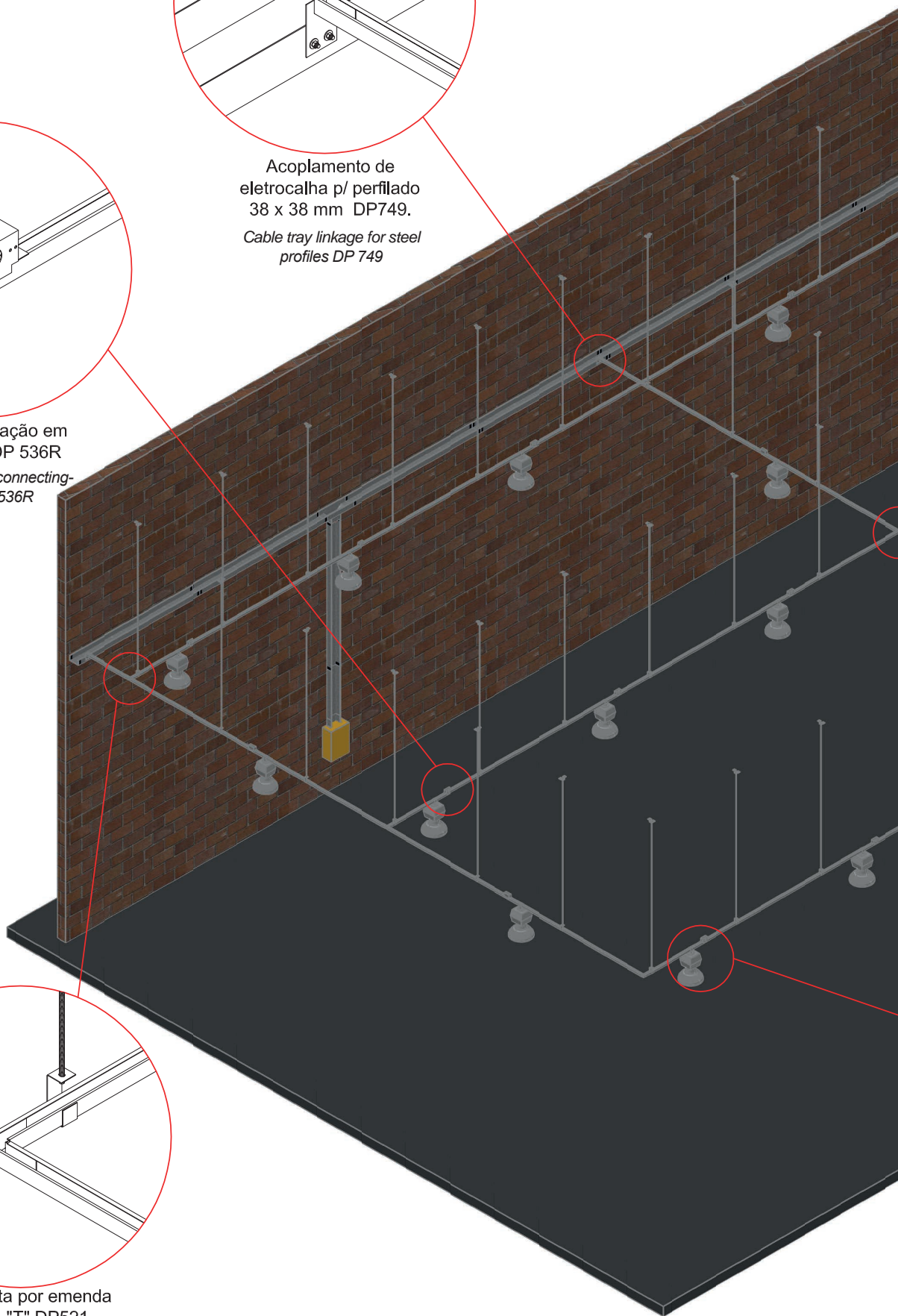

União feita por emenda interna "T" DP521.
Inside joiner "T" as a connection DP 521

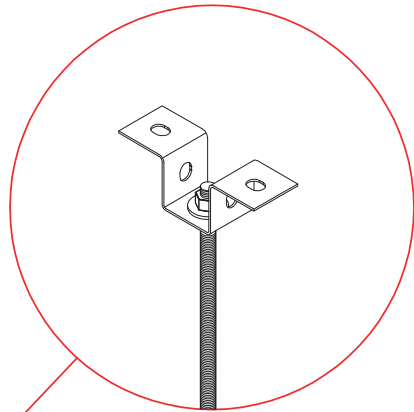
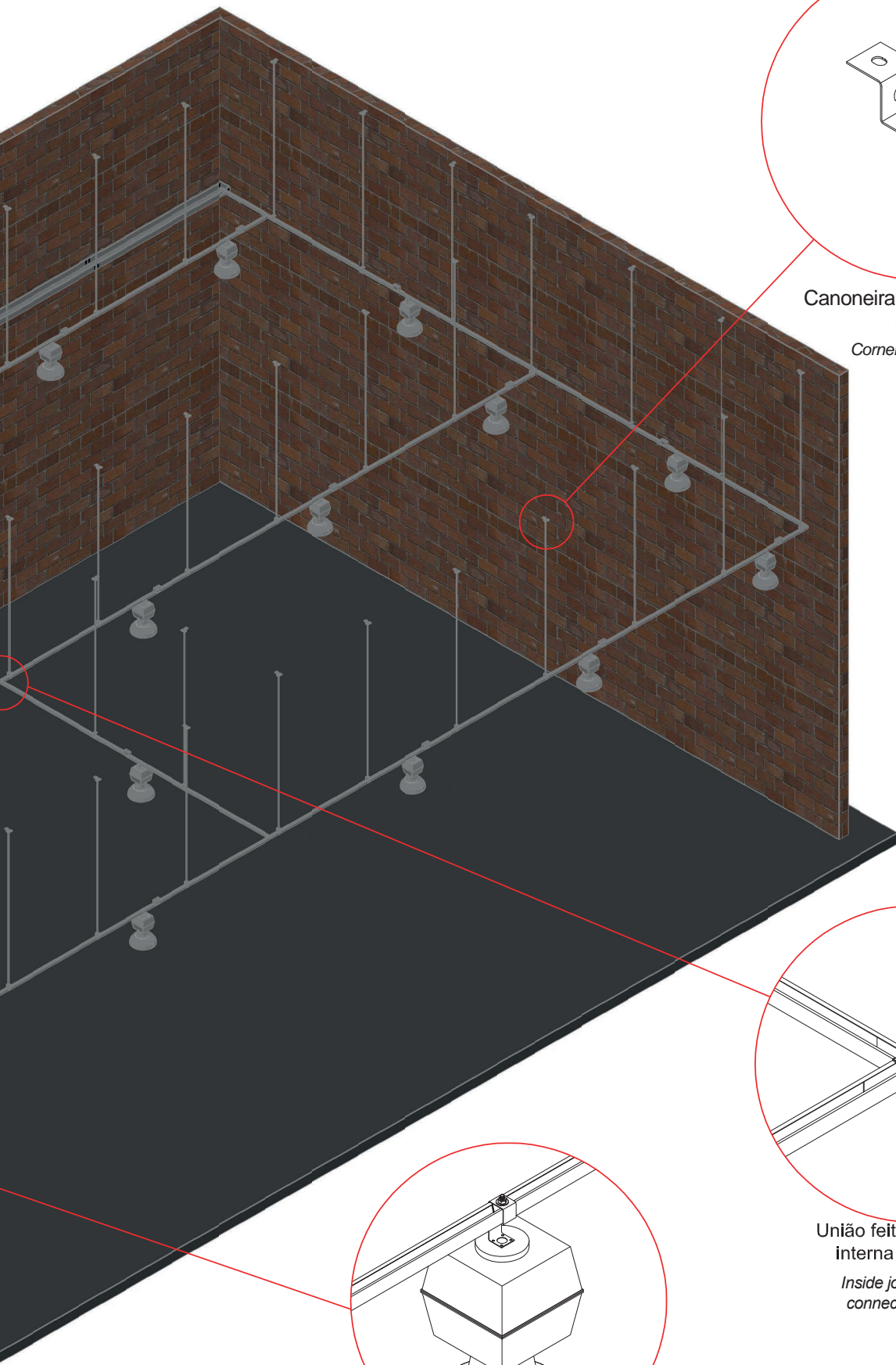

Canoneira "ZZ" p/ vergalhão
DP 584
*Corner "ZZ" for rebar
DP 584*

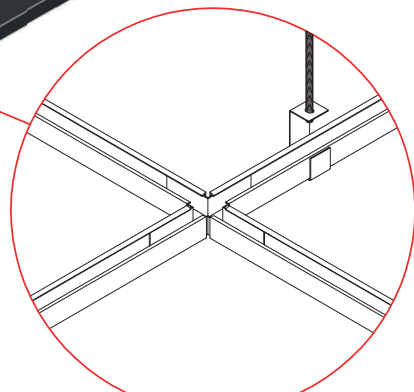

União feita por emenda
interna "X" DP522.
*Inside joiner "X" as a
connection DP 522*

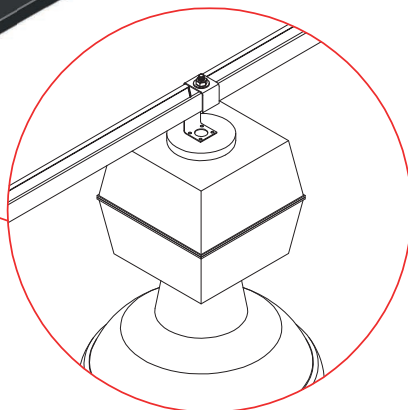

Gancho curto para luminaria
DP 526
*Short clamp for fixture
DP 526*

Como solicitar perfilados

How to specify channels.

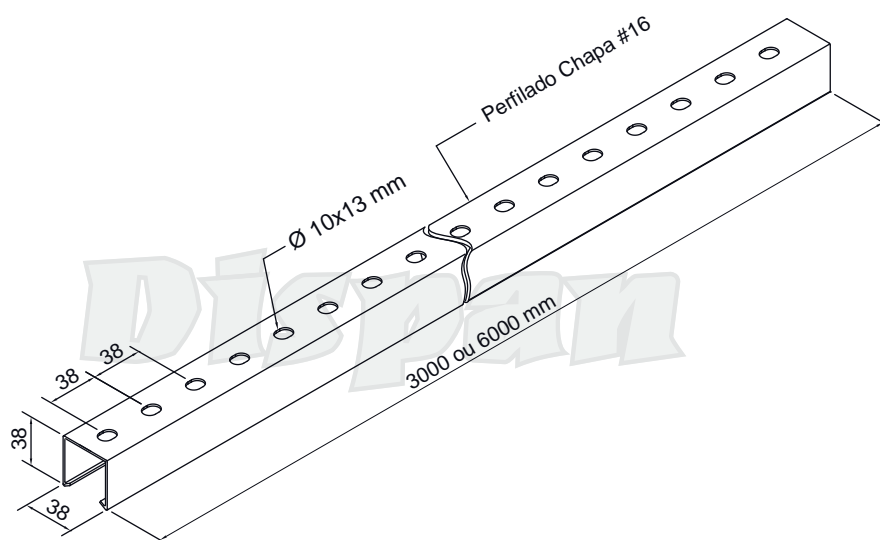

Exemplo
Example

DP502 - AC - GF - 6000 - 16

Referência do catálogo de produtos com características básicas

Product catalog reference with basic features

Matéria-prima de fabricação

Manufacturing raw material

Acabamento
Finish

Comprimento do perfilado

Steel profiled length

Chapas de construção do perfilado

Steel profiled construction's plates

DP 502 • Perfilado perfurado 38 X 38 X 6000 mm
DP 502 • Perforated steel profiled 38 x 38 x 6000 mm

Matéria-prima base
Raw material base

AC - Aço carbono
Carbon Steel

AI - Aço inox
Stainless Steel

AL - Alumínio
Aluminum

Acabamento aplicado na matéria-prima em base de aço carbono

Finish applied to the raw material in carbon steel base

GF - Galvanizado à fogo por imersão
Hot dip galvanized

GE - Galvanizado eletrolítico
Electrolytic galvanized

NT - Natural **PT - Pintado**
Natural Painting

Comprimento:

3000 mm / 6000 mm
Length: 3000 mm / 6000 mm

Espessuras de chapas:
16 - Chapa do perfilado

Plate thickness: 16 - steel profiled plate

Descritivo técnico | Technical description

DP 502 • Perfilado perfurado 38 X 38 X 6000 mm, em aço carbono, galvanizado à fogo, em chapa #16.
DP 502 • Perforated steel profiled 38 x 38 x 6000 mm, carbon steel, hot dip galvanized, plate #16.

Nota

Ocasionalmente podem ocorrer algumas distorções de medidas em nossas peças, por diversos fatores. Por este motivo damos uma tolerância de 5,0 mm entre as medidas mencionadas no catálogo e as peças reais. Os furos oblongos são feitos exatamente para compensação e ajuste de eventuais diferenças.

Note

Occasionally, it may occur some distortion of measures in our pieces, for several reasons. Because of this, we give a toleration of 5.0 mm between the measures mentioned in this catalog and the real pieces. The slotted holes are made just for clearing and settling of any possible differences.

Perfilado perfurado 38x38x6000 mm
with perforations

DP: 502

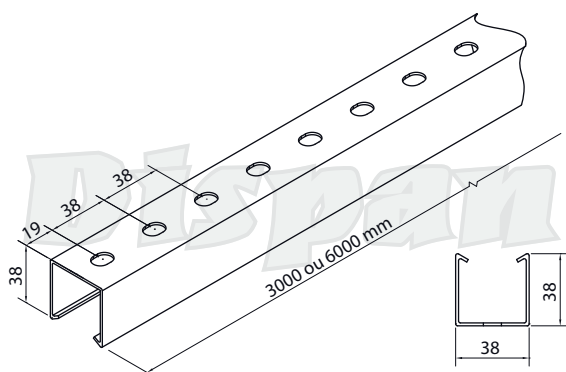

Perfilado c/ 2 furos nas pontas
38x38x6000 mm

with 2 holes at the ends

DP: 503



TABELA DE CARGAS PARA PERFILADOS						
PERFILADO 38x38mm EM AÇO DP - 502 / 503						
CARGA DISTRIBUÍDA UNIFORMEMENTE ENTRE SUPORTES						
		DISTÂNCIA ENTRE SUPORTES				
MEDIDAS mm	CHAPA	01 M	1,5 M	02 M	2,5 M	03 M
38 x 38	20	80	46	40	28	16
38 x 38	18	90	62	55	43	27
38 x 38	16	98	72	64	54	32
38 x 38	14	167	82	75	63	42
38 x 38	12	262	135	80	72	48

Perfilado perfurado 19x38x6000 mm
with perforations

DP: 504

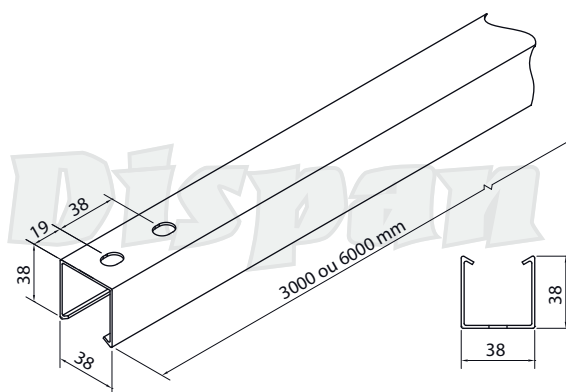
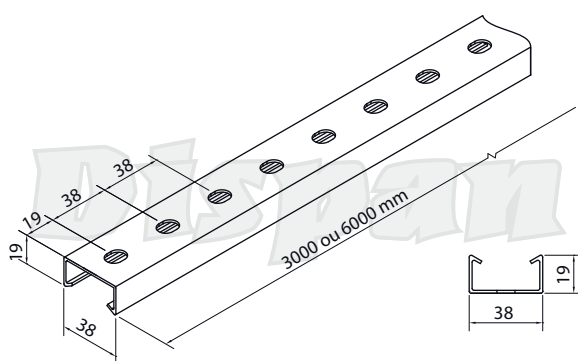

Perfilado liso 19x38x6000 mm
with solid base

DP: 505



TABELA DE CARGAS PARA PERFILADOS						
PERFILADO 38x19mm EM AÇO DP - 504 / 505						
CARGA DISTRIBUÍDA UNIFORMEMENTE ENTRE SUPORTES						
		DISTÂNCIA ENTRE SUPORTES				
MEDIDAS mm	CHAPA	250 mm	500 mm	750 mm	1000 mm	1250 mm
38 x 19	20	132	90	40	28	16
38 x 19	18	180	120	55	43	27
38 x 19	16	240	200	64	54	32
38 x 19	14	275	235	75	63	42
38 x 19	12	320	280	80	72	48

Perfilado liso com 4 furos
38x76x3000 mm

Double, with 4 holes at the ends

DP: 506

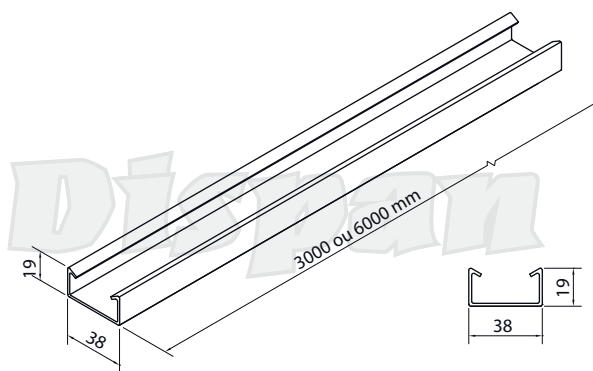
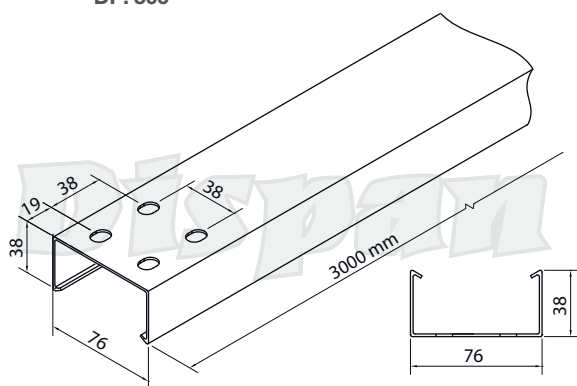

Perfilado perfurado
38x76x3000 mm

Double, with perforations

DP: 507



TABELA DE CARGAS PARA PERFILADOS						
PERFILADO 38x76mm EM AÇO DP - 506 / 507						
CARGA DISTRIBUÍDA UNIFORMEMENTE ENTRE SUPORTES						
		DISTÂNCIA ENTRE SUPORTES				
MEDIDAS mm	CHAPA	01 M	1,5 M	02 M	2,5 M	03 M
38 x 76	20	80	60	40	35	22
38 x 76	18	100	72	50	38	26
38 x 76	16	150	120	100	62	30
38 x 76	14	180	150	120	78	50
38 x 76	12	200	165	145	110	80

Perfilado conjugado 38x76x6000 mm | Welded channel combination

DP: 510

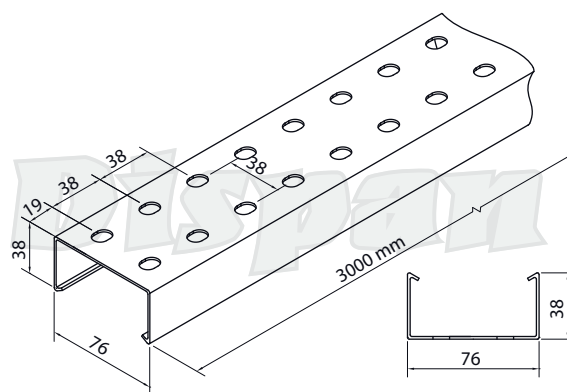

TABELA DE CARGAS PARA PERFILADOS						
PERFILADO CONJUGADO 38x76mm EM AÇO DP - 510						
CARGA DISTRIBUÍDA UNIFORMEMENTE ENTRE SUPORTES						
		DISTÂNCIA ENTRE SUPORTES				
MEDIDAS mm	CHAPA	500 mm	750 mm	1000 mm	1250 mm	1500 mm
38 x 76	18	700	500	400	250	180
38 x 76	16	1000	700	500	350	230
38 x 76	14	1200	900	600	450	310
38 x 76	12	1600	1200	900	600	420

Perfilado conjugado 38x76x6000 mm

Welded channel combination

DP: 508

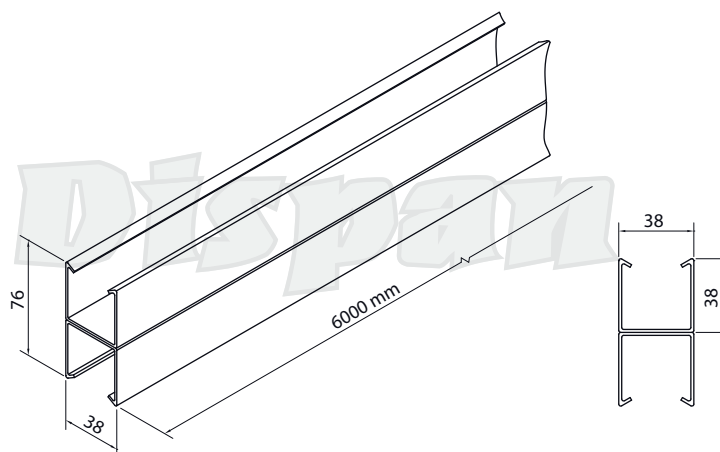
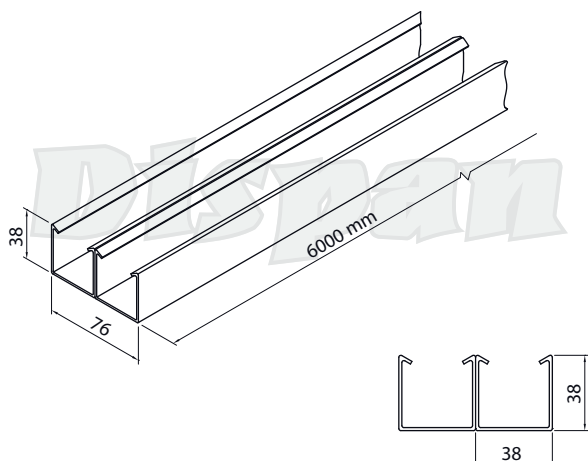

Perfilado conjugado 38x114x6000 mm

Welded channel combination

DP: 509

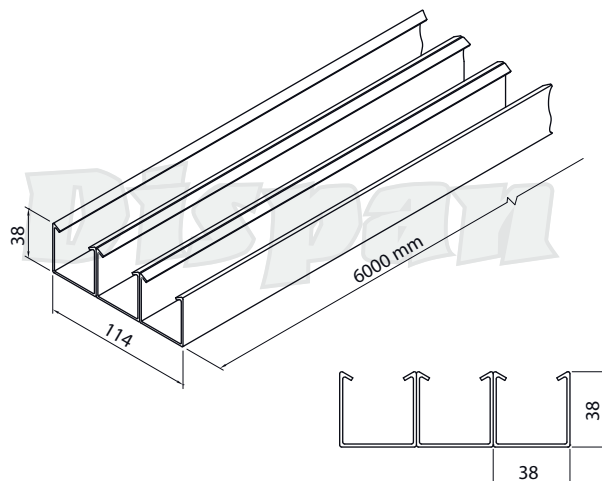

Perfilado conjugado 38x76x6000 mm

Welded channel combination

DP: 510

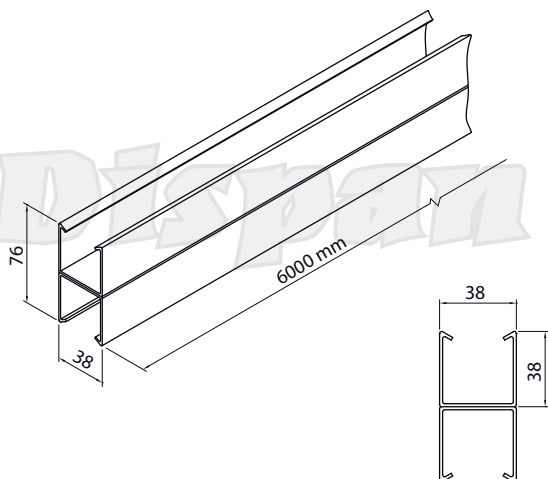

Perfilado conjugado 38x76x6000 mm

Welded channel combination

DP: 511

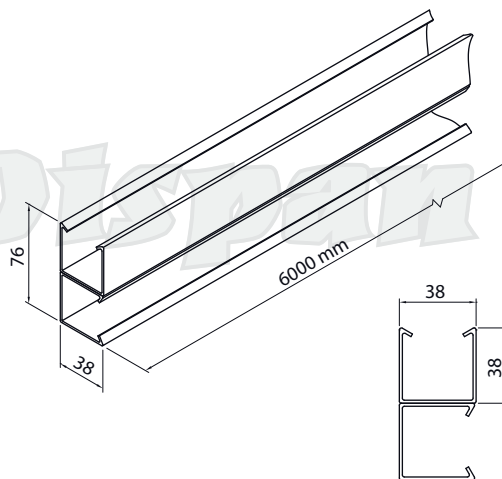

**Tampa de encaixe p/ perfilado
38x3000 mm**

Channel insert cover - 38 mm

DP: 512

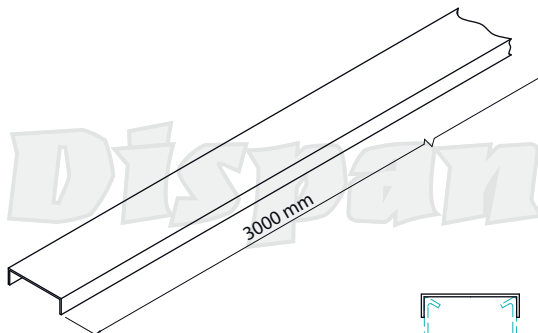

Montagem da tampa
no perfilado.

**Tampa de pressão p/ perfilado
38x3000 mm**

Channel pressure cover 38mm

DP: 513

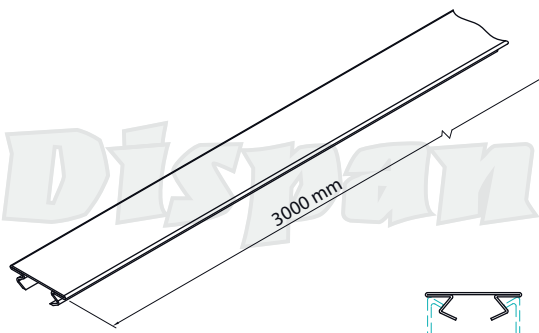

Obs: Somente com
acabamento em PZ

Montagem da tampa
no perfilado.

Tampa de encaixe p/ perfilado duplo
Channel insert cover 76mm

DP: 514

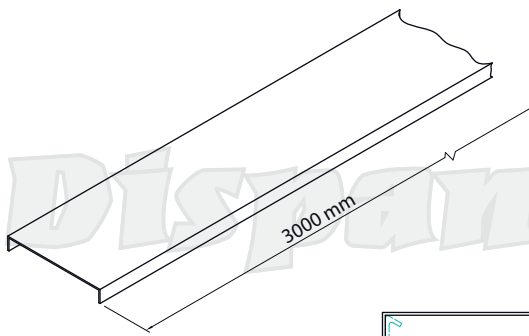

Montagem da tampa no perfilado.

Tampa de pressão p/ perfilado duplo
Channel pressure cover 76mm

DP: 515

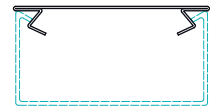
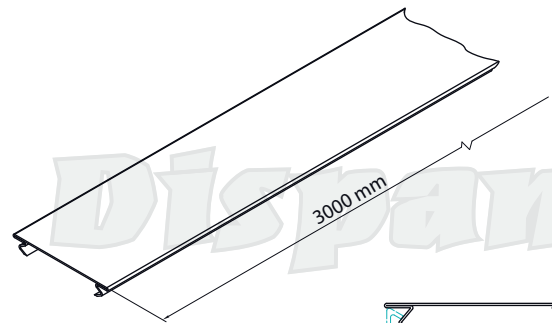

Montagem da tampa no perfilado.

Fita chata perfurada 38x3000 mm
Perforated belt

DP: 516

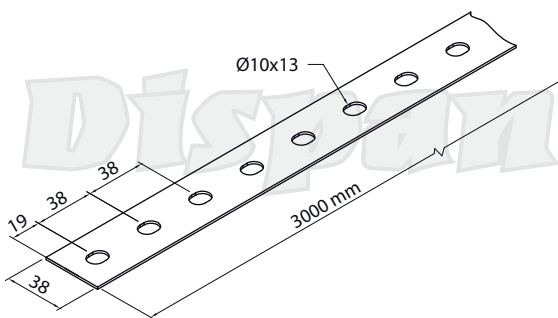

Fabricação nas chapas:
Chapa #16, #14 e #12

Cantoneira "L" 38x38x3000 mm
Perforated angle

DP: 517

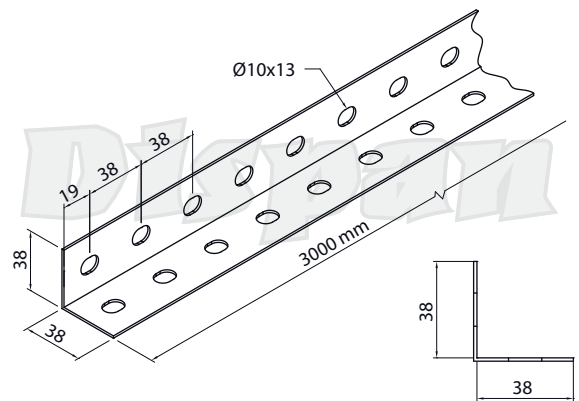

Fabricação nas chapas:
Chapa #16, #14 e #12

Emenda externa "I" | External channel joiner "I"

DP: 518

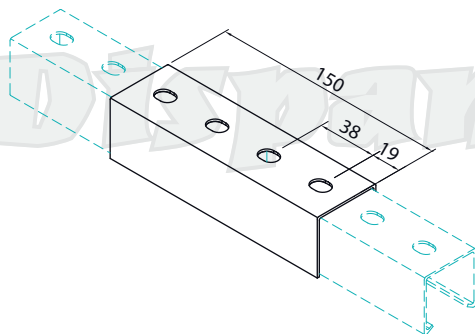

Emenda interna "I" | Internal channel joiner "I"

DP: 519

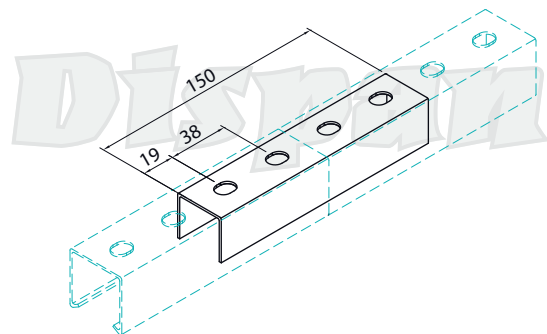

Esquema de montagem emenda interna "I"

Typical applications

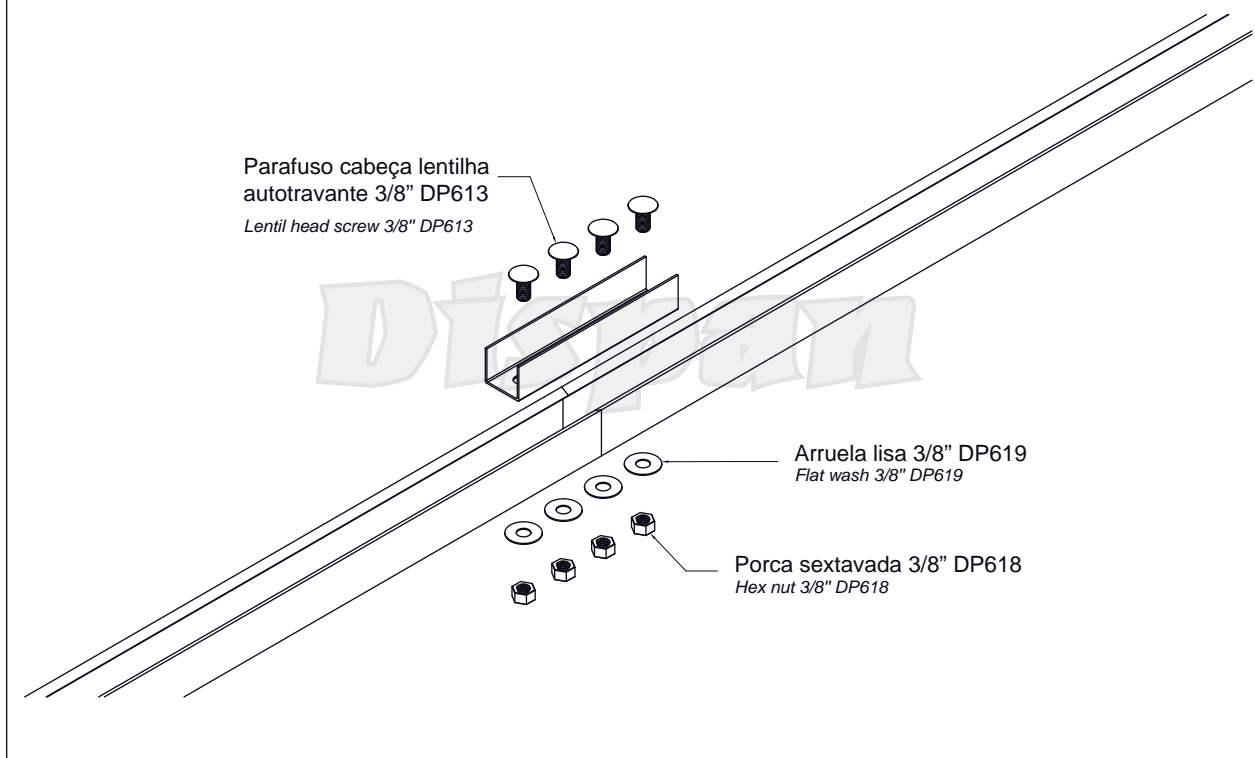

Emenda interna "L"

Internal channel joiner

DP: 520

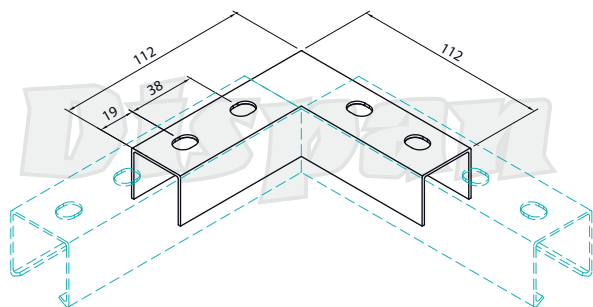

Emenda interna "T"

Internal channel joiner

DP: 521

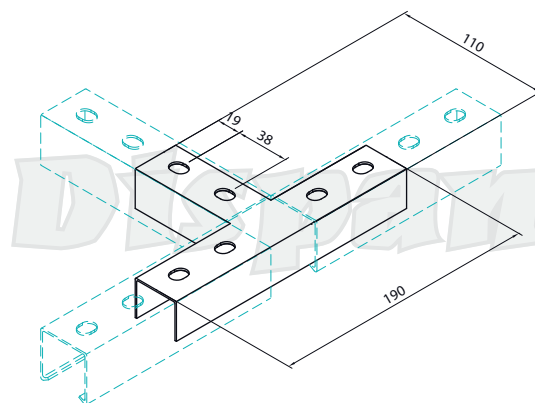

Emenda interna "X"
Internal channel joiner "X"

DP: 522

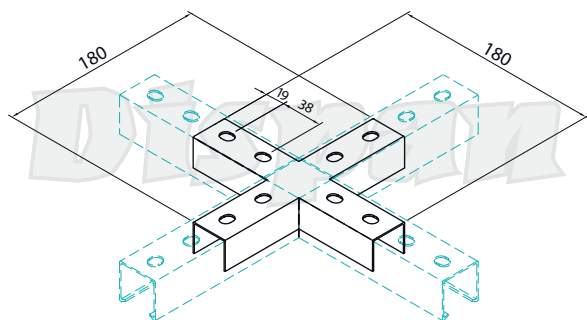

Suspensor p/ cabo 1/8"
Hanger clamp for steel cable

DP: 523

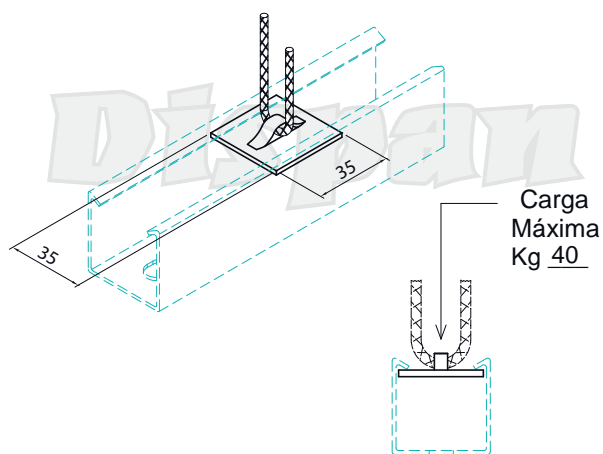

Cantoneira "ZZ" p/ vergalhão
"ZZ" angle conector

DP: 584

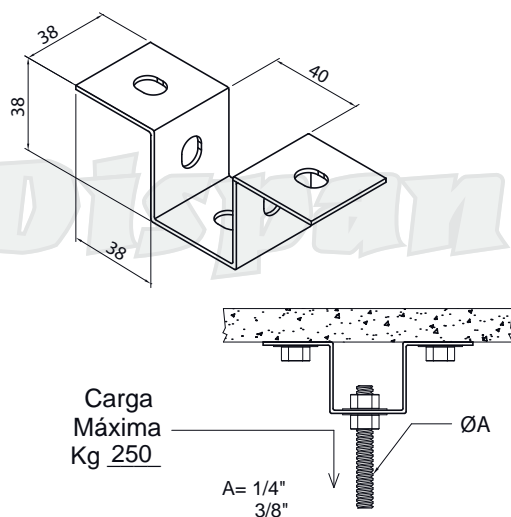

Suporte p/ cabo de aço
Steel cable support

DP: 525

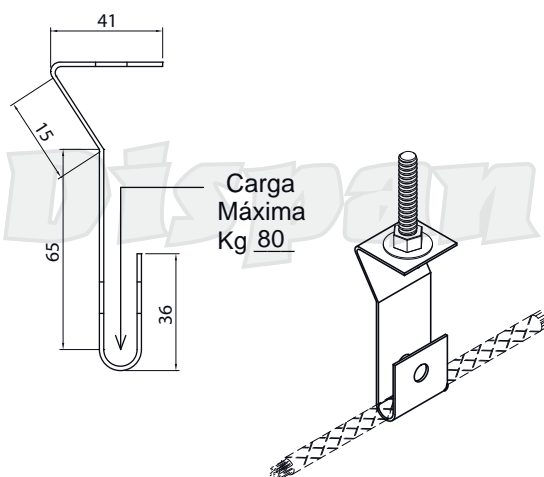

Obs: Ø máx. 3/8".

Gancho curto p/ luminária | Short clamp for fixture

DP: 526

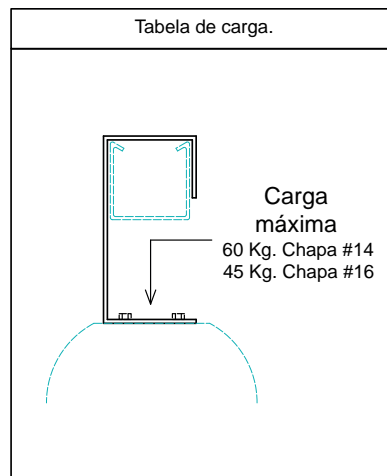
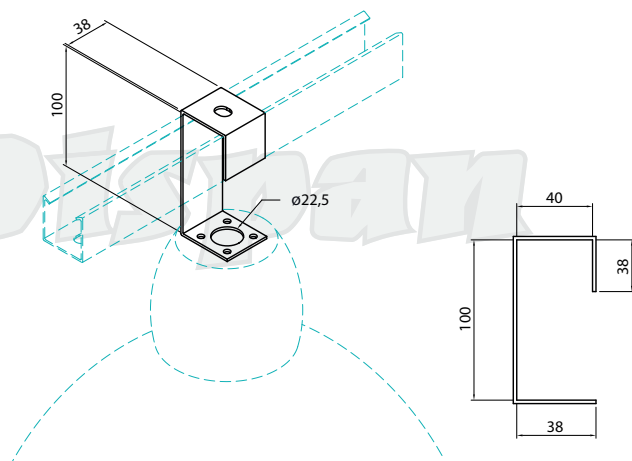

Gancho longo p/ luminária | long clamp for fixture

DP: 527

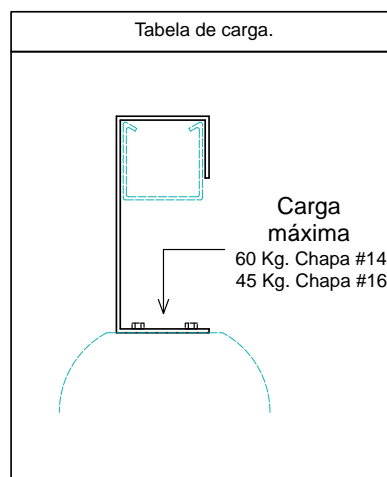
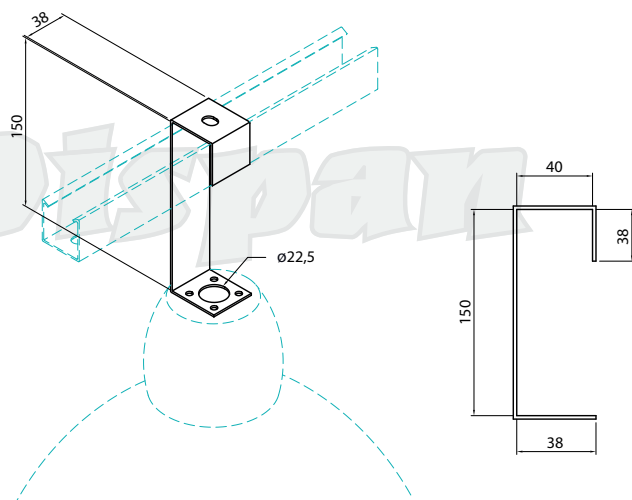

Gancho curto p/ perfilado | Short clamp for channel

DP: 528

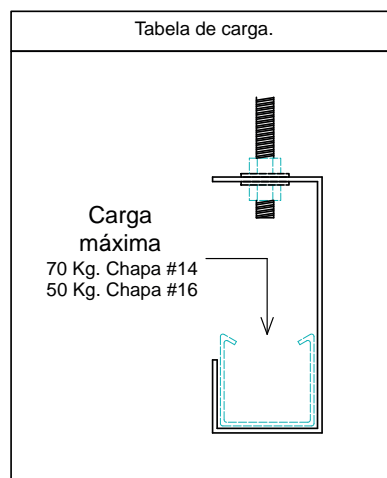
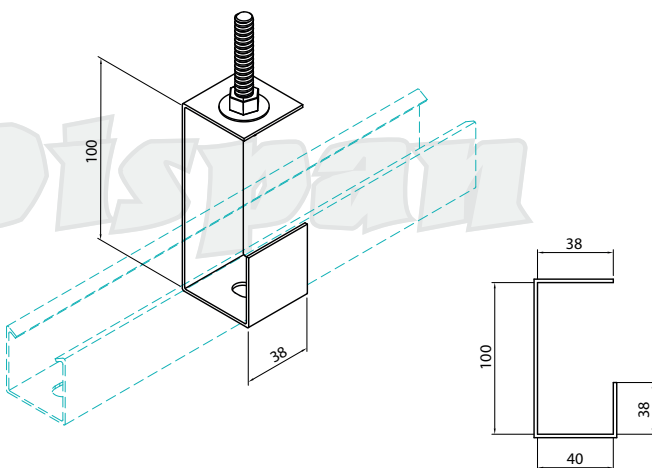

Gancho longo p/ perfilado | long clamp for channel

DP: 529

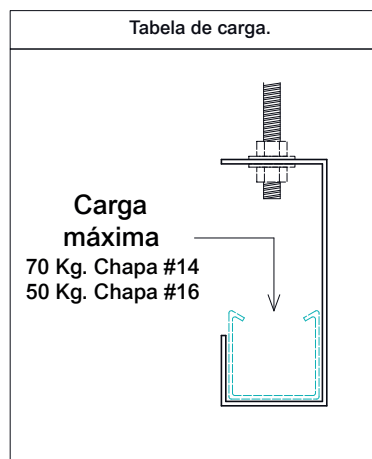
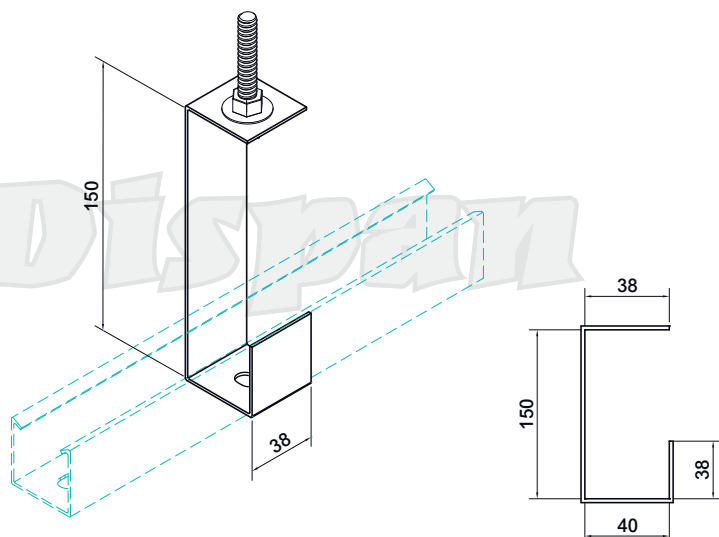

Base p/ ligação em painel

Panel adapter

DP: 530

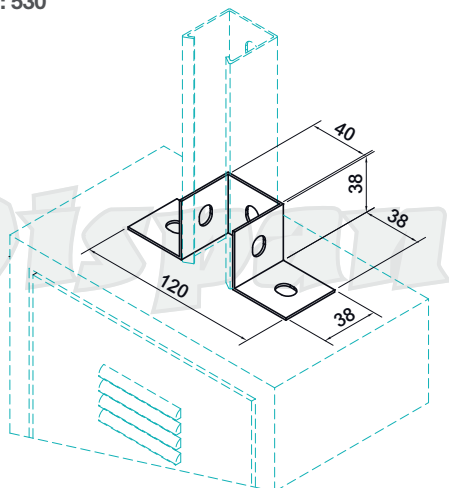

Saída superior p/ eletroduto

Upper outlet for conduit

DP: 531

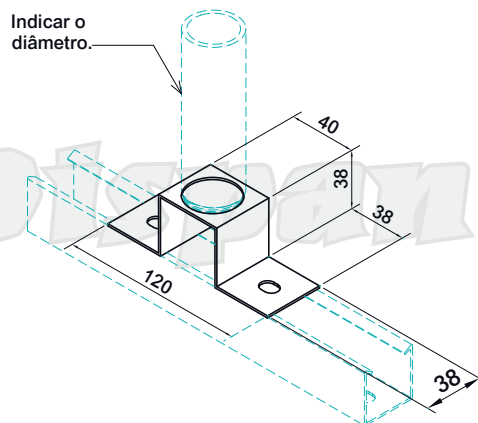

* Disponíveis para os tubos Ø 1/2", 3/4" e 1".

Saída lateral dupla p/ eletroduto

Lateral double outlet for conduit

DP: 532

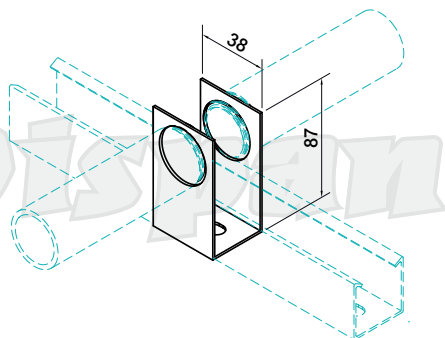

* Disponíveis para os tubos Ø 1/2", 3/4" e 1".

Saída simples p/ eletroduto

Lateral outlet for conduit

DP: 533

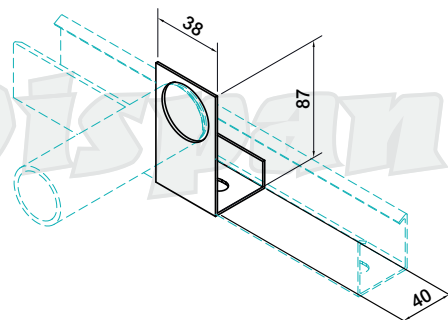

* Disponíveis para os tubos Ø 1/2", 3/4" e 1".

Saída final p/ eletroduto
End outlet conduit

DP: 534

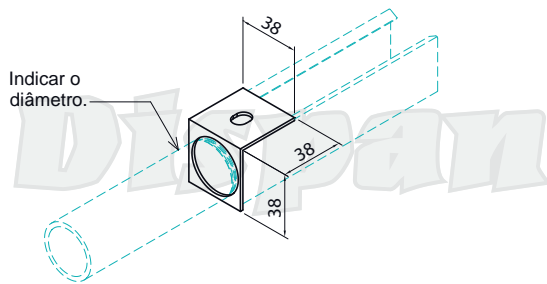

* Disponíveis para os tubos Ø 1/2", 3/4" e 1".

Arruela adaptadora
Saddle type washer

DP: 535

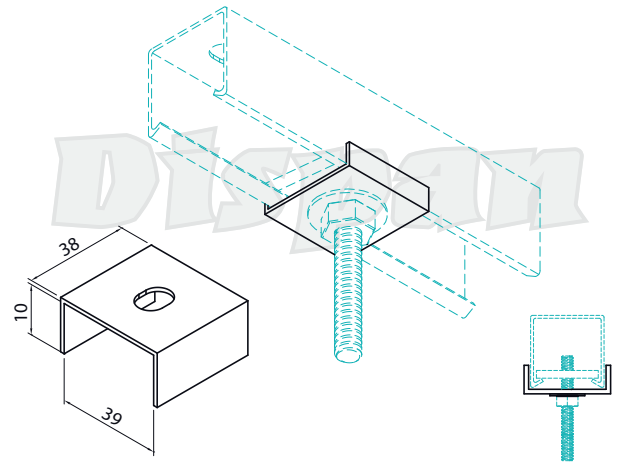

Caixa p/ tomada em perfilado
Channel box for electric outlets

DP: 536

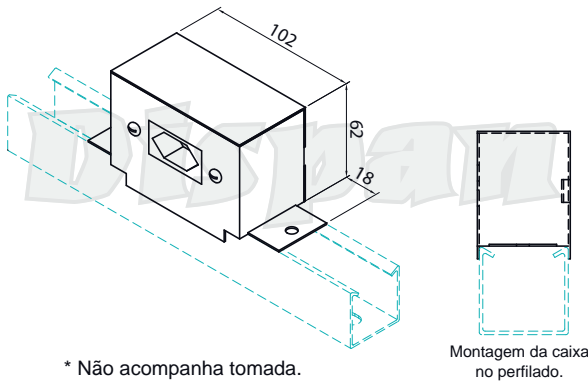

* Não acompanha tomada.

Caixa p/ tomada em perfilado
Channel box for electric outlets

DP: 536R

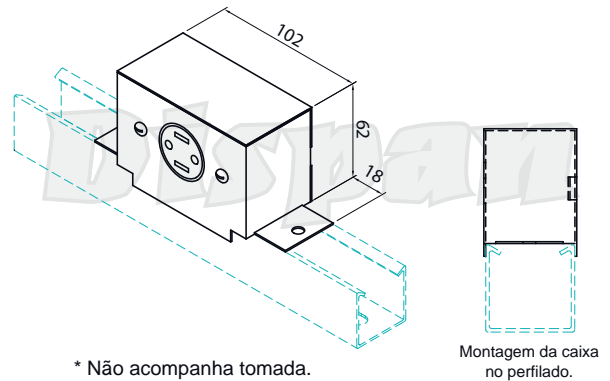

* Não acompanha tomada.

Caixa de ligação p/ perfilado
Channel box

DP: 537

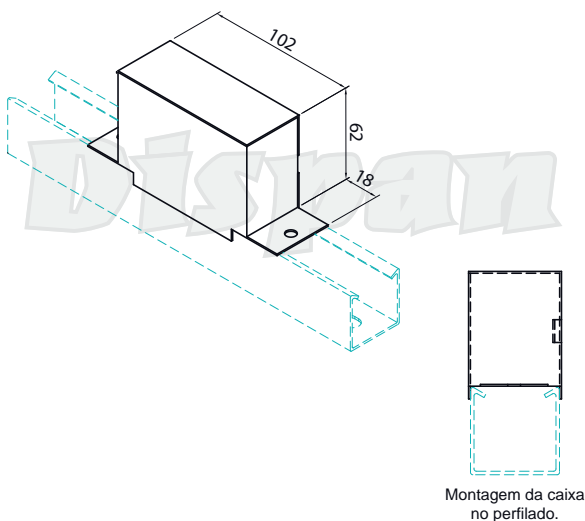

Montagem DP 536 / DP 537
Mounting

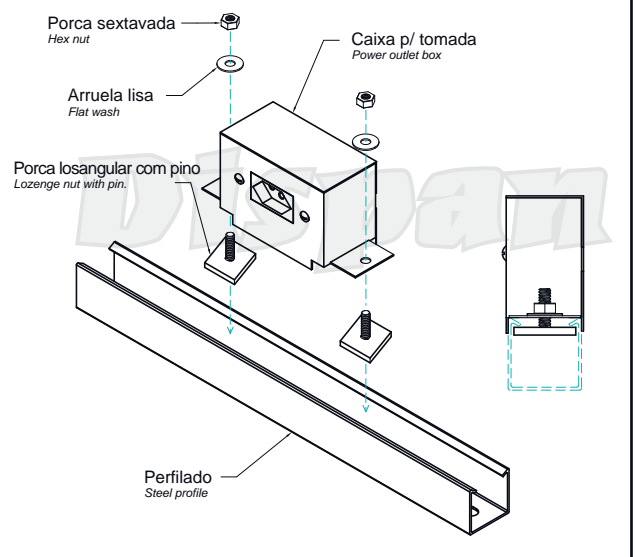

Grampo "C" | Beam clamp "C"

DP: 538

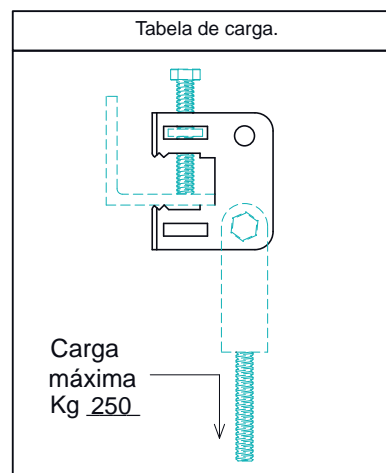
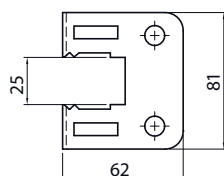
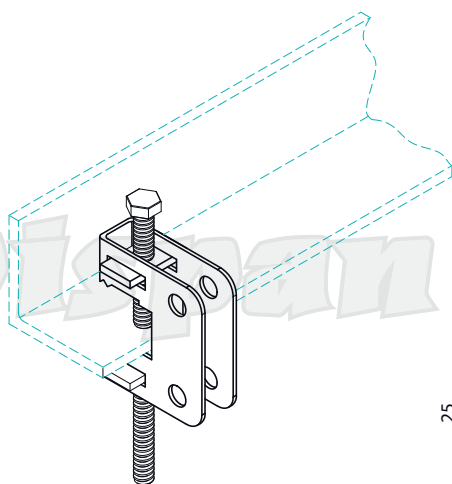

Presilha p/ grampo "C"

DP: 539

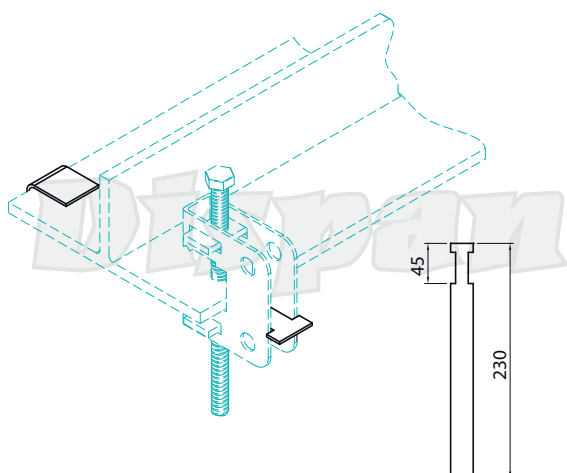

Balancim p/ grampo "C"

Swing connector for beam clamp

DP: 540

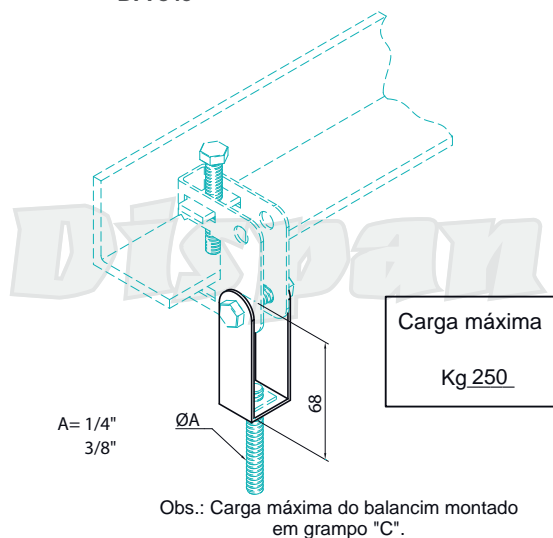

Cabo de aço diâmetro 1/8"

DP: 541

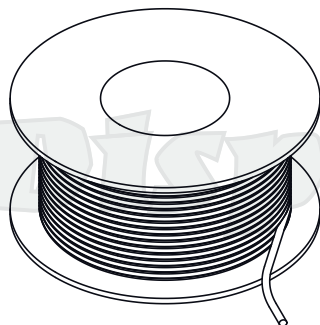

* Disponíveis nas bitolas de 1/8" e 3/16".

Base interna c/ 1 furo

Internal base 1 - hole

DP: 542

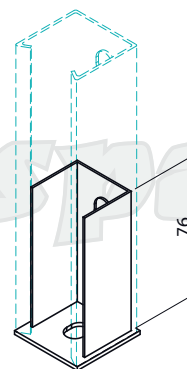

Base interna c/ 4 furos

Internal base 4 - holes

DP: 543

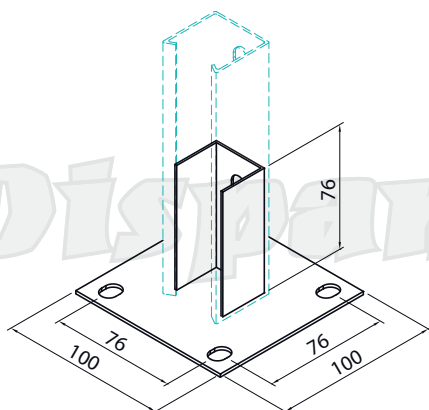

Base externa c/ 4 furos

External base 4 - holes

DP: 544

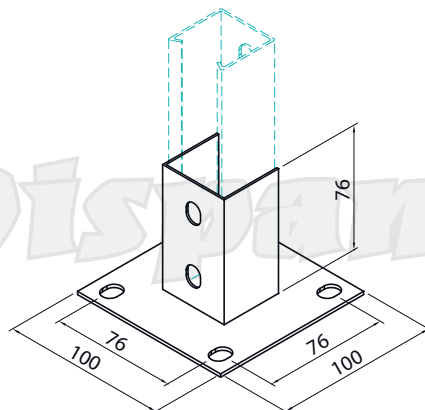

Caixa de derivação com tampa

Caixa de derivação "L" p/ perfilado 38x76 mm com saída p/ perfilado 38x38 mm à direita
"L" right junction box 76X38 mm

DP: 546D

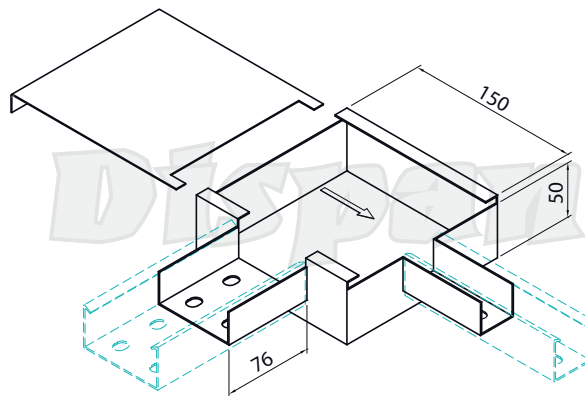
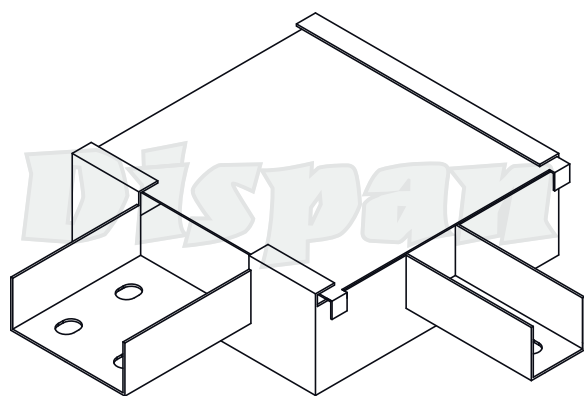

Caixa de derivação "L" p/ perfilado 38x76 mm com saída p/ perfilado 38x38 mm à esquerda
"L" left junction box 76X38 mm

DP: 546E

Caixa de derivação "T" p/ perfilado 76x38 mm com saída p/ perfilado 38x38 mm
"T" junction box 76X38 mm

DP: 547

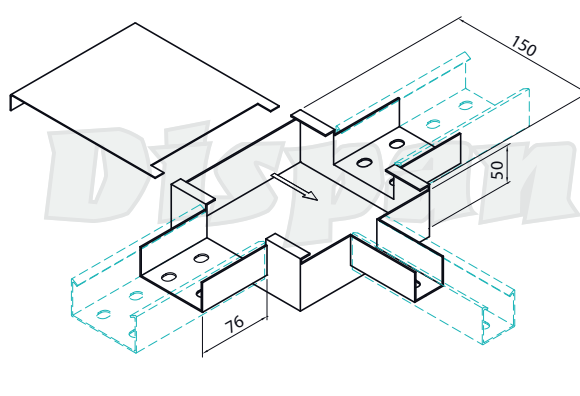
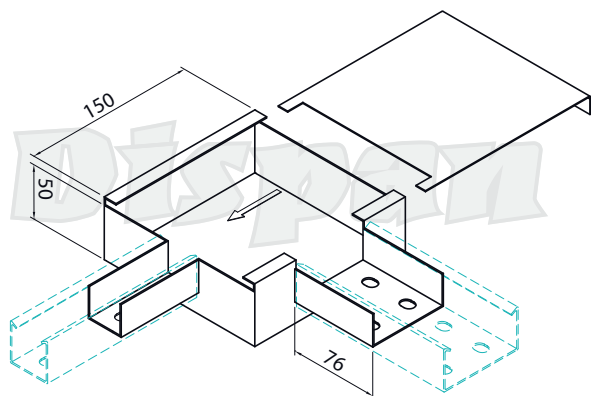

Caixa de derivação "I" p/ perfilado
38X38 mm | "I" junction box

DP: 548

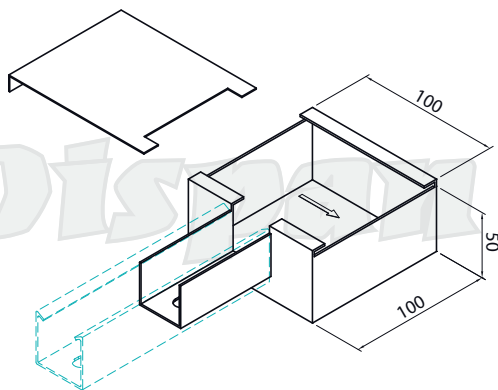

Caixa de derivação "C" p/ perfilado
38X38 mm | "C" junction box

DP: 549

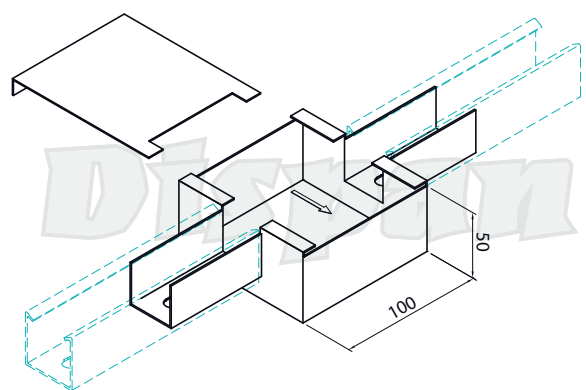

Caixa de derivação "L" p/ perfilado
38X38 mm | "L" junction box

DP: 550

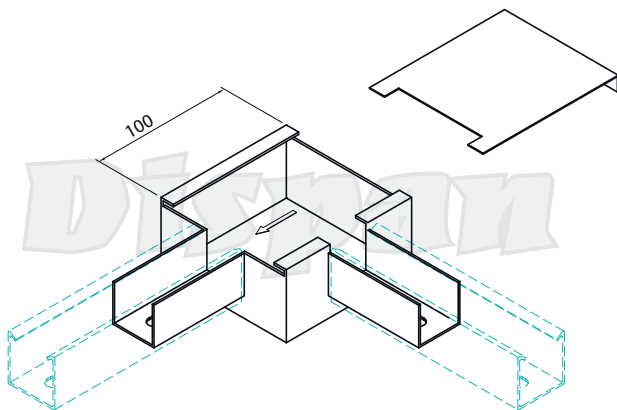

Caixa de derivação "T" p/ perfilado
38X38 mm | "T" junction box

DP: 551

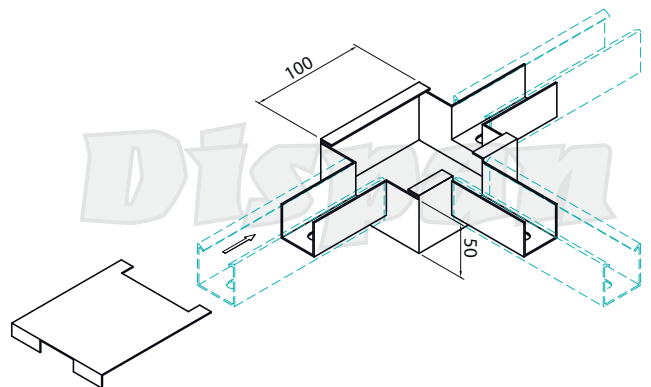

Caixa de derivação "X" p/ perfilado
38X38 mm | "L" junction box

DP: 552

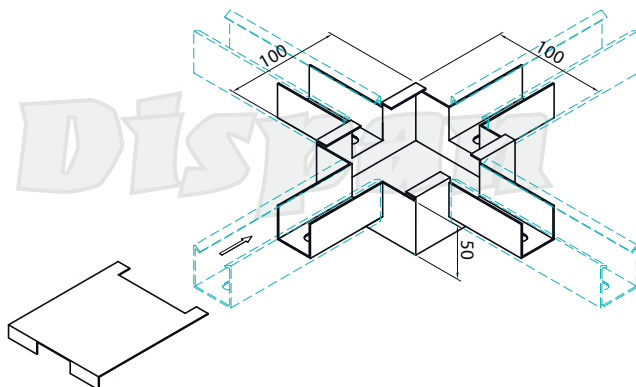

Caixa de derivação "I" c/ saída inferior p/ perfilado 38X38 mm
"I" junction box with bottom outlet

DP: 553

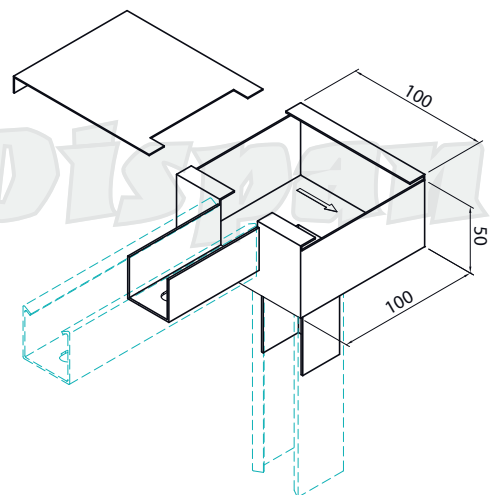

Base externa dupla c/ 4 furos

Double lower base 4 - holes

DP: 554

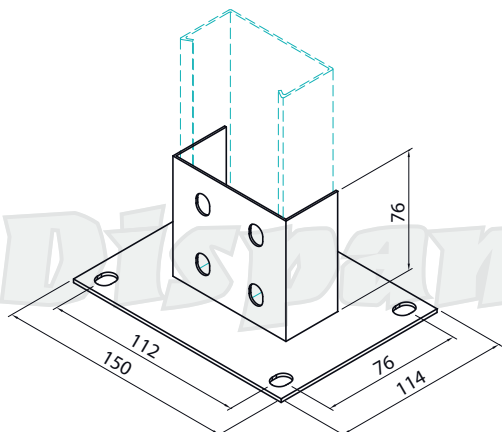

Base dupla p/ ligação em painel

Double panel adapter

DP: 555

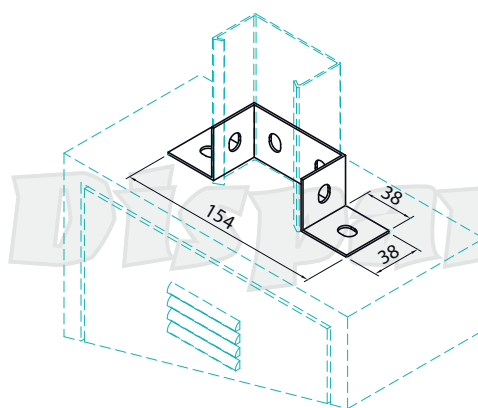

Emenda externa "I" 38x76 mm

"I" external junction

DP: 556

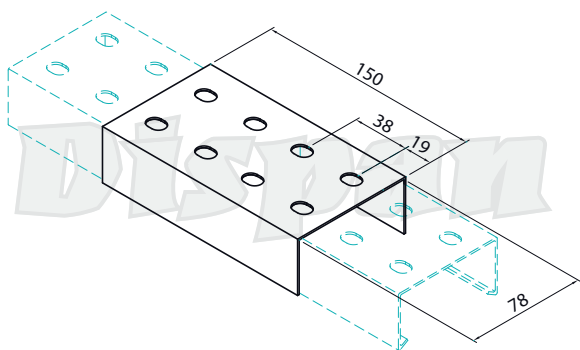

Emenda interna "I" 38x76 mm

"I" internal junction

DP: 557

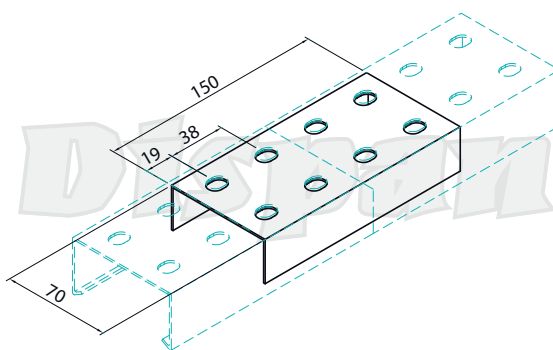

Emenda interna "L" 38x76 mm

"L" internal junction

DP: 558

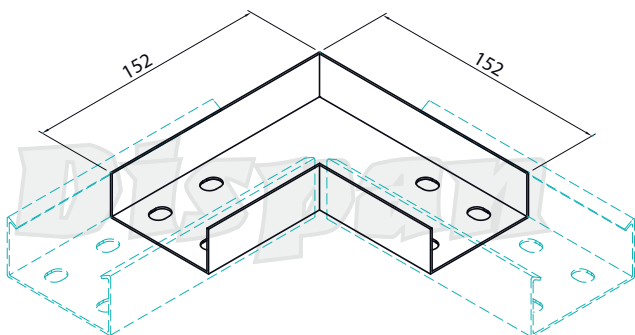

Emenda interna "T" 38x76 mm

"T" internal junction

DP: 559

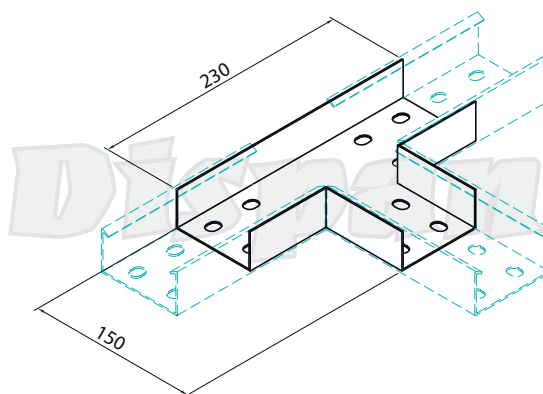

Emenda interna "X" 38x76 mm | "X" internal junction

DP: 560

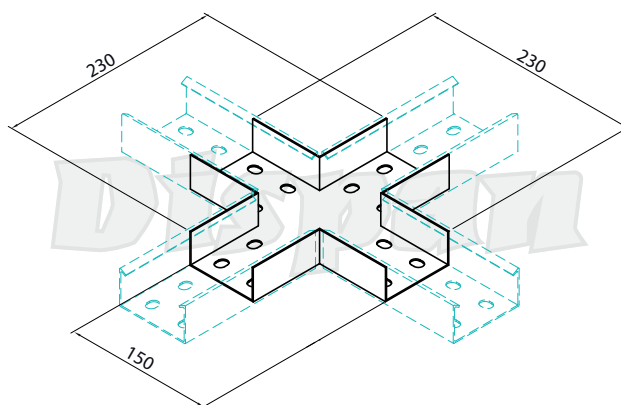

Gancho curto p/ perfilado 38x76 mm | Hanger for double channel

DP: 561

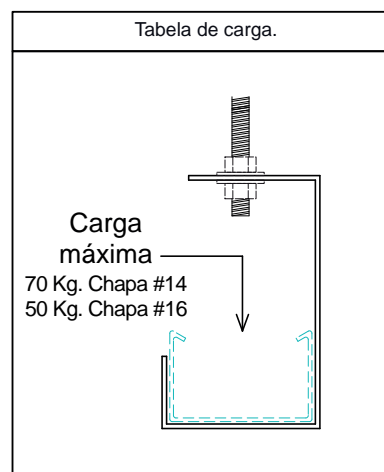
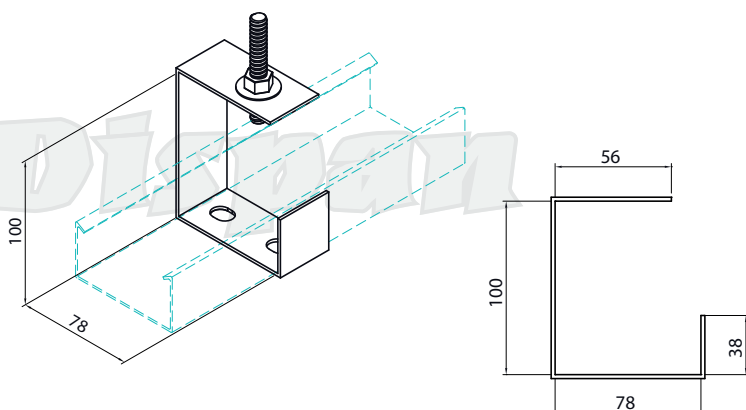

Gancho longo p/ perfilado 38x76 mm | Long hanger for double channel

DP: 562

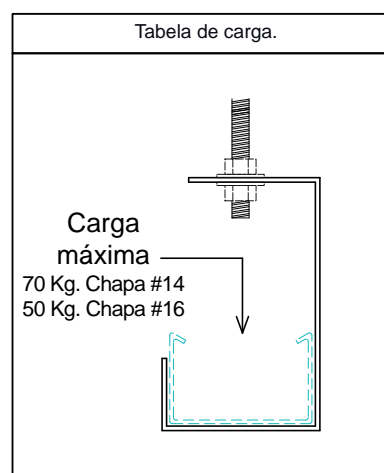
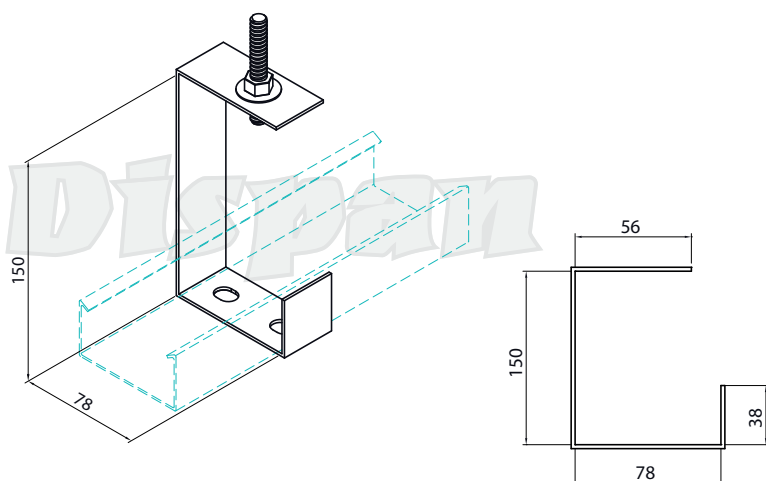

Redução concêntrica 76x38 mm

76x38 mm box channel reducer

DP: 563

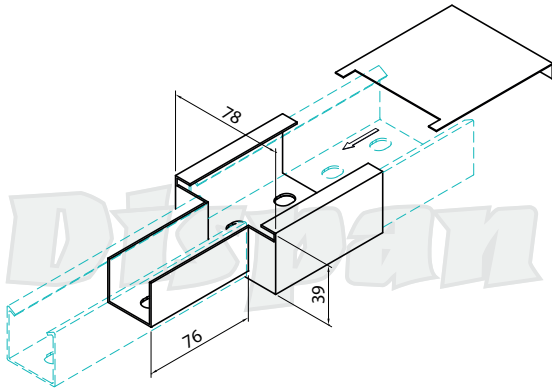

Caixa de derivação "I"

p/ perfilado 38x76 mm

"I" junction box for double channels

DP: 564

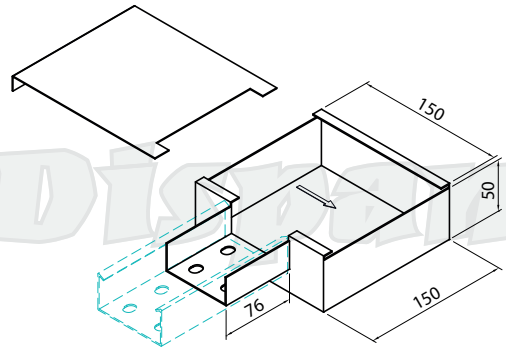

Caixa de derivação "C"

p/ perfilado 38x76 mm

"C" junction box for double channels

DP: 565

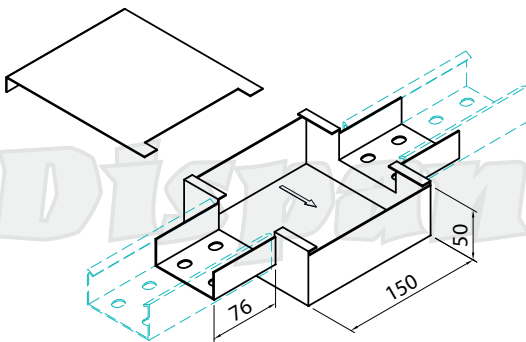

Caixa de derivação "L"

p/ perfilado 38x76 mm

"L" junction box for double channels

DP: 566

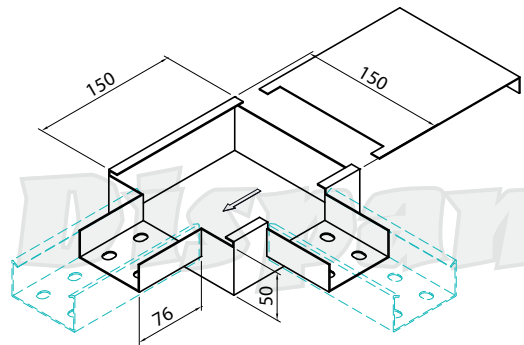

Caixa de derivação "T"

p/ perfilado 38x76 mm

"T" junction box for double channels

DP: 567

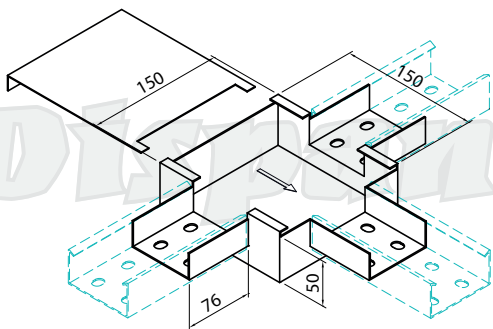

Caixa de derivação "X"

p/ perfilado 38x76 mm

"X" junction box for double channels

DP: 568

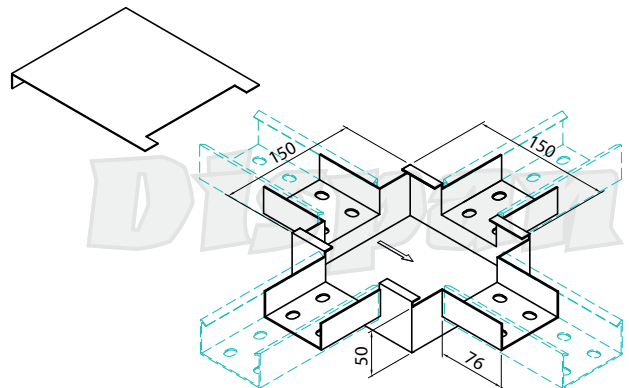

Caixa de derivação "C" c/ saída inferior p/ perfilado 38x76 mm

"C" junction box for double channel with one bottom outlet

DP: 569

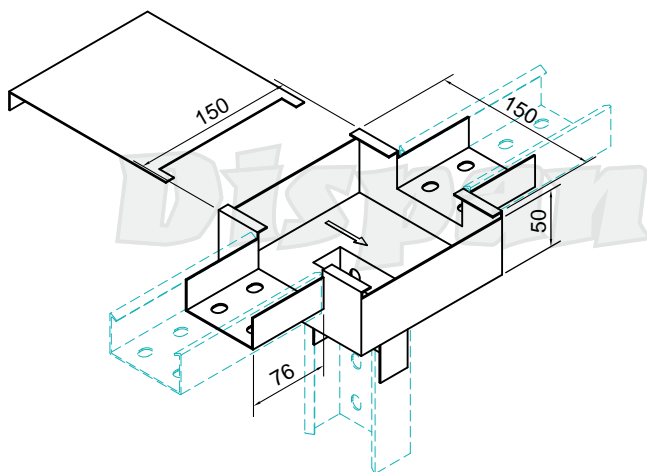

Caixa de derivação "I" c/ saída inferior p/ perfilado 38x76 mm

"I" junction box for double channel with one bottom outlet

DP: 570

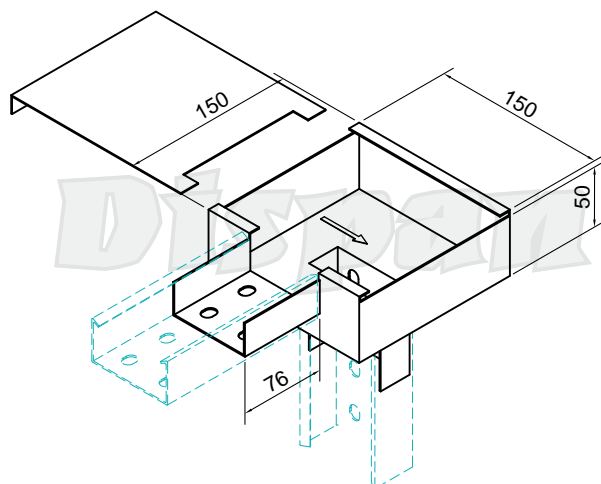

Caixa de derivação "C" c/ saída inferior 38x38 mm

"C" junction box for 76 mm and bottom outlet for 38 channel

DP: 571

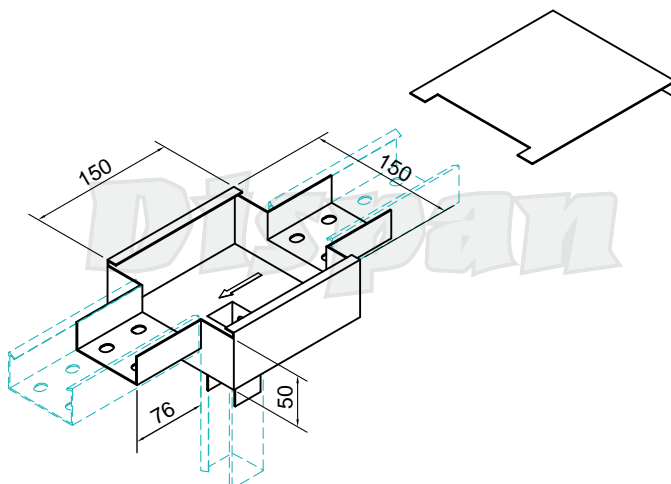

Cantoneira c/ 2 furos simples

Two hole angle connector

DP: 572

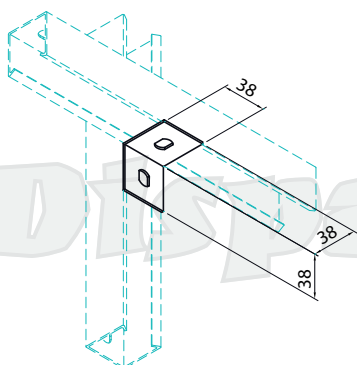

Cantoneira c/ 3 furos simples

Three hole angle connector

DP: 573

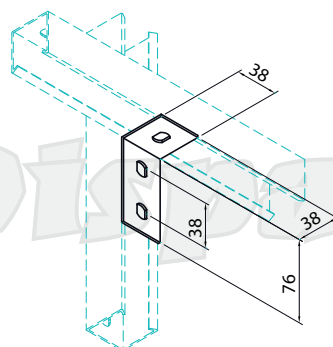

Cantoneira c/ 4 furos simples

Four hole angle connector

DP: 574

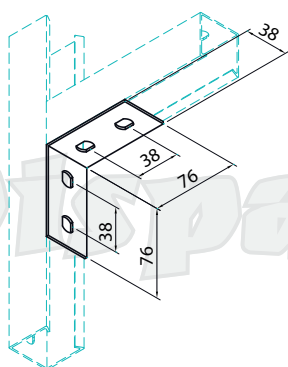

Cantoneira c/ 5 furos simples

Five hole angle connector

DP: 575

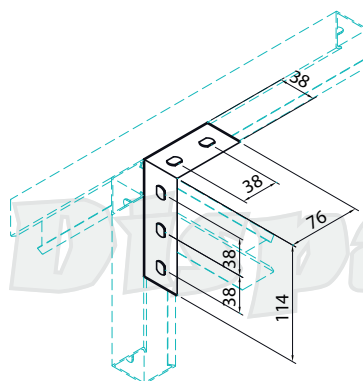

Cantoneira c/ 6 furos simples

Six hole angle connector

DP: 576

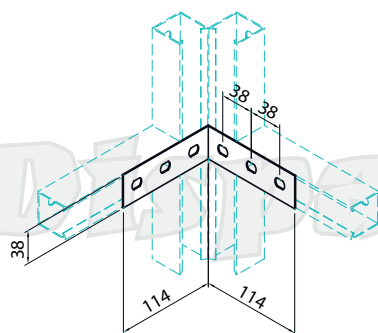

Cantoneira c/ 1 furo e 1 rasgo

One hole - one slot angle connector

DP: 577

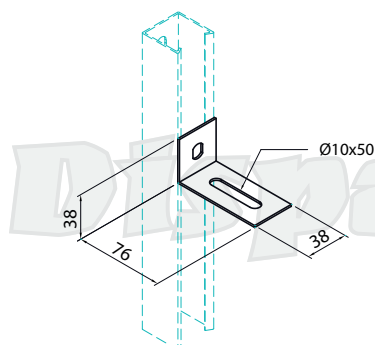

Cantoneira c/ 2 furos e 1 rasgo

Two hole - one slot angle connector

DP: 578

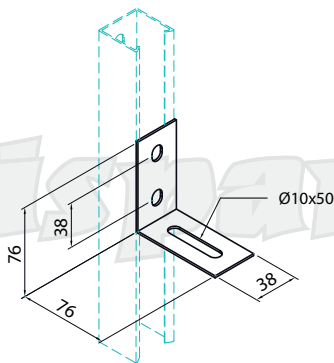

Cantoneira c/ 2 furos reforçada

Reinforced two hole angle connector

DP: 579

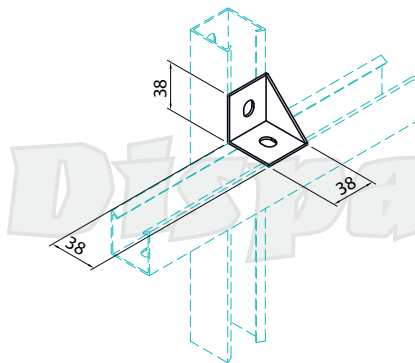

Cantoneira c/ 4 furos reforçada

Reinforced four hole angle connector

DP: 580

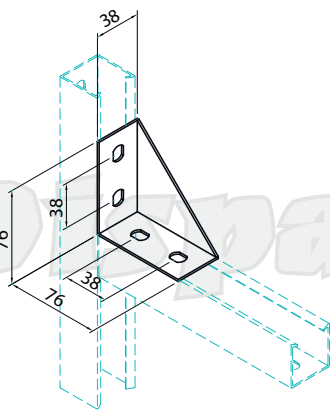

Cantoneira "Z" meia

Z - support for 19 deep channel

DP: 581

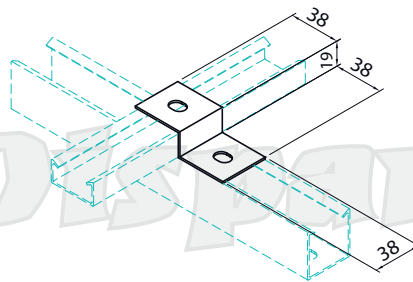

Cantoneira "Z"

Z - support for 38 deep channel

DP: 582

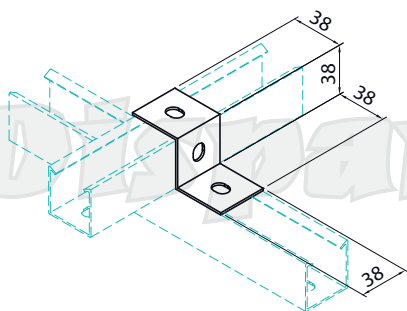

Cantoneira "ZZ" meia

ZZ - support for 19 deep channel

DP: 583

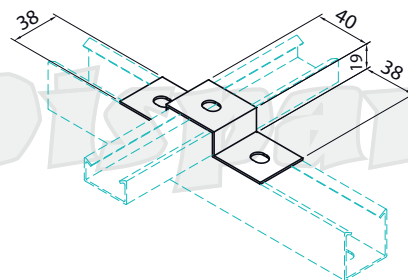

Cantoneira "ZZ"

ZZ - support for 38 deep channel

DP: 584

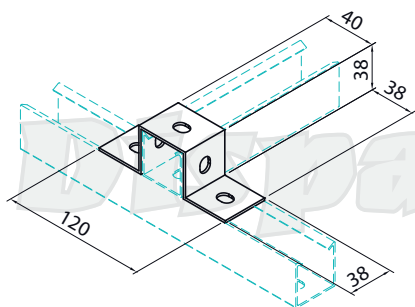

Cantoneira "ZZ" dupla vertical

ZZ - support for two vertical 38 deep channel

DP: 585

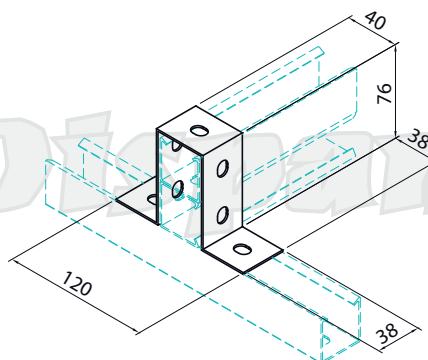

Cantoneira "ZZ" dupla horizontal

ZZ - support for two horizontal 38 deep channel

DP: 586

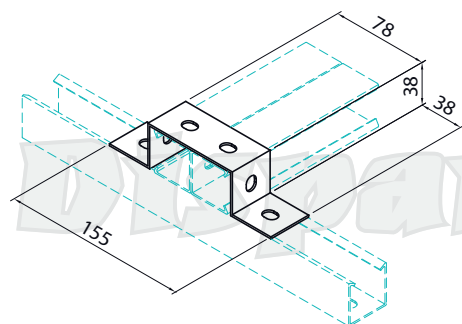

Distanciador c/ 1 furo

Separator 1 hole

DP: 587

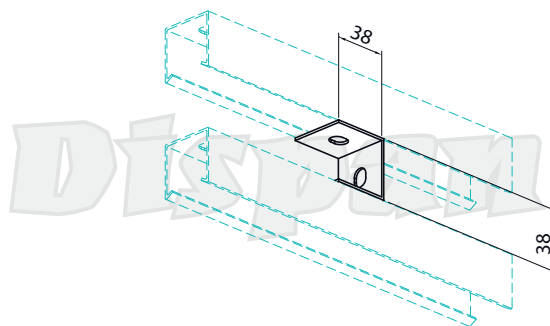

Distanciador c/ 2 furos

Separator 2 hole

DP: 588

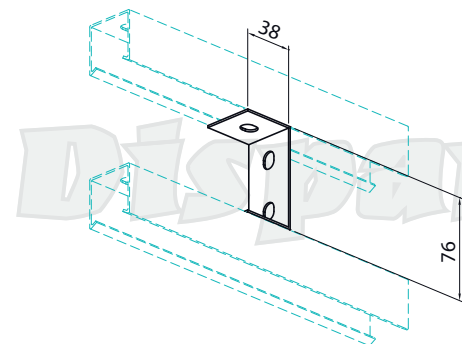

Distanciador c/ 3 furos

Separator 3 hole

DP: 589

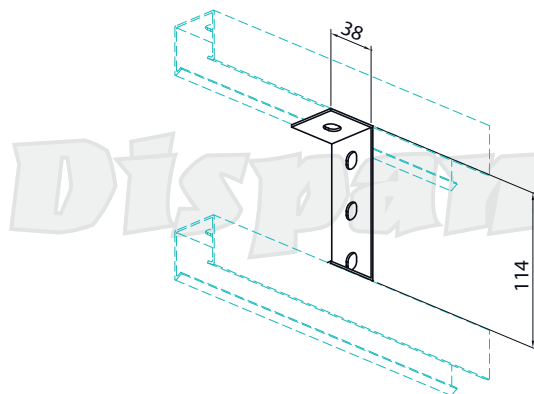

Distanciador c/ 4 furos

Separator 4 hole

DP: 590

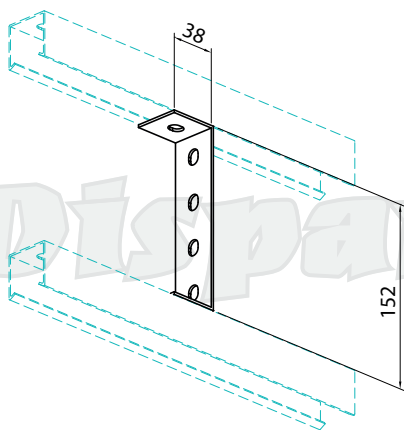

Junção plana "L"

"L" plate connector

DP: 591

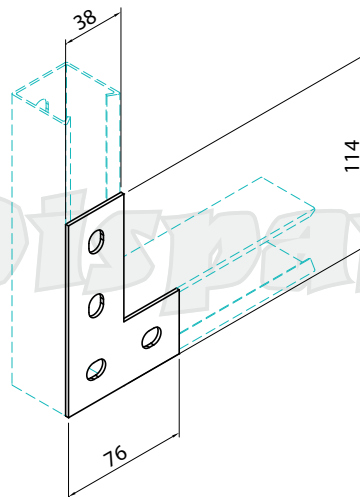

Junção plana "T"

"T" plate connector

DP: 592

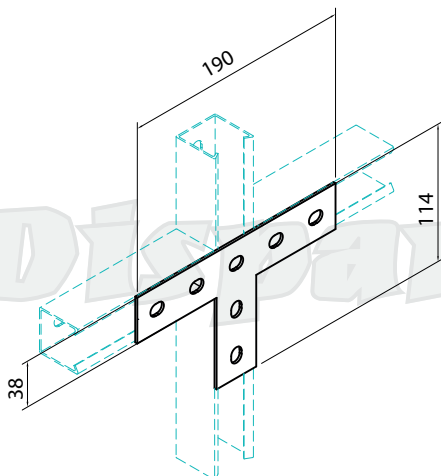

Junção plana "L" reforçada

Four hole "L" - plate connector

DP: 593

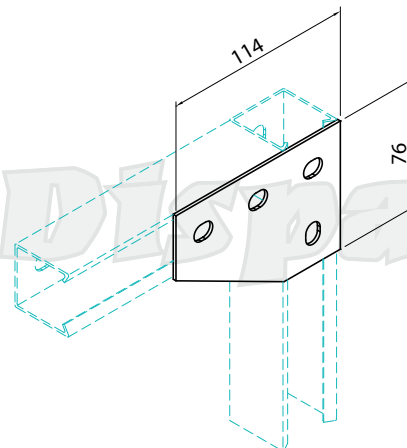

Junção plana "T" reforçada

Five hole "T" - plate connector

DP: 594

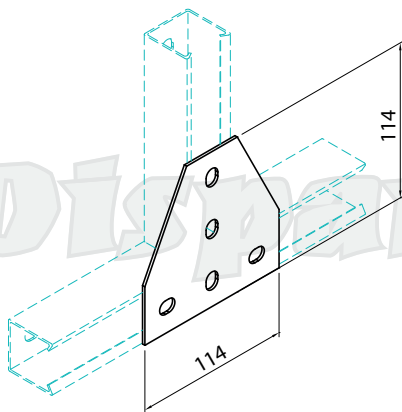

Junção plana "X" reforçada

Seven hole "X" - plate connector

DP: 595

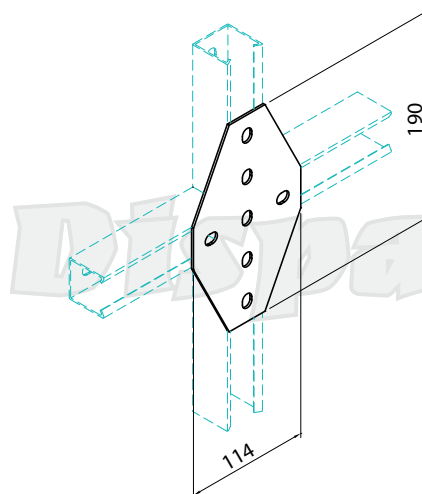

Tala simples c/ 1 furo

One hole plate connector

DP: 596

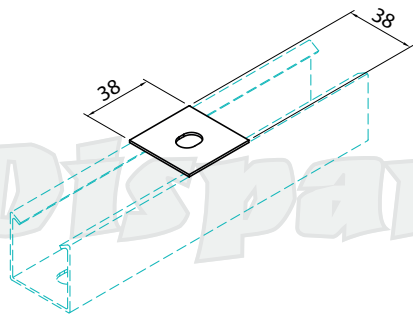

Tala simples c/ 2 furos

Two hole plate connector

DP: 597

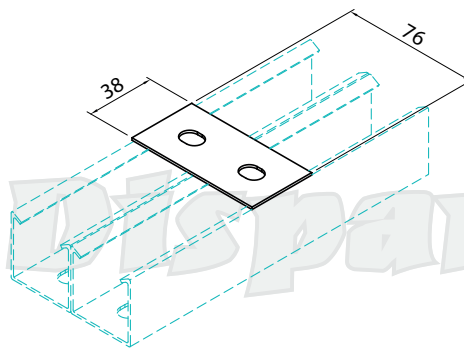

Tala simples c/ 3 furos

Three hole plate connector

DP: 598

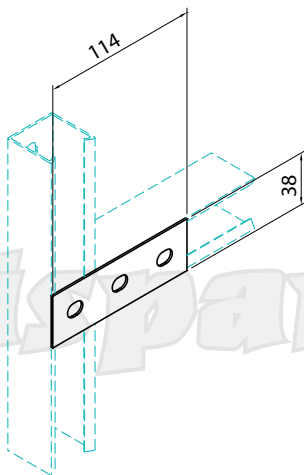

Tala simples c/ 4 furos

Four hole plate connector

DP: 599

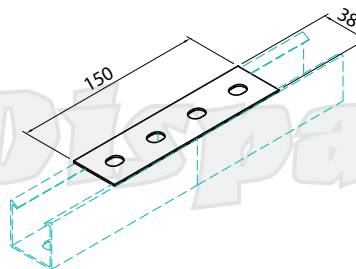

Tala simples c/ 5 furos

Five hole plate connector

DP: 600

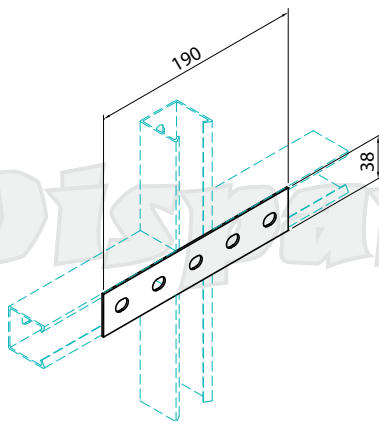

Tala simples c/ 6 furos

Six hole plate connector

DP: 601

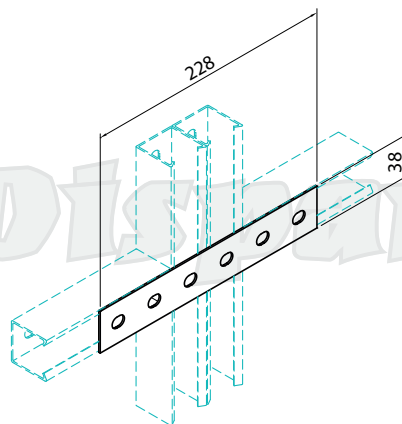

**Curva vertical interna 90° p/
perfilado 38x38mm**
90° internal vertical bend for channel 38x38 mm

DP: 602

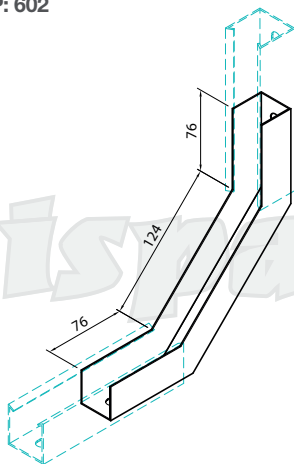

**Curva horizontal 90° p/ perfilado
38x38mm**

90° horizontal bend for channel 38x38 mm

DP: 603

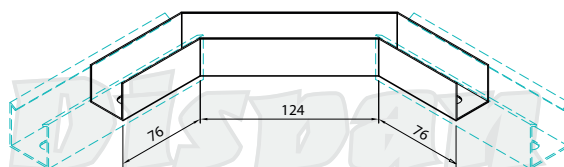

**Curva vertical externa 90° p/
perfilado 38x38mm**
90° external vertical bend for channel 38x38 mm

DP: 604

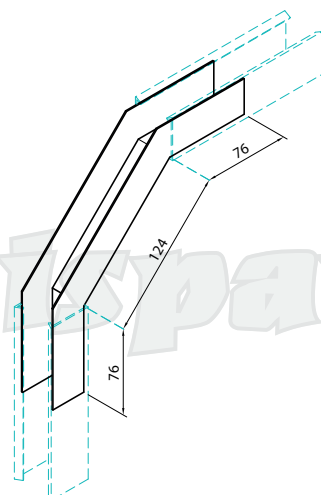

**Curva de inversão 90° p/ perfilado
38x38mm**

90° reversal vertical bend for channel 38x38 mm

DP: 605

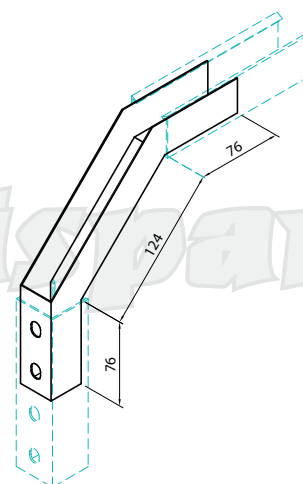

**Desnível vertical p/ perfilado
38x38mm**
Vertical crossover for channel 38x38 mm

DP: 606

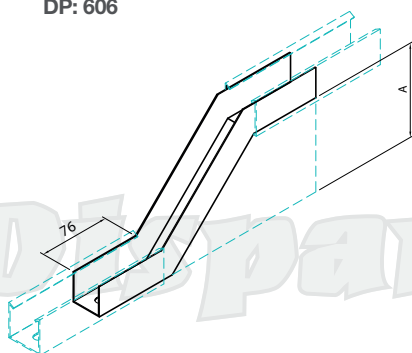

Obs: Indicar cota A.

**Desvio horizontal à direita p/
perfilado 38x38mm**
Right horizontal crossover for channel 38x38 mm

DP: 607-D

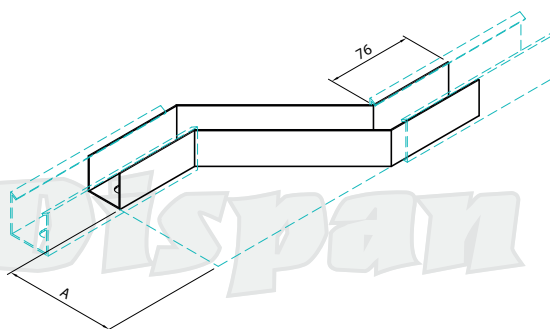

Obs: Indicar cota A.

**Desvio horizontal à esquerda p/
perfilado 38x38mm**
Left horizontal crossover for channel 38x38 mm

DP: 607-E

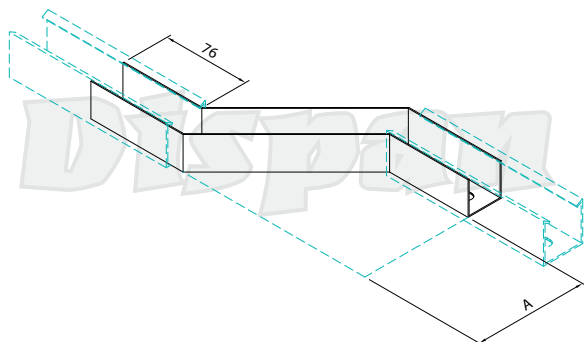

**Curva vertical interna 45° p/
perfilado 38x38mm**
45° internal vertical bend for channel 38x38 mm

DP: 641

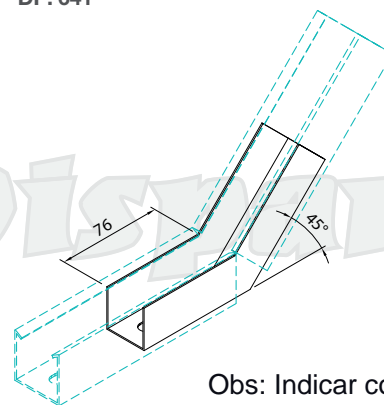

Obs: Indicar cota A.

**Curva horizontal 45° p/ perfilado
38x38mm**
45° horizontal bend for channel 38x38 mm

DP: 642

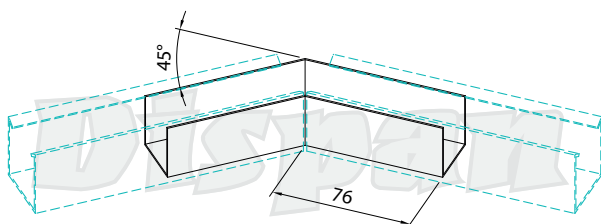

**Curva vertical externa 45° p/
perfilado 38x38mm**
45° external vertical bend for channel 38x38 mm

DP: 643

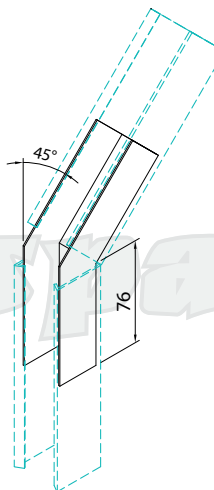

**Curva vertical interna 90° p/
perfilado 38x76mm**
90° internal vertical bend for channel 38x76 mm

DP: 644

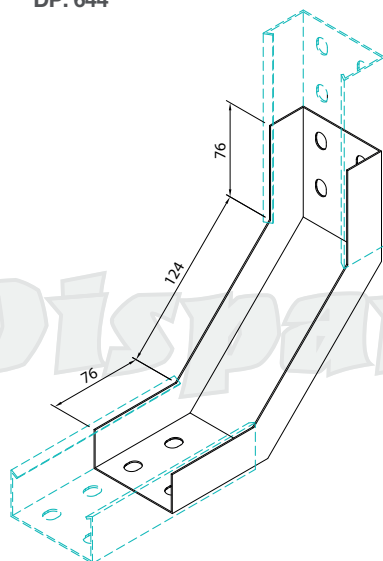

**Curva horizontal 90° p/ perfilado
38x76mm**
90° horizontal bend for channel 38x76 mm

DP: 645

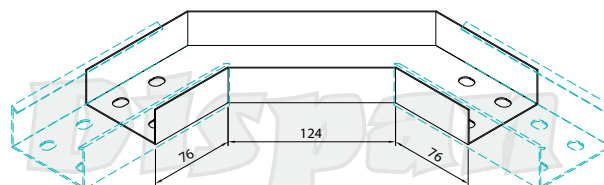

**Curva vertical externa 90° p/
perfilado 38x76mm**
90° external vertical bend for channel 38x76 mm

DP: 646

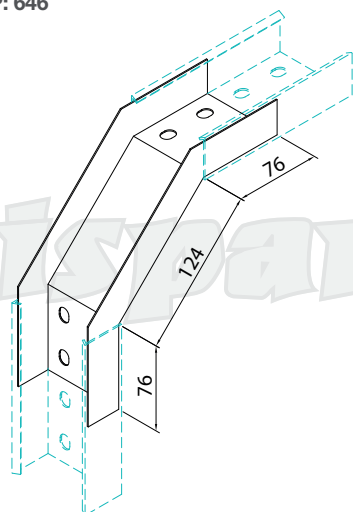

**Curva de inversão 90° p/ perfilado
38x76mm**
90° reversal vertical bend for channel 38x76 mm

DP: 647

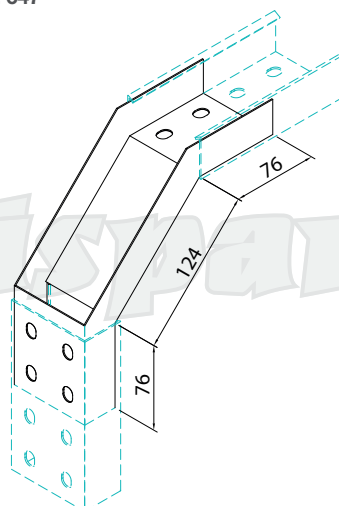

**Desnível vertical p/ perfilado
38x76mm**
Vertical crossover for channel 38x76 mm

DP: 648



**Desvio horizontal à direita p/
perfilado 38x76mm**
Right horizontal crossover for channel 38x76 mm

DP: 649

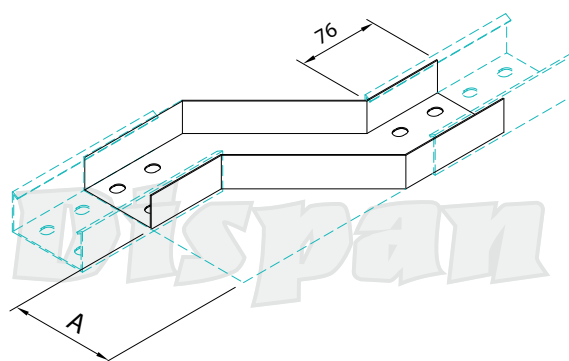

Obs: Indicar cota A.

**Desvio horizontal à esquerda p/
perfilado 38x76mm**
Left vertical crossover for channel 38x76 mm

DP: 650

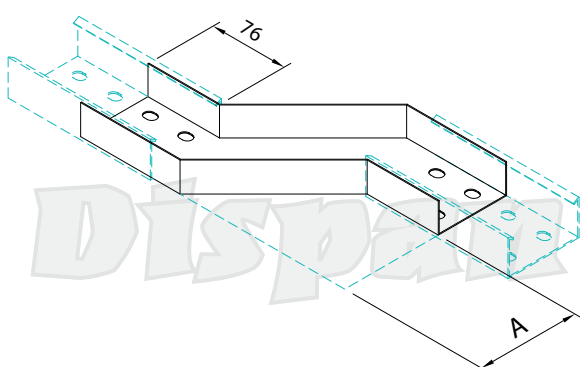

Obs: Indicar cota A.

**Curva vertical interna p/ perfilado
38x76mm**
45° internal vertical bend for channel 38x76 mm

DP: 651

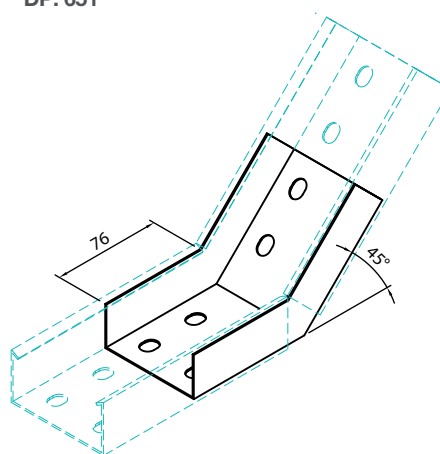

Curva horizontal 45° p/ perfilado 38x76mm

45° horizontal bend for channel 38x76 mm

DP: 652

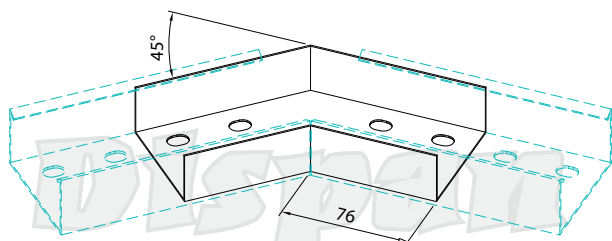

Curva vertical externa 45° p/ perfilado 38x76mm

45° external vertical bend for channel 38x76 mm

DP: 653

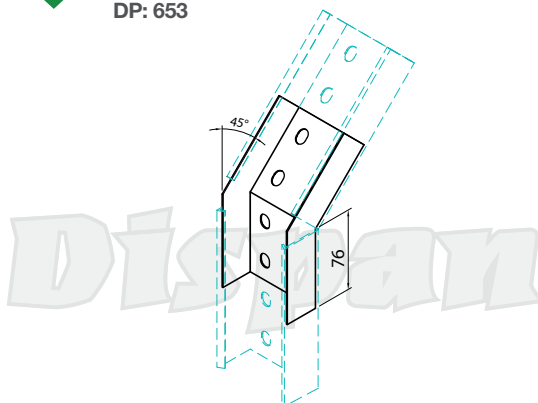

Vergalhão rosca total

Continuous threaded rod

DP: 608



Tabela de carga	
Diâmetros de vergalhão	Carga máxima
Vergalhão 1/4"	Kg 450
Vergalhão 5/16"	Kg 600
Vergalhão 3/8"	Kg 920
Vergalhão 1/2"	Kg 1250

Parafuso olhal

Eyelet screw

DP: 609

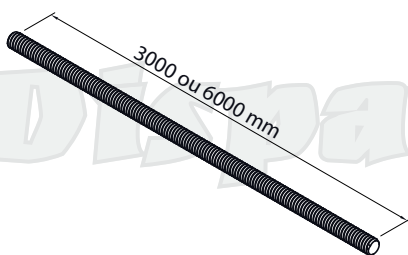

Tabela de carga.	
Diâmetros de paraf. olha	Carga máxima
Olhal de 1/4"	Kg 90
Olhal de 3/8"	Kg 150

Prolongador p/ vergalhão

Hanger rod extension

DP: 610

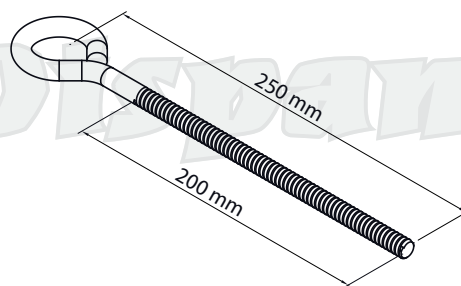

Tabela de carga.	
Diâmetros de prolongador	Carga máxima
Prolongador 1/4"	Kg 450
Prolongador 5/16"	Kg 600
Prolongador 3/8"	Kg 920
Prolongador 1/2"	Kg 1250

Grapa fixa

Guide saddle

DP: 611

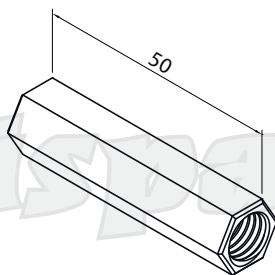
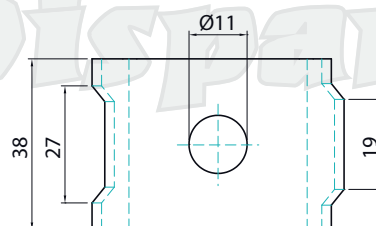
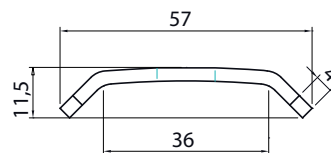

Como solicitar parafusos, braçadeiras e etc. How to specify screw, clamps...

DP 612 - Parafuso lentilha com fenda. *Slotted lentil screw*

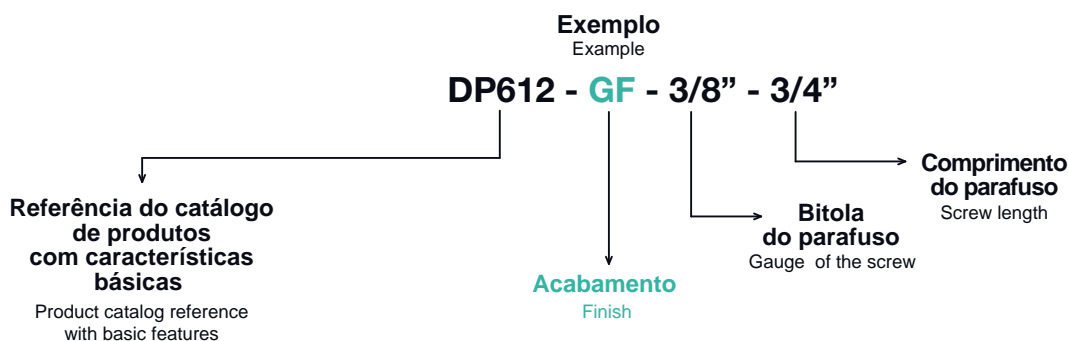
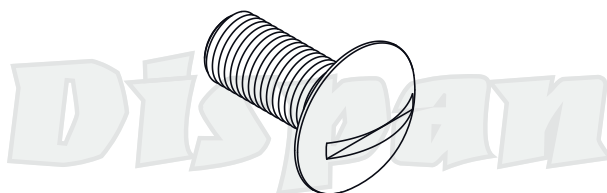

Obs: Parafusos, porcas e arruelas disponíveis apenas nos acabamentos GF / GE / IN / BC.

DP 623 - Porca losangular com pino *Lozenge nut with pin*

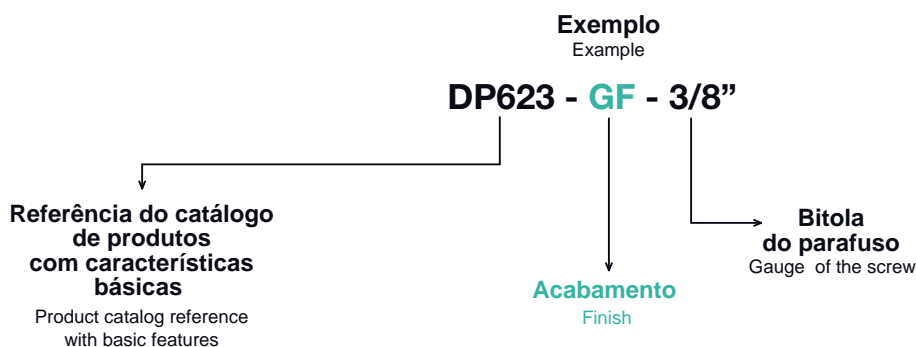
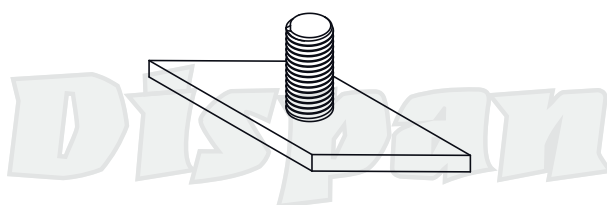

Nota

Ocasionalmente podem ocorrer algumas distorções de medidas em nossas peças, por diversos fatores. Por este motivo damos uma tolerância de 5,0 mm entre as medidas mencionadas no catálogo e as peças reais. Os furos oblongos são feitos exatamente para compensação e ajuste de eventuais diferenças.

Note

Occasionally, it may occur some distortion of measures in our pieces, for several reasons. Because of this, we give a toleration of 5.0 mm between the measures mentioned in this catalog and the real pieces. The slotted holes are made just for clearing and settling of any possible differences.

Fixação de leito com grapa fixa 3/8"

Fastening with guide saddle

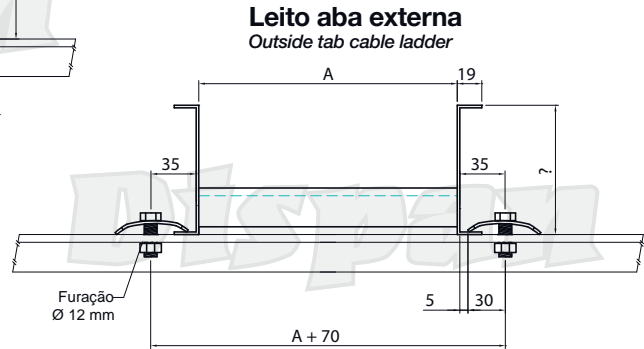
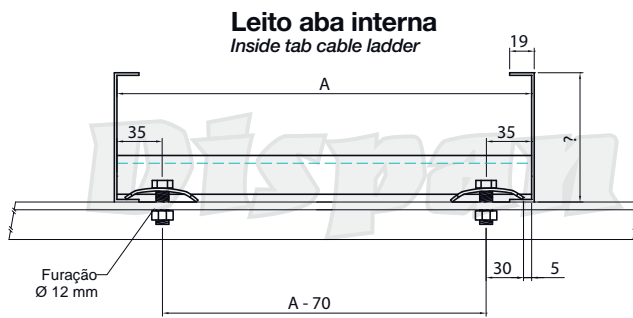

Parafuso cabeça lentilha c/ fenda

"Lentil" - type head screw

DP: 612

Rosca	Comprimento
1/4"	1/2"
1/4"	5/8"
1/4"	3/4"
5/16"	3/4"
3/8"	3/4"

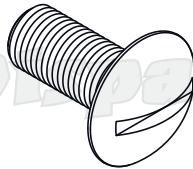

Parafuso cabeça lentilha autotravante

"Lentil" - type head screw |

DP: 613

Rosca	Comprimento
1/4"	1/2"
1/4"	5/8"
1/4"	3/4"
5/16"	3/4"
3/8"	3/4"

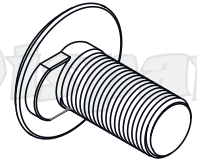

Parafuso cabeça sextavada

Hex screw

DP: 614

Rosca	Comprimento
1/4"	1/2"
	3/4"
5/16"	1"
	1.1/2"
3/8"	2"
	2.1/2"
	3"

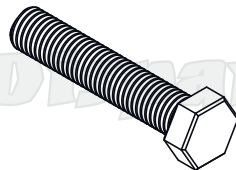

Parafuso cabeça redonda c/ fenda

Round head screw

DP: 615

Rosca	Comprimento
1/4"	1/2"
	3/4"
5/16"	1"
	1.1/2"
3/8"	2"
	2.1/2"
	3"

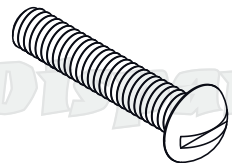

**Parafuso cabeça redonda c/ fenda
rosca soberba p/ bucha**

Round head screw with conical thread |

DP: 616

Bucha	Dimensões
S - 6	3,9 x 32
S - 8	4,8 x 38
S - 10	6,3 x 50

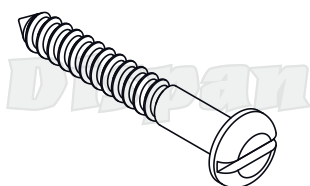

**Parafuso cabeça sextavada
rosca soberba p/ bucha**

Hex head screw with conical thread |

DP: 617

Bucha	Dimensões
S - 8	4,8 x 32
S - 10	1/4" x 50
S - 12	5/16" x 50

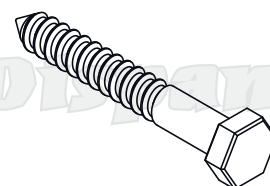

Porca sextavada

Nut

DP: 618

Rosca
1/4"
5/16"
3/8"
1/2"

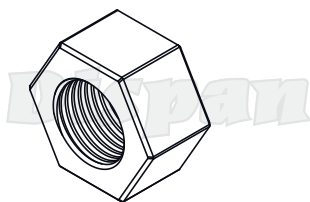

Arruela lisa

Plain washer

DP: 619

Rosca
1/4"
5/16"
3/8"
1/2"



Arruela de pressão

Lock washer

DP: 620

Rosca
1/4"
5/16"
3/8"
1/2"

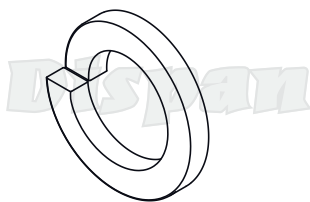

Porca losangular s/ mola

Lozengular nut

DP: 621

Rosca	Carga máx. em Kg.
1/4"	120 Kg
5/16"	210 Kg
3/8"	450 Kg
1/2"	500 Kg

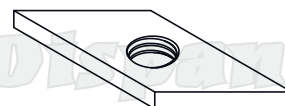

Porca losangular c/ mola

Lozengular nut with spring

DP: 622

Rosca	Carga máx. em Kg.
1/4"	120 Kg
5/16"	210 Kg
3/8"	450 Kg
1/2"	500 Kg

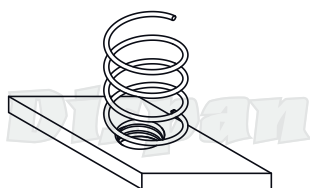

Porca losangular c/ pino

Lozengular stud nut

DP: 623

Rosca	Carga máx. em Kg.
1/4"	120 Kg
5/16"	210 Kg
3/8"	450 Kg
1/2"	500 Kg

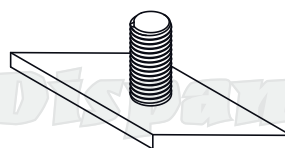

Bucha de nylon

Nylon cinchanchor for concrete insert

DP: 624N

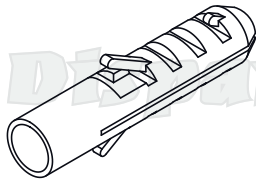

Rosca	Ø Broca p/ furo	Carga máx. em Kg.
S - 6	1/4" - 6 mm	25 Kg
S - 8	5/16" - 8 mm	50 Kg
S - 10	3/8" - 10 mm	75 Kg
S - 12	1/2" - 12 mm	100 Kg

Bucha de plástico

Plastic cinchanchor for concrete insert

DP: 624P

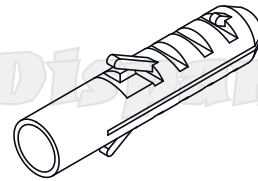

Rosca	Ø Broca p/ furo	Carga máx. em Kg.
S - 6	1/4" - 6 mm	16 Kg
S - 8	5/16" - 8 mm	35 Kg
S - 10	3/8" - 10 mm	60 Kg
S - 12	1/2" - 12 mm	80 Kg

Chumbador "CB" completo

Complete anchor bolt

DP: 625

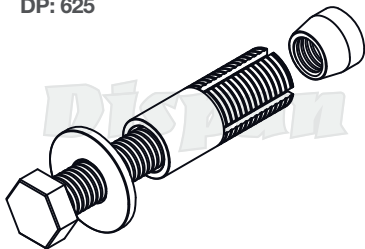

Rosca	Compr. s/ paraf.	Broca	Carga máx. em Kg
1/4"	35 mm	10 mm	1300 Kg
5/16"	38 mm	12 mm	1550 Kg
3/8"	40 mm	14 mm	2100 Kg

Chumbador "CB" sem parafuso

Anchor bolt with internal thread

DP: 625CJ

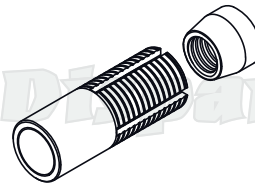

Rosca	Compr. s/ paraf.	Broca	Carga máx. em Kg
1/4"	35 mm	10 mm	1300 Kg
5/16"	38 mm	12 mm	1550 Kg
3/8"	40 mm	14 mm	2100 Kg

Chumbador "URX"

Anchor bolt with external thread

DP: 626

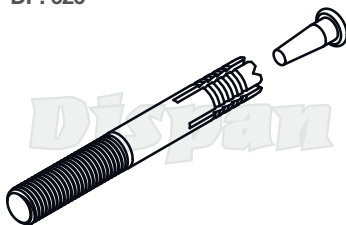

Rosca	Compr. total	Compr. rosca	Carga máx. em Kg.
1/4"	56 mm	30 mm	900 Kg
3/8"	75 mm	30 mm	1800 Kg

Batedor "URX"

Beater "URX"

DP: 627

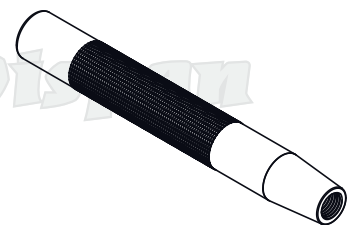

Rosca
1/4"
3/8"

Chumbador "UR"

Internal - thread anchor bolt

DP: 628

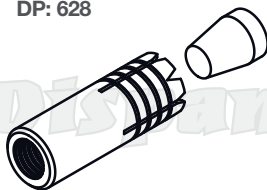

Rosca	Compr. total	Broca	Carga máx. em Kg.
1/4"	35 mm	10 mm	900 Kg
3/8"	40 mm	14 mm	1800 Kg

Batedor "UR"

Beater "UR"

DP: 629

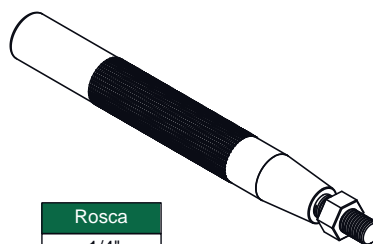

Rosca
1/4"
3/8"

Grampo

DP: 641

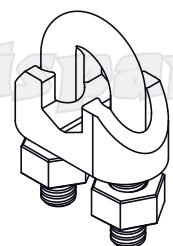

Disponível para cabo de aço 1/8" e 3/16".

Braçadeira "D" com cunha
"D" pipe clamp

DP: 630

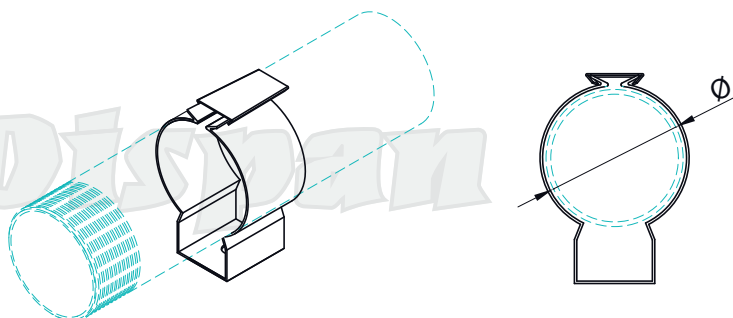

Referência	Ø Nominal
630 - 1	1/2"
630 - 2	3/4"
630 - 3	1"
630 - 4	1.1/4"
630 - 5	1.1/2"
630 - 6	2"
630 - 7	2.1/2"
630 - 8	3"
630 - 9	3.1/2"
630 - 10	4"

Braçadeira "U" perfil c/ parafuso
"U" pipe clamp

DP: 631

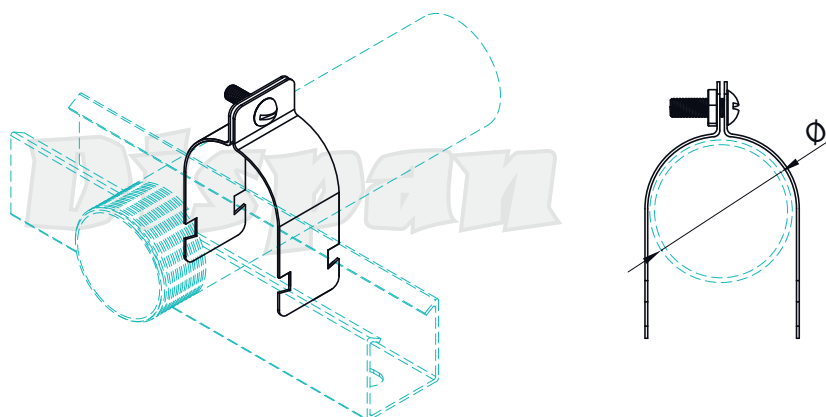

Referência	Ø Nominal
631 - 1	1/2"
631 - 2	3/4"
631 - 3	1"
631 - 4	1.1/4"
631 - 5	1.1/2"
631 - 6	2"
631 - 7	2.1/2"
631 - 8	3"
631 - 9	3.1/2"
631 - 10	4"

Braçadeira ômega
Omega clamp

DP: 632

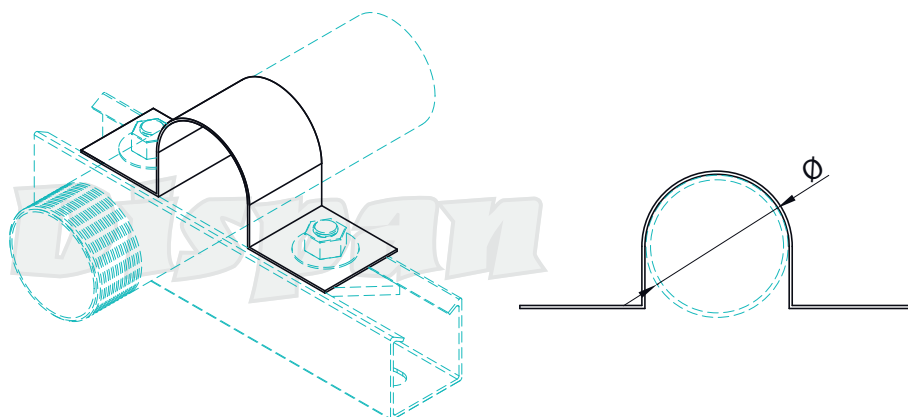

Referência	Ø Nominal
632 - 1	1/2"
632 - 2	3/4"
632 - 3	1"
632 - 4	1.1/4"
632 - 5	1.1/2"
632 - 6	2"
632 - 7	2.1/2"
632 - 8	3"
632 - 9	3.1/2"
632 - 10	4"

Braçadeira unha
Nail clamp

DP: 633

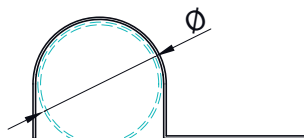
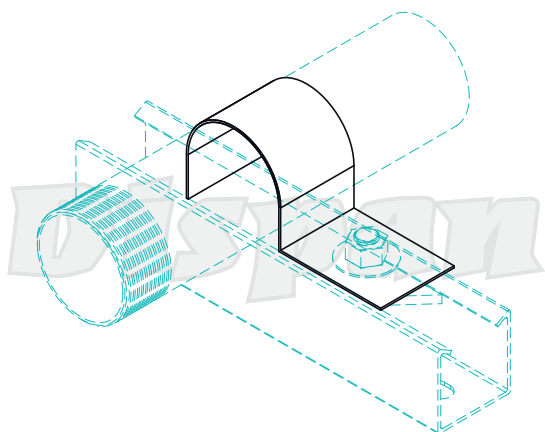

Referência	Ø Nominal
633 - 1	1/2"
633 - 2	3/4"
633 - 3	1"
633 - 4	1.1/4"
633 - 5	1.1/2"
633 - 6	2"
633 - 7	2.1/2"
633 - 8	3"
633 - 9	3.1/2"
633 - 10	4"

Braçadeira "U" de vergalão
"U" clamp

DP: 634

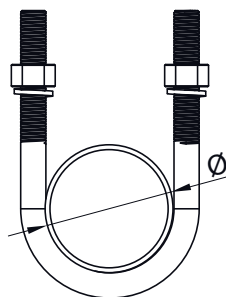
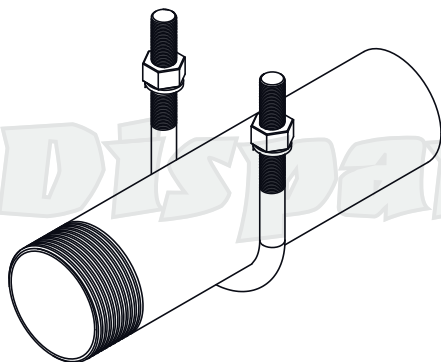

Referência	Ø Nominal	Carga Máx.
634 - 1	1/2"	200 Kg
634 - 2	3/4"	350 Kg
634 - 3	1"	350 Kg
634 - 4	1.1/4"	350 Kg
634 - 5	1.1/2"	350 Kg
634 - 6	2"	350 Kg
634 - 7	2.1/2"	500 Kg
634 - 8	3"	500 Kg
634 - 9	3.1/2"	500 Kg
634 - 10	4"	500 Kg
634 - 11	5"	500 Kg
634 - 12	6"	500 Kg
634 - 13	8"	900 Kg
634 - 14	10"	900 Kg
634 - 15	12"	900 Kg

Braçadeira econômica
Bend hanger economic - type

DP: 635

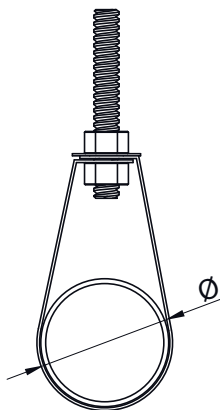
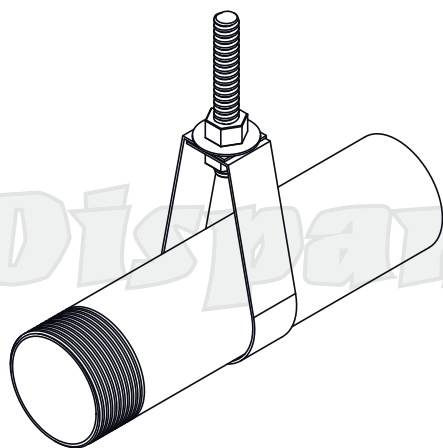

Referência	Ø Nominal	Carga Máx.
635 - 1	1/2"	200 Kg
635 - 2	3/4"	200 Kg
635 - 3	1"	200 Kg
635 - 4	1.1/4"	200 Kg
635 - 5	1.1/2"	200 Kg
635 - 6	2"	250 Kg
635 - 7	2.1/2"	250 Kg
635 - 8	3"	250 Kg
635 - 9	3.1/2"	250 Kg
635 - 10	4"	250 Kg
635 - 11	5"	300 Kg
635 - 12	6"	300 Kg
635 - 13	8"	300 Kg

Braçadeira união horizontal

Adjustable hanger horizontal type

DP: 636

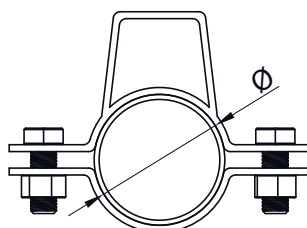
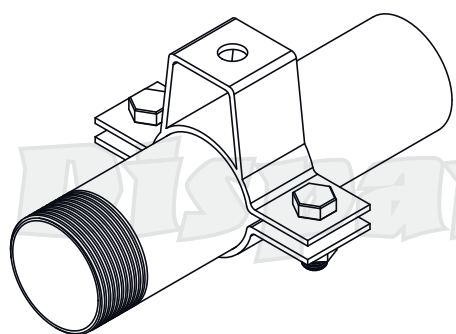

Referência	Ø Nominal	Carga Máx.
636 - 1	1/2"	200 Kg
636 - 2	3/4"	200 Kg
636 - 3	1"	200 Kg
636 - 4	1.1/4"	250 Kg
636 - 5	1.1/2"	250 Kg
636 - 6	2"	250 Kg
636 - 7	2.1/2"	250 Kg
636 - 8	3"	250 Kg
636 - 9	3.1/2"	250 Kg
636 - 10	4"	250 Kg
636 - 11	5"	300 Kg
636 - 12	6"	300 Kg
636 - 13	8"	300 Kg
636 - 14	10"	300 Kg
636 - 15	12"	300 Kg

Braçadeira união vertical

Adjustable hanger vertical type

DP: 637

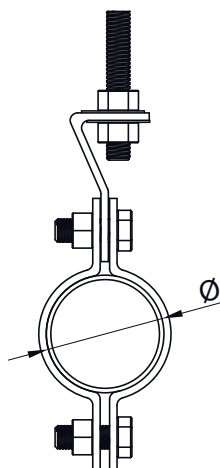
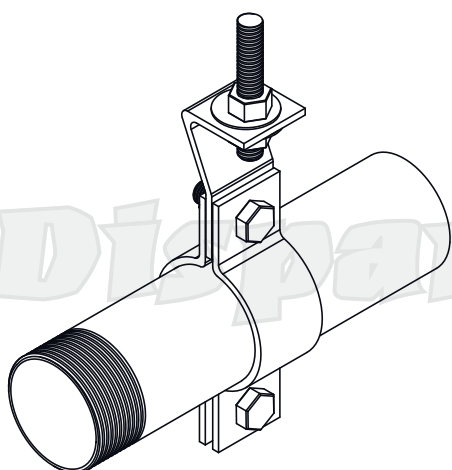

Referência	Ø Nominal	Carga Máx.
637 - 1	3/4"	200 Kg
637 - 2	1/2"	200 Kg
637 - 3	1"	200 Kg
637 - 4	1.1/4"	250 Kg
637 - 5	1.1/2"	250 Kg
637 - 6	2"	250 Kg
637 - 7	2.1/2"	250 Kg
637 - 8	3"	250 Kg
637 - 9	3.1/2"	250 Kg
637 - 10	4"	250 Kg
637 - 11	5"	300 Kg
637 - 12	6"	300 Kg
637 - 13	8"	300 Kg
637 - 14	10"	300 Kg
637 - 15	12"	300 Kg

Grampo "C" 1/4

Small beam clamp

DP: 639

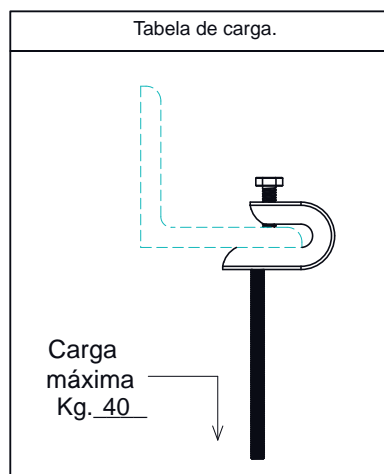
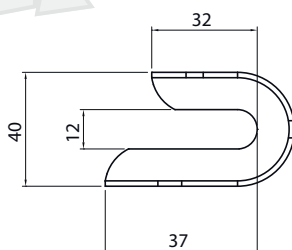
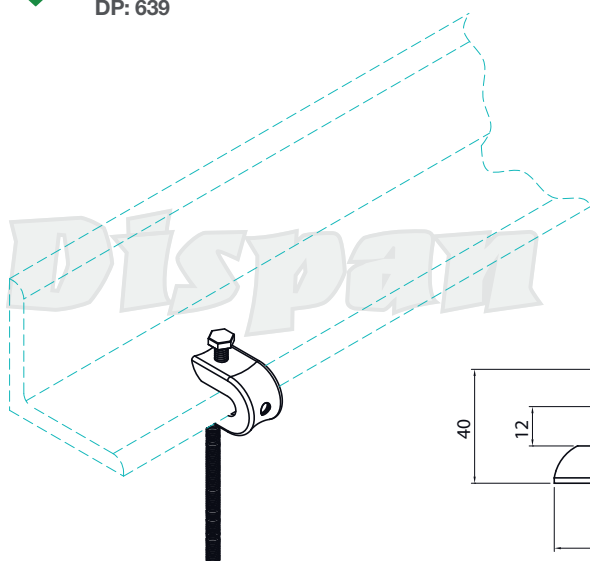

Suporte para eletroduto
Conduit support

DP: 640

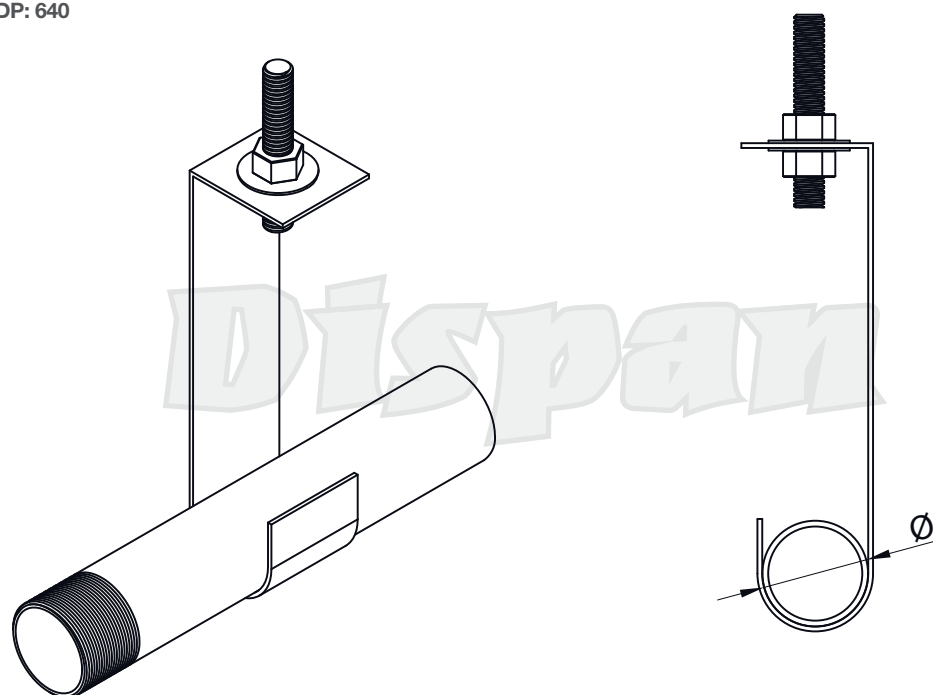

Referência	Ø Nominal	Carga Máx.
640 - 1	1/2"	60 Kg
640 - 2	3/4"	60 Kg
640 - 3	1"	60 Kg

Braçadeira "D" com parafuso
"D" pipe clamp

DP: 630P

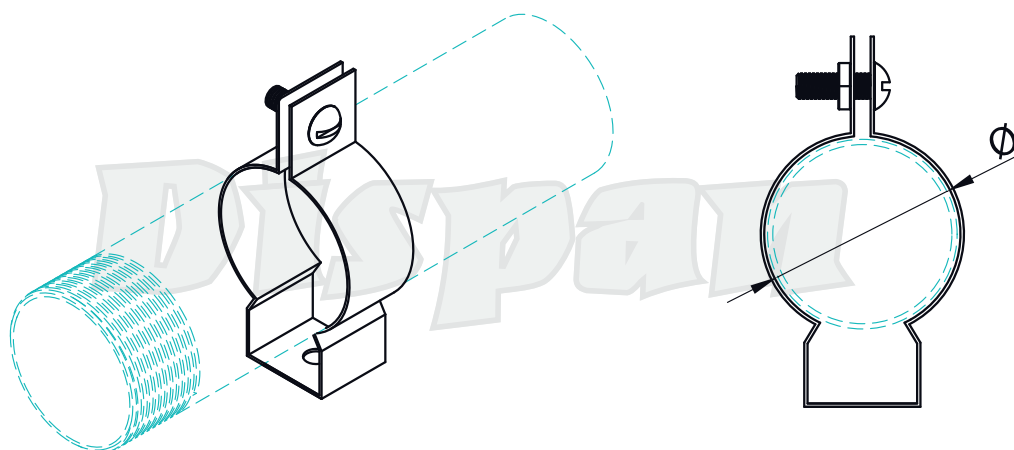

Referência	Ø Nominal
630 - 1	1/2"
630 - 2	3/4"
630 - 3	1"
630 - 4	1.1/4"
630 - 5	1.1/2"

Referência	Ø Nominal
630 - 6	2"
630 - 7	2.1/2"
630 - 8	3"
630 - 9	3.1/2"
630 - 10	4"

Demonstração de suportação

Typical applications

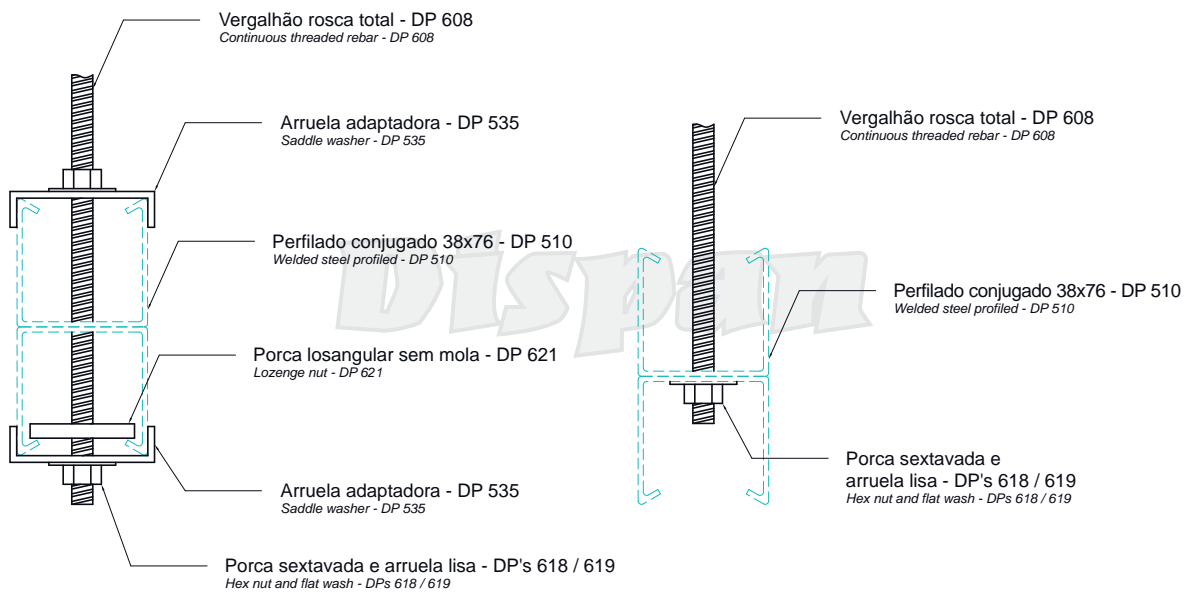
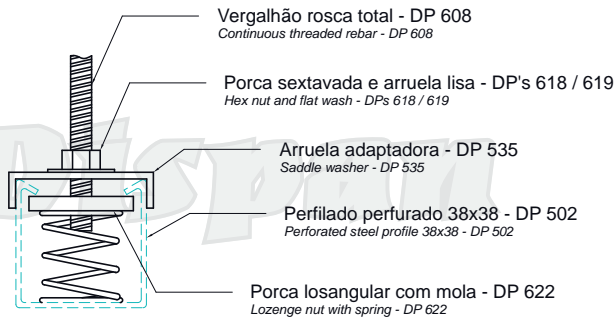
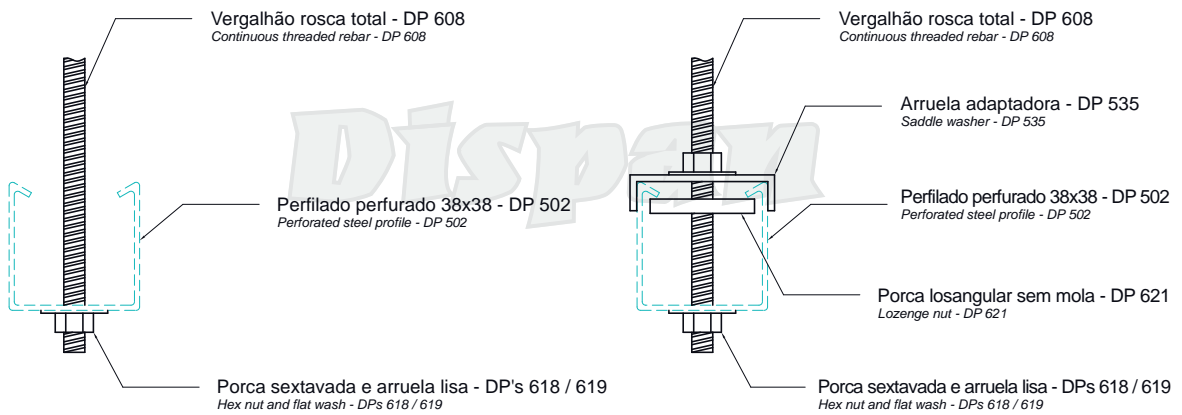

Demonstração de suportes
 Typical applications

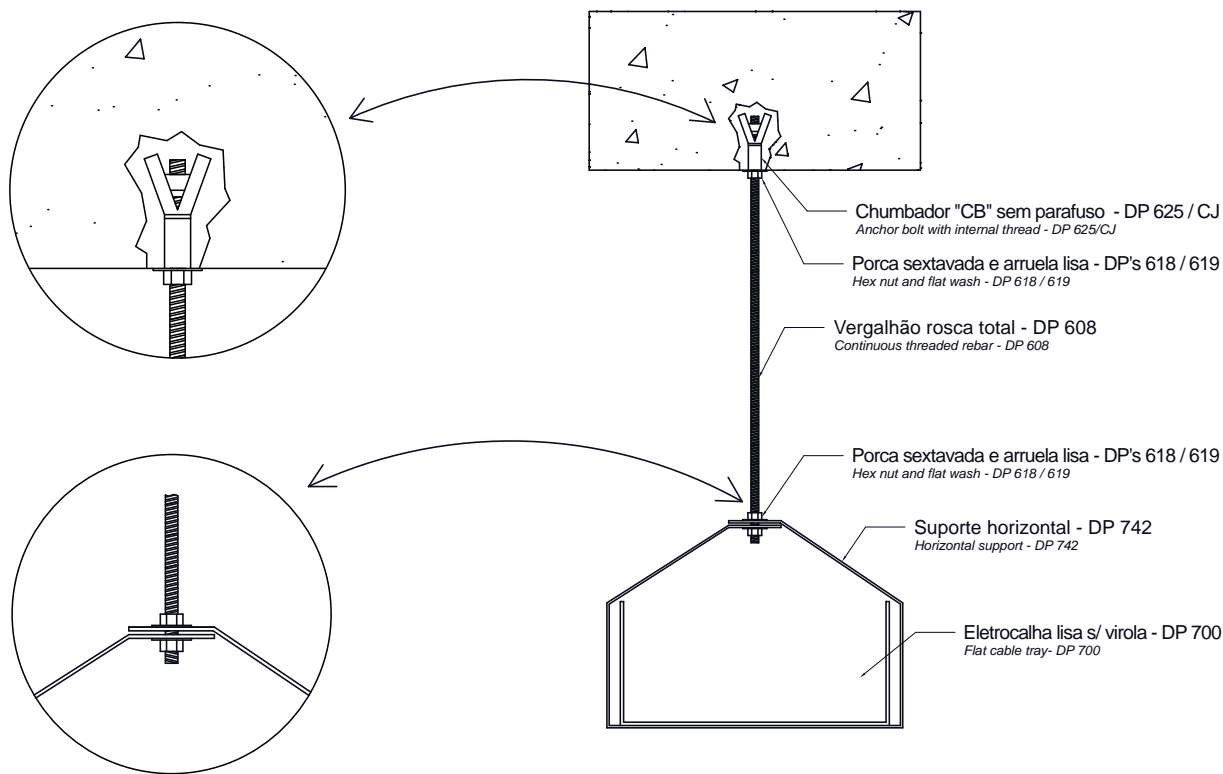
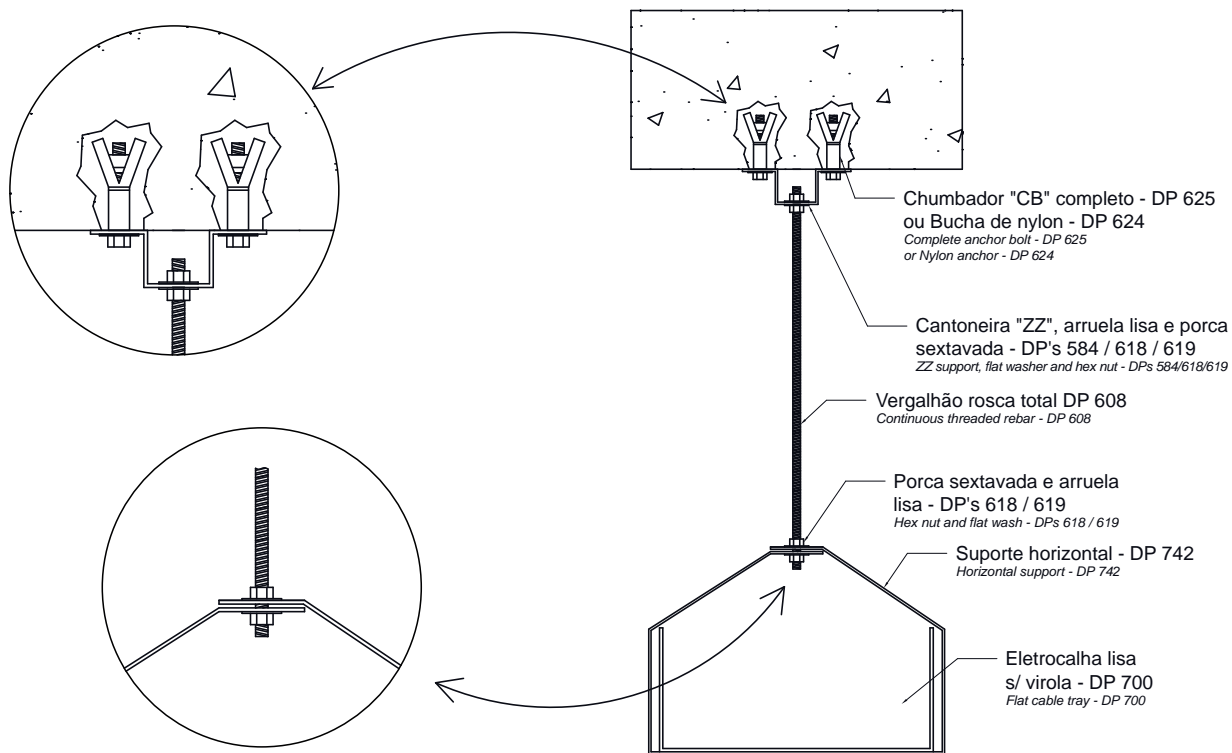

Demonstração de suportação

Typical applications

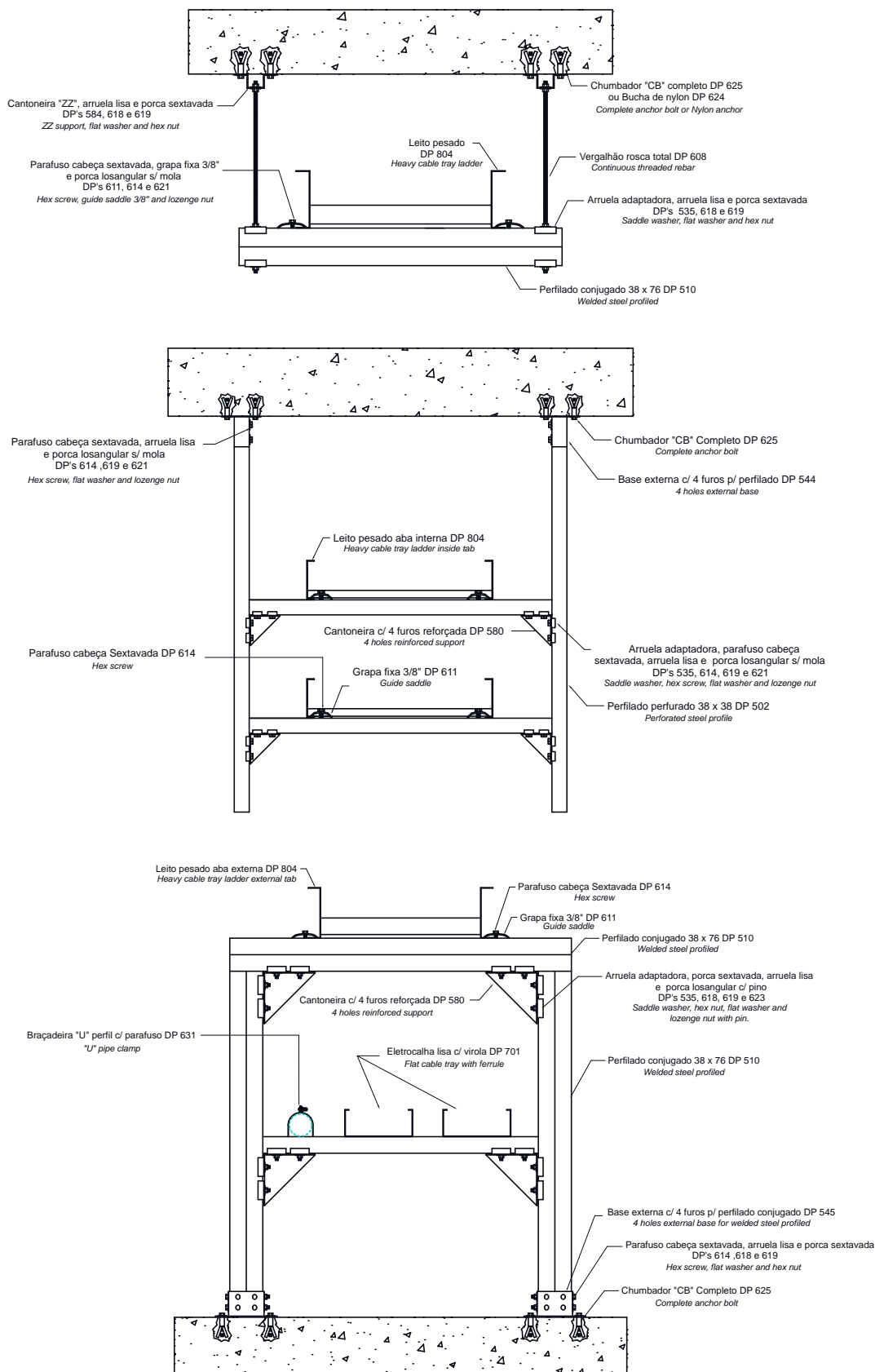

Demonstração de suportaço

Typical applications

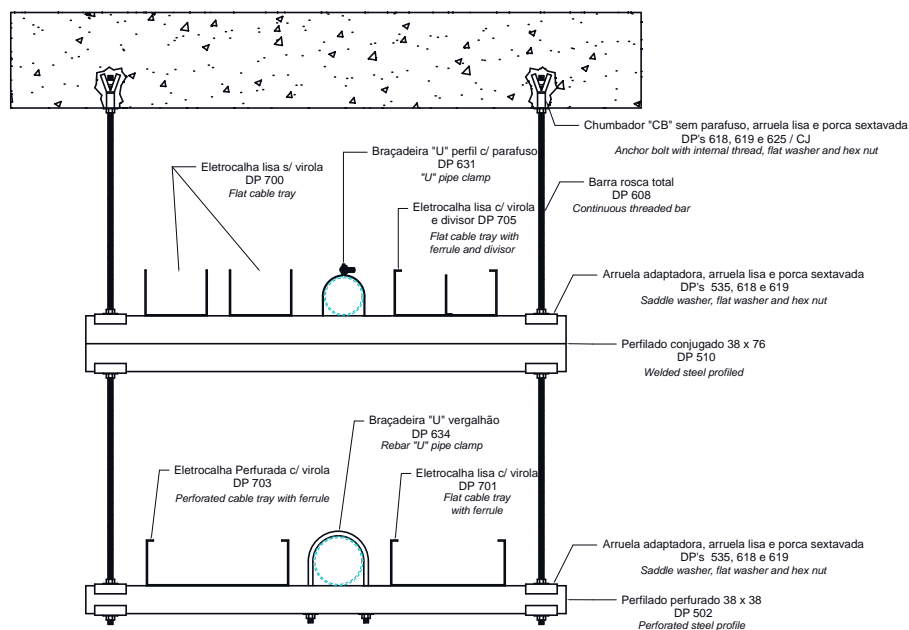
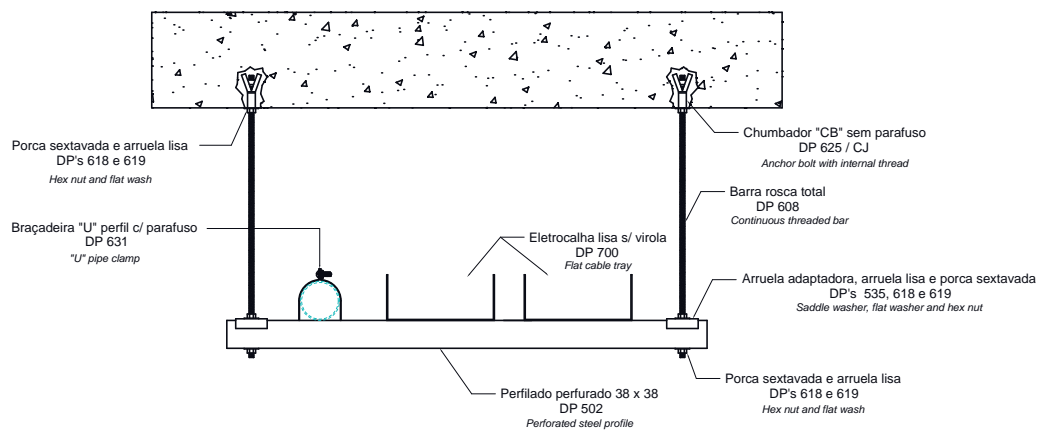
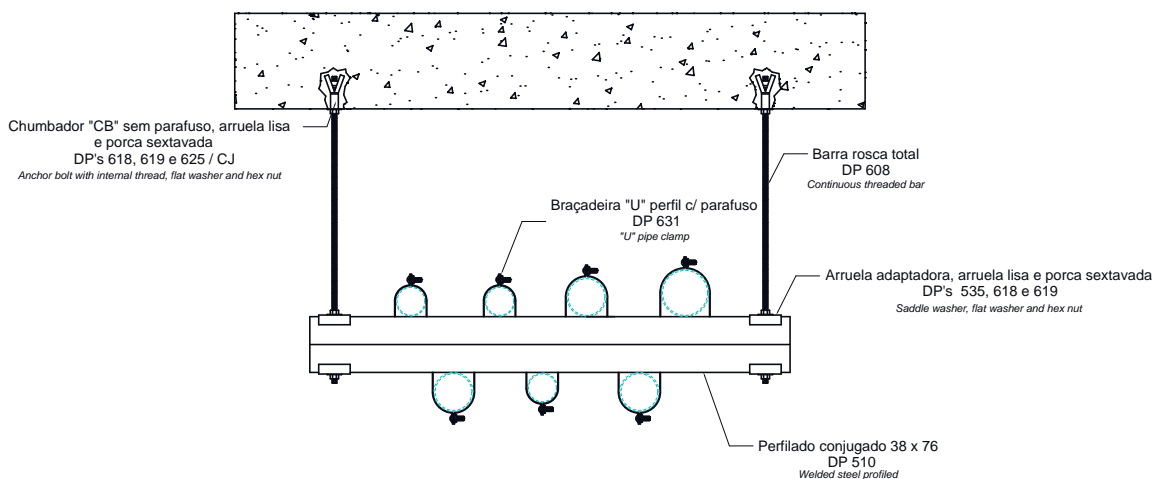

Exemplo de Carga Distribuída
Load distributed example

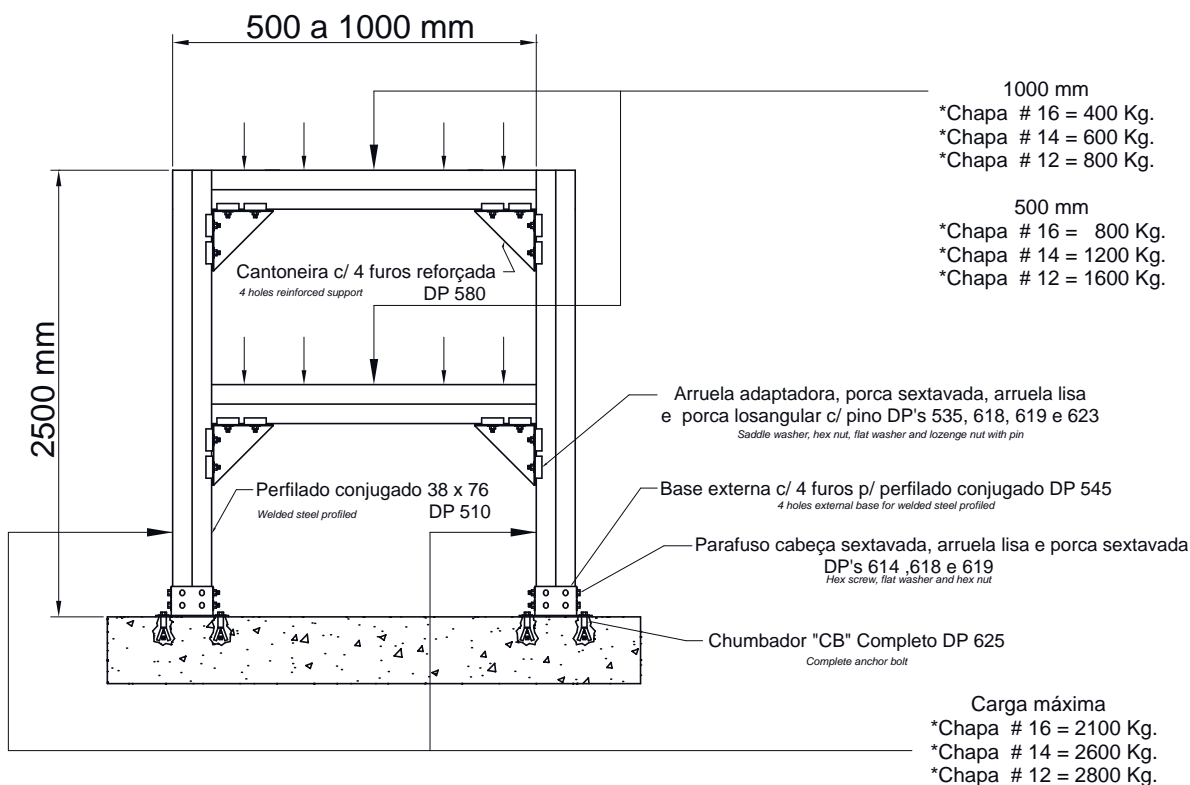
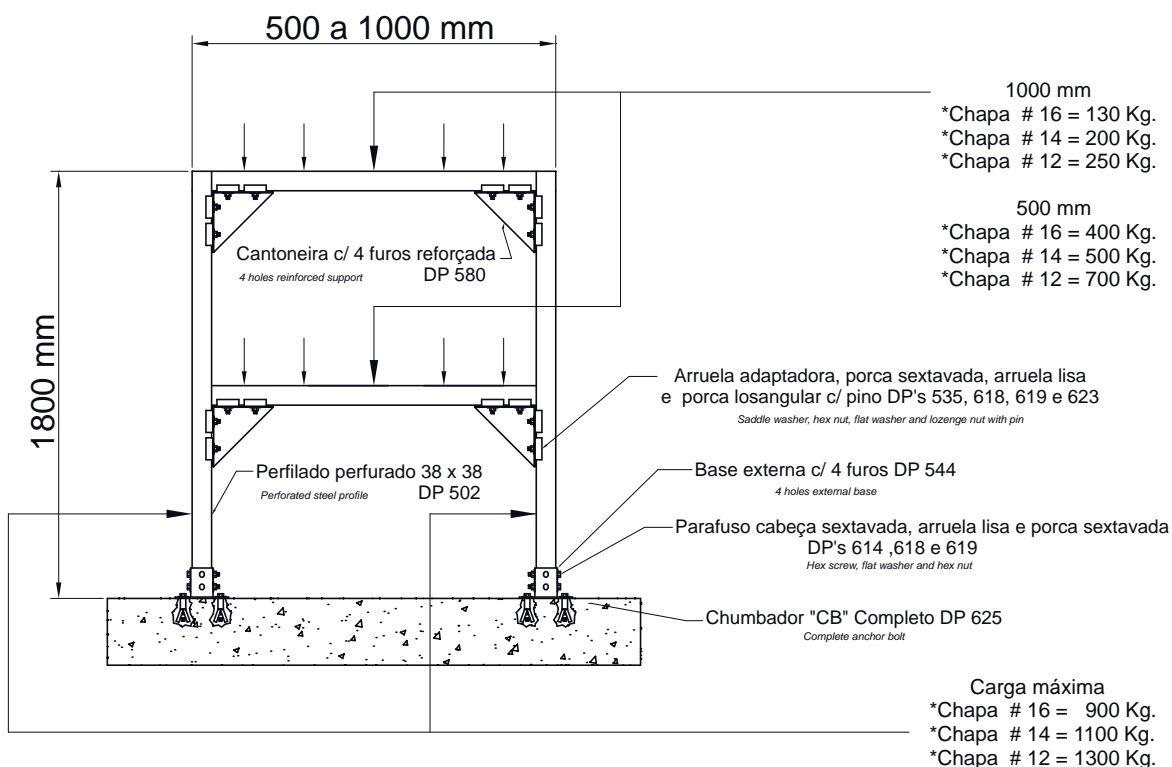

Aramados

Wire fittings

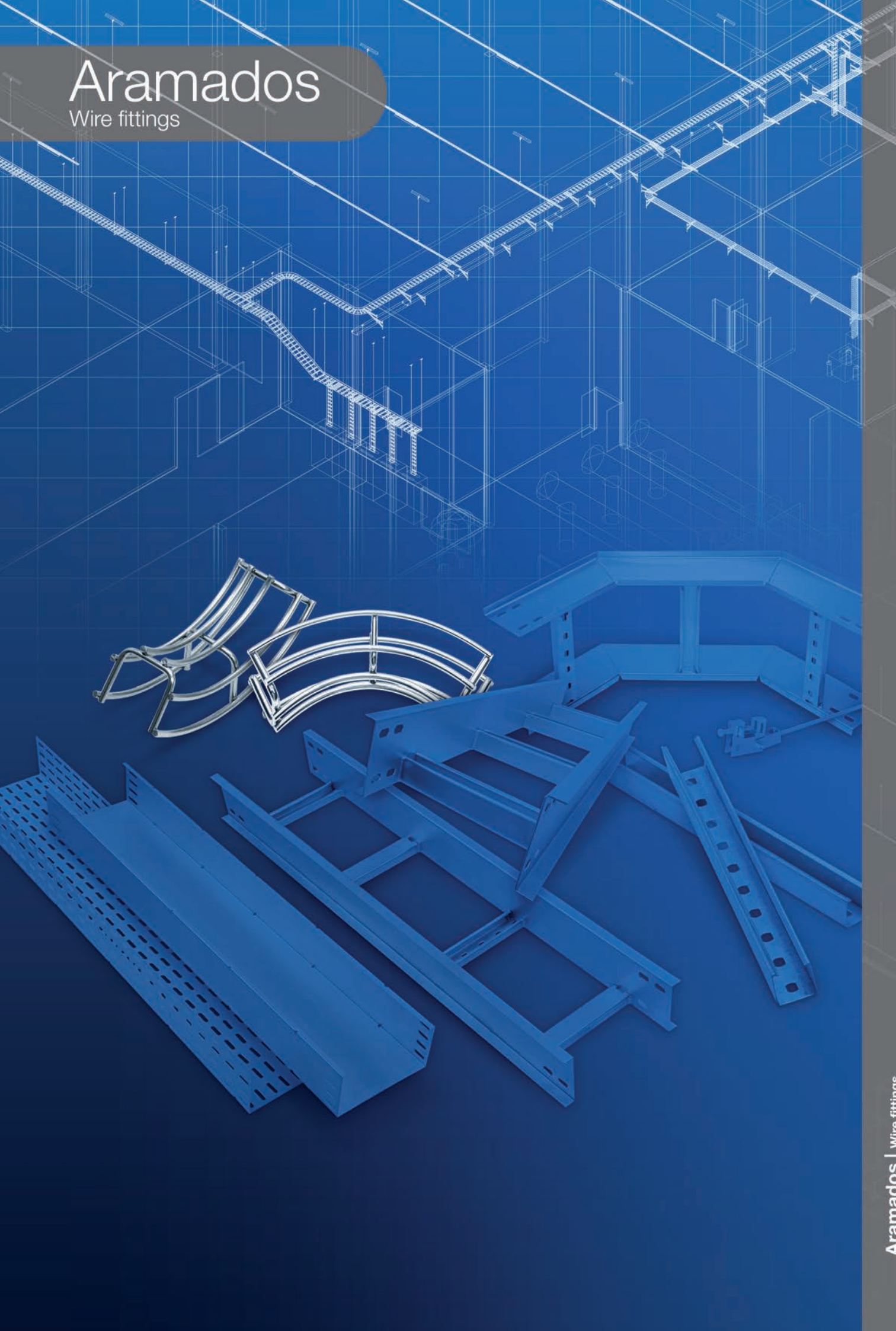

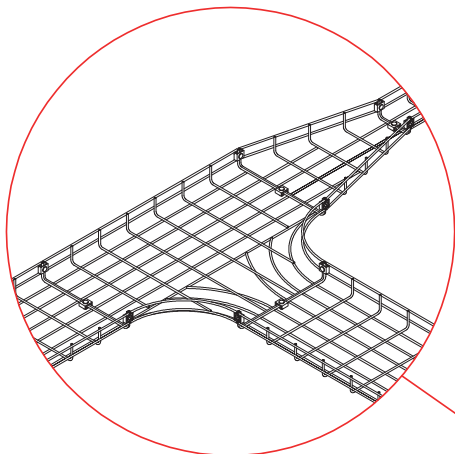

Montagem c/ te horizontal 90°
e redução concêntrica
DP's 907 e 909

*Assembling with horizontal "tee"
90° and concentric reduction DPs
907 and 909*

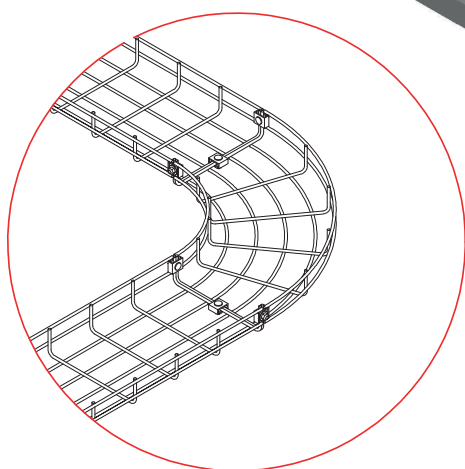
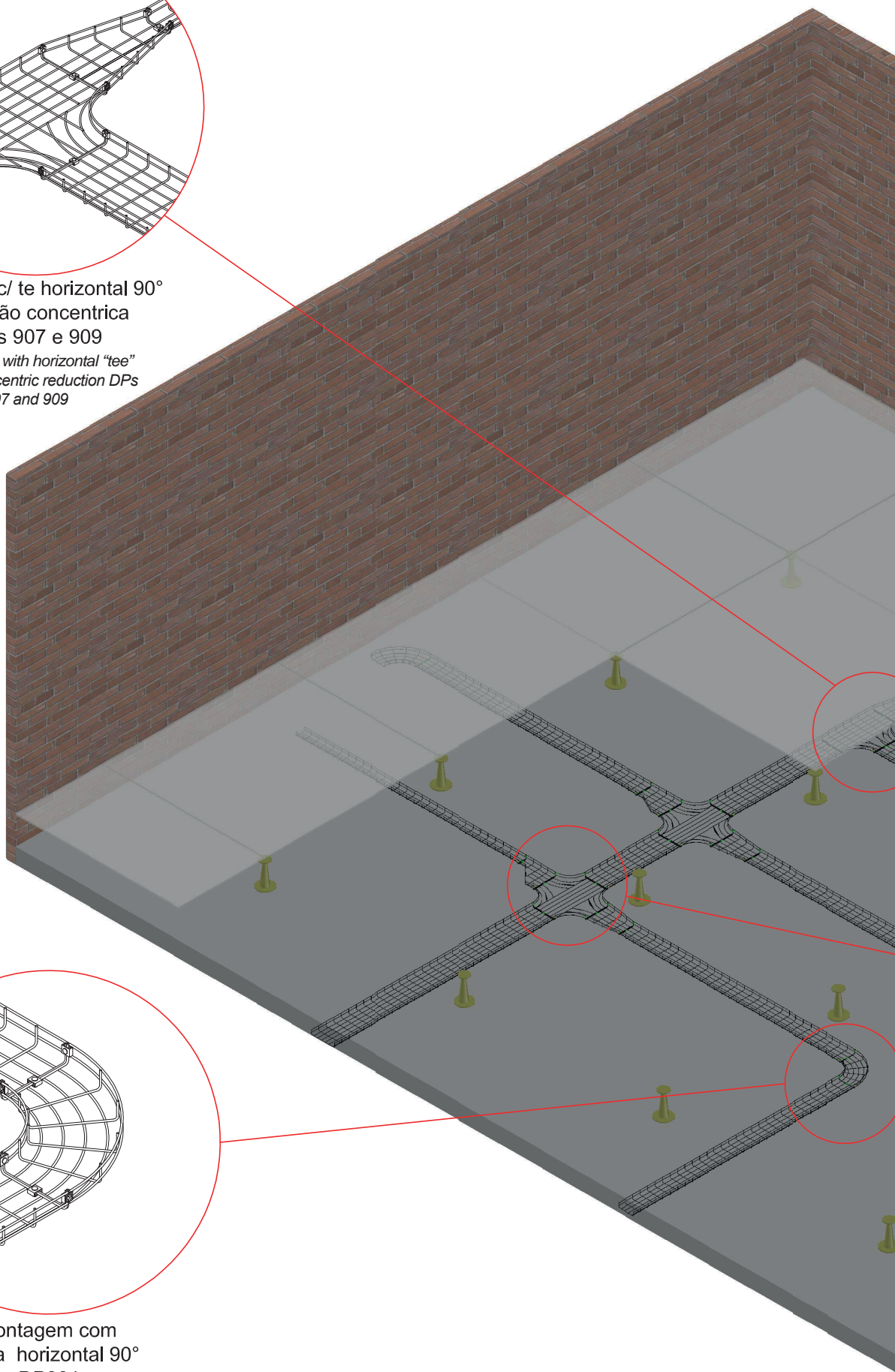

Montagem com
curva horizontal 90°
DP901

*Assembling with horizontal bend
90° DP901*

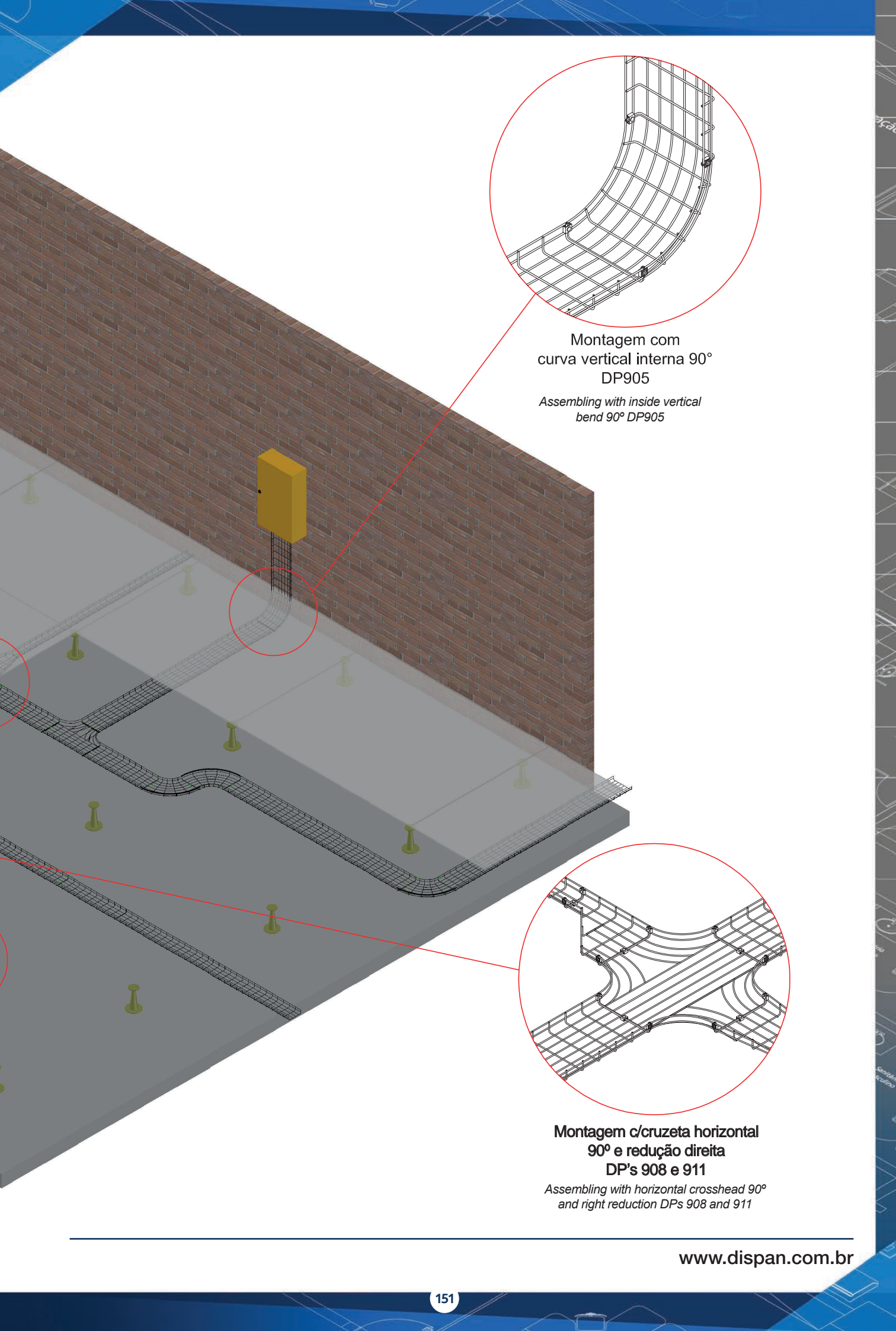

Montagem com
curva vertical interna 90°
DP905

*Assembling with inside vertical
bend 90° DP905*

Montagem c/cruzeta horizontal
90° e redução direita
DP's 908 e 911

*Assembling with horizontal crosshead 90°
and right reduction DPs 908 and 911*

Como solicitar eletrocalha aramada

How to specify connections for wire mesh cable tray.

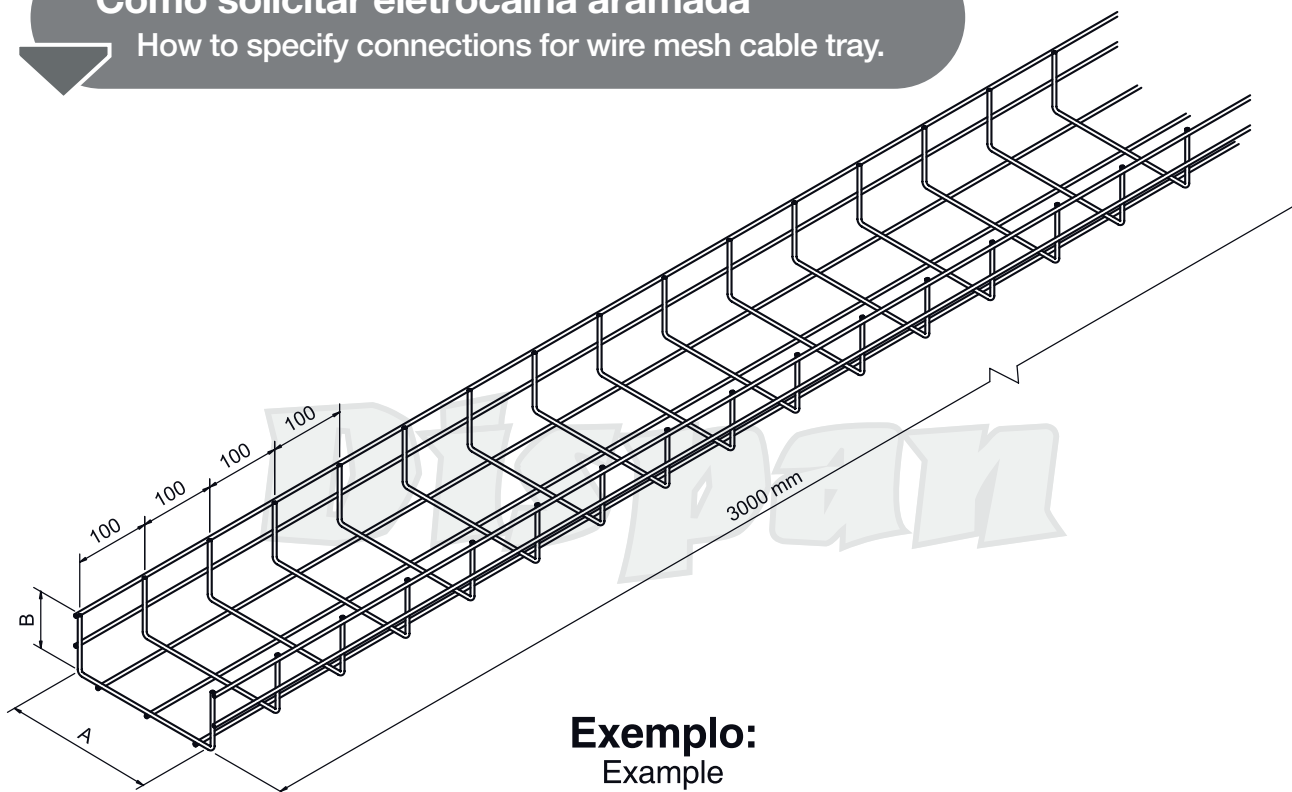

Exemplo:

Example

DP900 - AC - GF - 400/100 - 3/16"

Modelo da eletrocalha aramada.

Matéria-prima de fabricação.

Acabamento.

Largura / altura da eletrocalha.

Bitola do arame de construção da eletrocalha aramada.

DP900 - Eletrocalha aramada - Tipo leve

Matéria-prima base

AC - Aço carbono
AI - Aço inox

Acabamento aplicado na matéria-prima em base de aço carbono.

GF - Galvanizado à fogo por imersão
GE - Galvanizado eletrolítico
PT - Galvanizado e Pintado

Largura

400 - Largura da eletrocalha desejada (De 30mm a 1000mm)

Altura

100 - Altura da eletrocalha desejada (30mm / 50mm / 75mm / 100mm / 150mm)

Diâmetro da bitola dos arames.

3/16" - Bitola da eletrocalha aramada = Tipo Leve.

1/4" - Bitola da eletrocalha aramada = Tipo Pesado.

Descritivo técnico.

DP900 - Eletrocalha aramada leve, em aço carbono, galvanizado fogo, largura de 400 mm, com aba de 100 mm na bitola 3/16".

Montagem com conector curto ou reforçado.

Larguras - 50 à 75 mm = 2 Conectores.
100 à 200 mm = 3 Conectores.
300 à 1000 mm = 4 Conectores.

Nota - 1

Ocasionalmente podem ocorrer algumas distorções de medidas em nossas peças, por diversos fatores. Por este motivo damos uma tolerância de 5,0 mm entre as medidas mencionadas no catálogo e as peças reais. As peças de conexões entre as partes contêm furos oblongos para corrigir eventuais diferenças.

Leito Sanitário / Eletrocalha Aramada 3/16" Tipo Leve

Wire mesh cable tray 3/16 lightweight kind

DP: 900

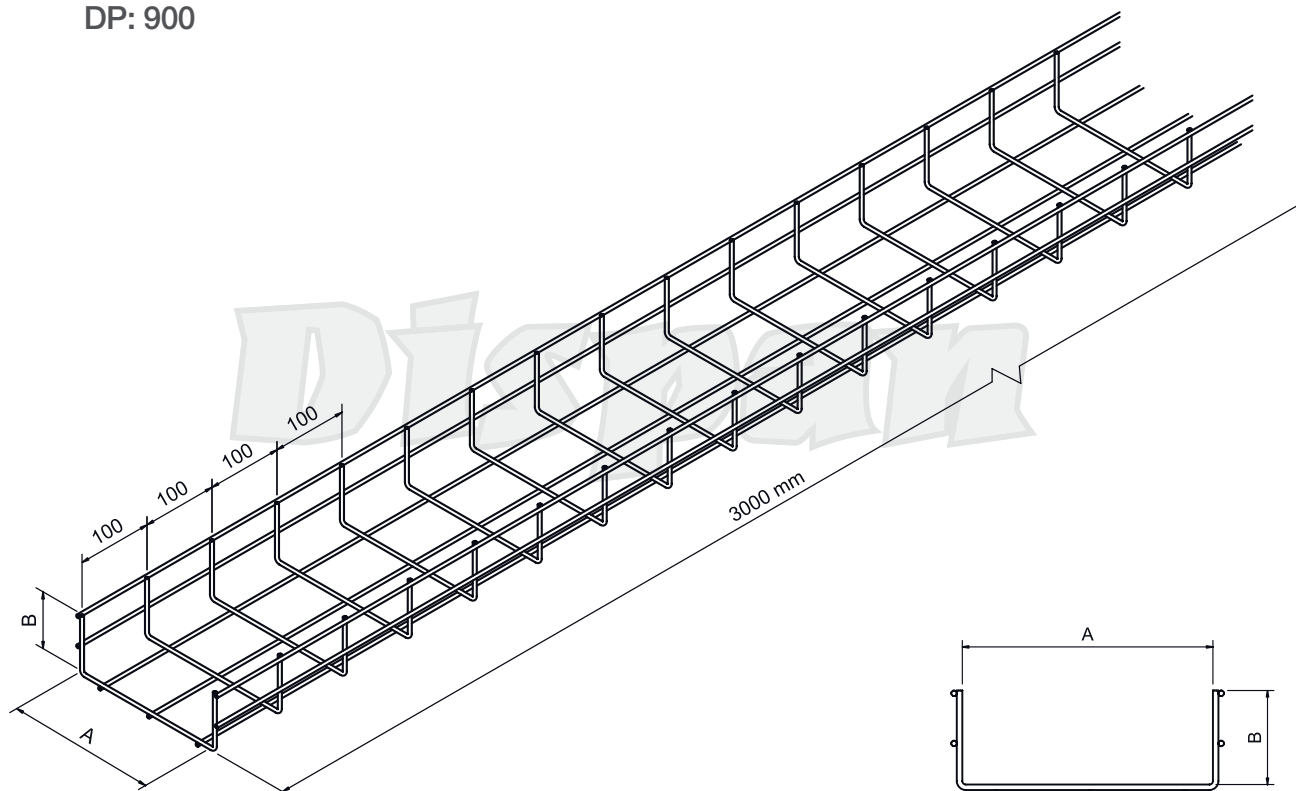

ELETROCALHA ARAMADA LEVE - REF. DP 900 / ABA 50 mm						
ESPECIFICAÇÕES		Distância entre suportes em mm / Kg. Distance between supports (mm) / loads (Kg).				
Largura mm Width	Aba mm Wight	1500 mm	2000 mm	2500 mm	3000 mm	
100	50	38 Kg	36 Kg	34 Kg	32 Kg	←
150	50	38 Kg	36 Kg	32 Kg	30 Kg	←
200	50	40 Kg	35 Kg	30 Kg	30 Kg	←
300	50	40 Kg	35 Kg	30 Kg	30 Kg	←
400	50	45 Kg	40 Kg	35 Kg	30 Kg	←
500	50	45 Kg	40 Kg	35 Kg	30 Kg	

* Carga distribuída entre suportes.

EXEMPLO:

* ou 14 cabos 0.6/1kv de 70,0 mm² no vão livre de 3.0 metros.

* ou 28 cabos 0.6/1kv de 25,0 mm² no vão livre de 3.0 metros.

* ou 25 cabos 0.6/1kv de 35,0 mm² no vão livre de 3.0 metros.

ELETROCALHA ARAMADA LEVE - REF. DP 900 / ABA 75 mm						
ESPECIFICAÇÕES		Distância entre suportes em mm / Kg. Distance between supports (mm) / loads (Kg).				
Largura mm Width	Aba mm Wight	1500 mm	2000 mm	2500 mm	3000 mm	
100	75	45 Kg	40 Kg	36 Kg	34 Kg	←
150	75	45 Kg	40 Kg	36 Kg	34 Kg	←
200	75	55 Kg	45 Kg	40 Kg	38 Kg	←
300	75	55 Kg	45 Kg	40 Kg	38 Kg	←
400	75	65 Kg	55 Kg	50 Kg	42 Kg	←
500	75	65 Kg	55 Kg	50 Kg	42 Kg	

* Carga distribuída entre suportes.

EXEMPLO:

* ou 06 cabos 0.6/1kv de 185,0 mm² no vão livre de 3.0 metros.

* ou 16 cabos 0.6/1kv de 70,0 mm² no vão livre de 3.0 metros.

* ou 14 cabos 0.6/1kv de 95,0 mm² no vão livre de 3.0 metros.

ELETROCALHA ARAMADA LEVE - REF. DP 900 / ABA 100 mm						
ESPECIFICAÇÕES		Distância entre suportes em mm / Kg. Distance between supports (mm) / loads (Kg).				
Largura mm Width	Aba mm Wight	1500 mm	2000 mm	2500 mm	3000 mm	
100	100	55 Kg	51 Kg	46 Kg	40 Kg	←
150	100	55 Kg	51 Kg	46 Kg	40 Kg	←
200	100	65 Kg	55 Kg	50 Kg	45 Kg	←
300	100	70 Kg	60 Kg	55 Kg	48 Kg	←
400	100	100 Kg	85 Kg	65 Kg	50 Kg	←
500	100	100 Kg	85 Kg	65 Kg	50 Kg	

* Carga distribuída entre suportes.

EXEMPLO:

* ou 13 cabos 0.6/1kv de 95,0 mm² no vão livre de 3.0 metros.

* ou 20 cabos 0.6/1kv de 70,0 mm² no vão livre de 3.0 metros.

* ou 30 cabos 0.6/1kv de 50,0 mm² no vão livre de 3.0 metros.

Nota.: Para outras medidas, favor solicitar.

Leito Sanitário / Eletrocalha Aramada 1/4" Tipo Leve

Wire mesh cable tray 1/4" lightweight kind

DP: 900

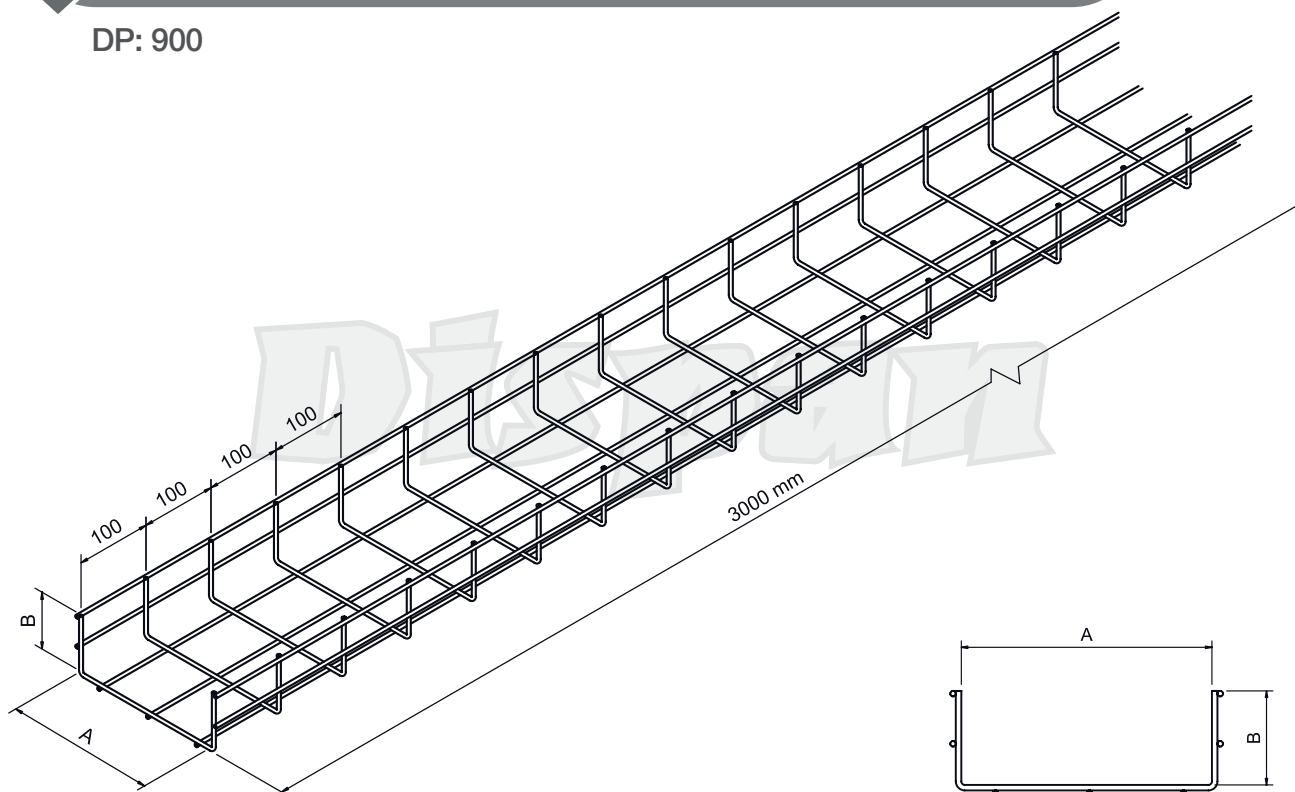

ELETROCALHA ARAMADA PESADA - REF. DP 900 / ABA 50 mm					
ESPECIFICAÇÕES		Distância entre suportes em mm / Kg. Distance between supports (mm) / loads (Kg).			
Largura mm Width	Aba mm Wight	1500 mm	2000 mm	2500 mm	3000 mm
100	50	50 Kg	47 Kg	44 Kg	40 Kg
150	50	50 Kg	47 Kg	44 Kg	40 Kg
200	50	60 Kg	50 Kg	45 Kg	40 Kg
300	50	65 Kg	55 Kg	50 Kg	40 Kg
400	50	70 Kg	60 Kg	50 Kg	40 Kg
500	50	70 Kg	60 Kg	50 Kg	40 Kg

EXEMPLO:

- ← * ou 33 cabos 0.6/1kv de 35,0 mm² no vão livre de 3.0 metros.
- ← * ou 11 cabos 0.6/1kv de 120,0 mm² no vão livre de 3.0 metros.
- ← * ou 25 cabos 0.6/1kv de 50,0 mm² no vão livre de 3.0 metros.

* Carga distribuída entre suportes.

ELETROCALHA ARAMADA PESADA - REF. DP 900 / ABA 75 mm					
ESPECIFICAÇÕES		Distância entre suportes em mm / Kg. Distance between supports (mm) / loads (Kg).			
Largura mm Width	Aba mm Wight	1500 mm	2000 mm	2500 mm	3000 mm
100	75	60 Kg	55 Kg	46 Kg	43 Kg
150	75	60 Kg	55 Kg	46 Kg	43 Kg
200	75	70 Kg	60 Kg	55 Kg	50 Kg
300	75	70 Kg	60 Kg	55 Kg	50 Kg
400	75	90 Kg	80 Kg	70 Kg	55 Kg
500	75	90 Kg	80 Kg	70 Kg	55 Kg

EXEMPLO:

- ← * ou 05 cabos 0.6/1kv de 240,0 mm² no vão livre de 3.0 metros.
- ← * ou 10 cabos 0.6/1kv de 150,0 mm² no vão livre de 3.0 metros.
- ← * ou 32 cabos 0.6/1kv de 50,0 mm² no vão livre de 3.0 metros.

* Carga distribuída entre suportes.

ELETROCALHA ARAMADA PESADA - REF. DP 900 / ABA 100 mm					
ESPECIFICAÇÕES		Distância entre suportes em mm / Kg. Distance between supports (mm) / loads (Kg).			
Largura mm Width	Aba mm Wight	1500 mm	2000 mm	2500 mm	3000 mm
100	100	65 Kg	60 Kg	50 Kg	47 Kg
150	100	65 Kg	60 Kg	50 Kg	47 Kg
200	100	85 Kg	80 Kg	75 Kg	70 Kg
300	100	95 Kg	85 Kg	80 Kg	70 Kg
400	100	140 Kg	110 Kg	85 Kg	70 Kg
500	100	140 Kg	110 Kg	85 Kg	70 Kg

EXEMPLO:

- ← * ou 13 cabos 0.6/1kv de 120,0 mm² no vão livre de 3.0 metros.
- ← * ou 09 cabos 0.6/1kv de 240,0 mm² no vão livre de 3.0 metros.
- ← * ou 12 cabos 0.6/1kv de 185,0 mm² no vão livre de 3.0 metros.

* Carga distribuída entre suportes.

Nota.: Para outras medidas, favor solicitar.

Como solicitar eletrocalha aramada

How to specify connections for wire mesh cable tray.

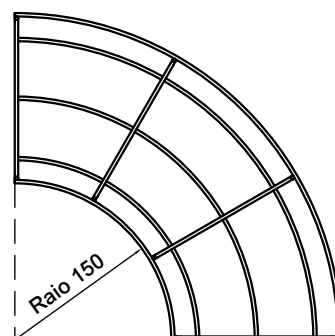
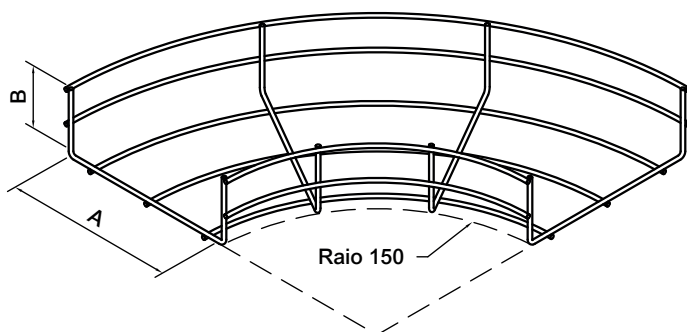

Exemplo:

Example

DP901 900 - AC - GF - 400/100 - 3/16"

Referência do catálogo de produtos com características básicas.

Modelo da eletrocalha aramada.

Matéria-prima de fabricação.

Acabamento.

Largura / altura da eletrocalha.

Bitola do arame de construção da eletrocalha aramada.

DP901 - Curva horizontal 90°

Matéria-prima base

AC - Aço carbono
AI - Aço inox

Acabamento aplicado na matéria-prima em base de aço carbono.

GF - Galvanizado à fogo por imersão
GE - Galvanizado eletrolítico
PT - Galvanizado e Pintado

Largura

400 - Largura da eletrocalha desejada (De 30mm a 1000mm)

Altura

100 - Altura da eletrocalha desejada (30mm / 50mm / 75mm / 100mm / 150mm)

Diâmetro da bitola dos arames.

3/16" - Bitola da eletrocalha aramada = Tipo Leve.
1/4" - Bitola da eletrocalha aramada = Tipo Pesado.

Descritivo técnico.

DP901 - Curva horizontal 90° para eletrocalha aramada DP 900, em aço carbono, galvanizado fogo, largura de 400 mm, com aba de 100 mm na bitola 3/16", raio de 300 mm, curvilínea.

Nota - 1

Ocasionalmente podem ocorrer algumas distorções de medidas em nossas peças, por diversos fatores. Por este motivo damos uma tolerância de 5,0 mm entre as medidas mencionadas no catálogo e as peças reais. As peças de conexões entre as partes contêm furos oblongos para corrigir eventuais diferenças.

Curva Horizontal 90°

DP: 901

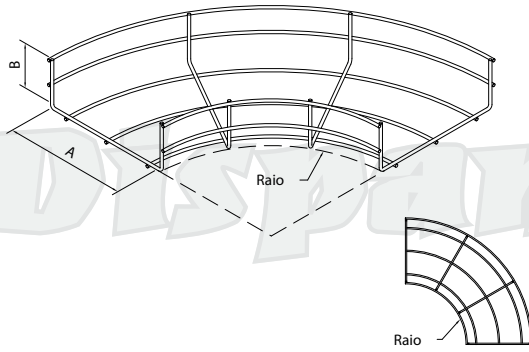

Curva Horizontal 45°

DP: 902

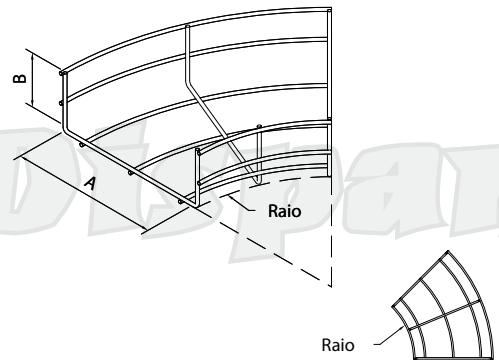

Curva Vertical Externa 90°

DP: 903

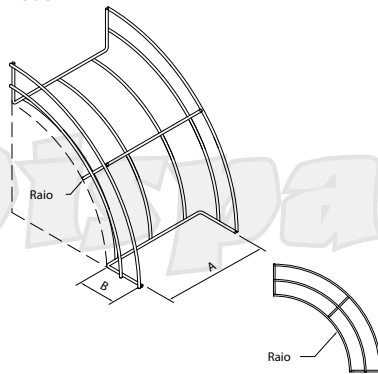

Curva Vertical Externa 45°

DP: 904

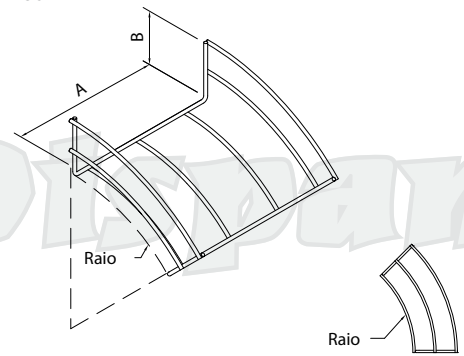

Curva Vertical Interna 90°

DP: 905

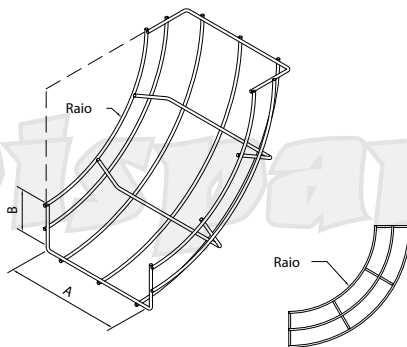

Curva Vertical Interna 45°

DP: 906

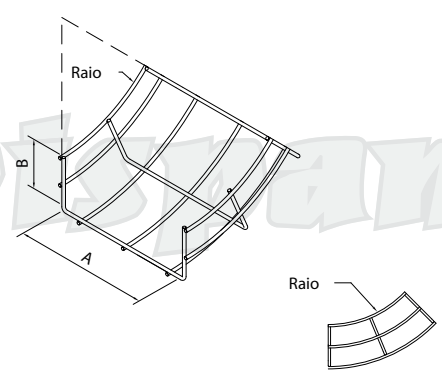

Tê Horizontal 90°

DP: 907

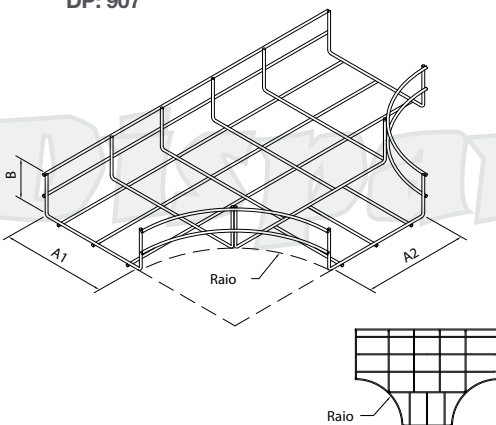

Cruzeta Horizontal 90°

DP: 908

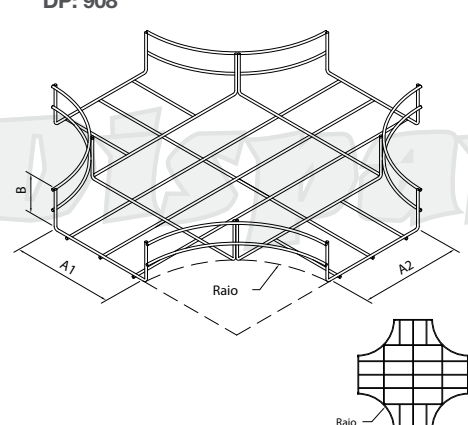

Redução Concêntrica

DP: 909

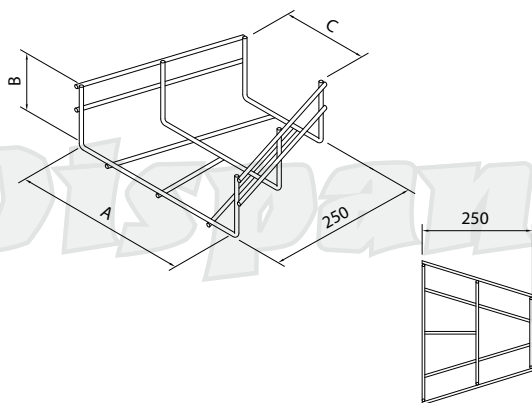

Redução Esquerda

DP: 910

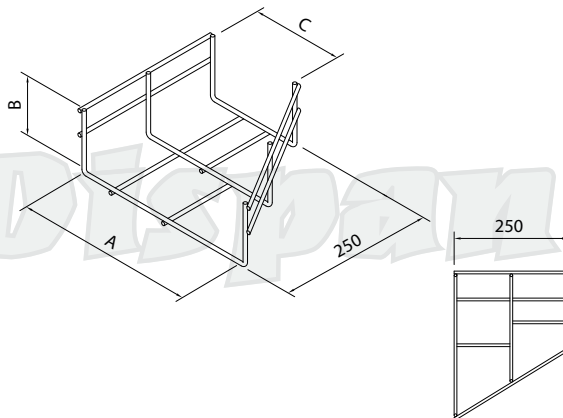

Redução Direita

DP: 911

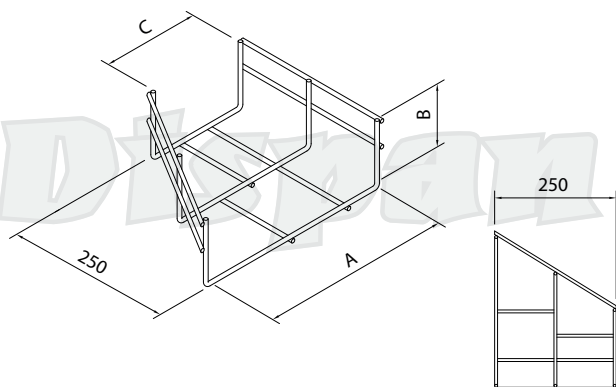

Conector Curto

DP: 912

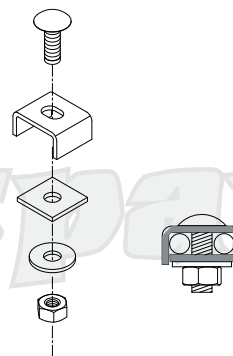

Obs.: Incluso parafuso, porca e arruela.

Conector Curto Reforçado

DP: 913

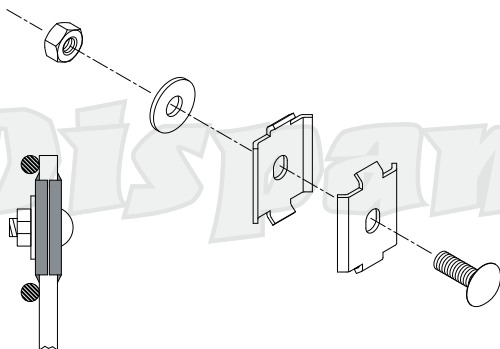

Obs.: Incluso parafuso, porca e arruela.

Conector Longo

DP: 914

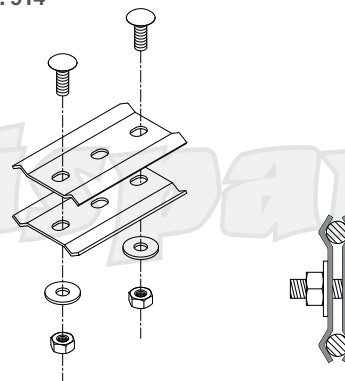

Obs.: Incluso parafuso, porca e arruela.

Junção Articulada P/ Eletrocalha Aramada

DP: 915

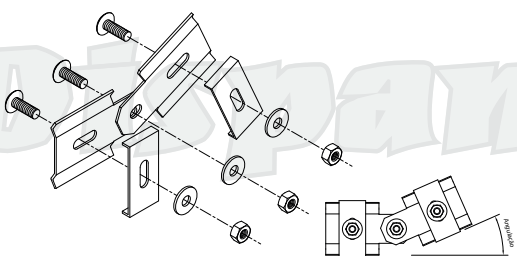

Obs.: Incluso parafuso, porca e arruela.

União Curta

DP: 916

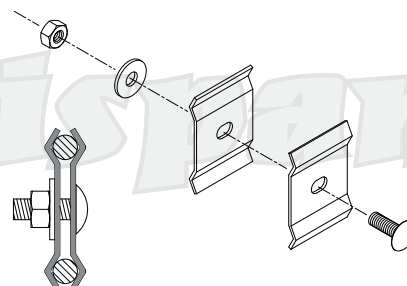

Obs.: Incluso parafuso, porca e arruela.

Presilha Para Base

DP: 917

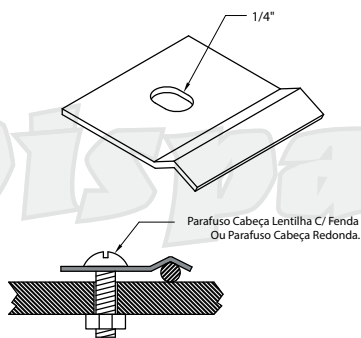

Obs.: Não inclui parafuso.

Conector Longo de Pressão

DP: 918

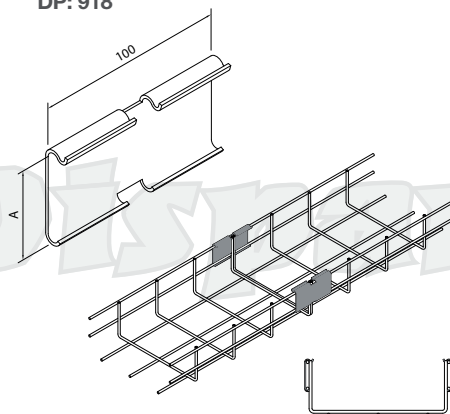

Conector Trecho Reto Reforçado

DP: 919

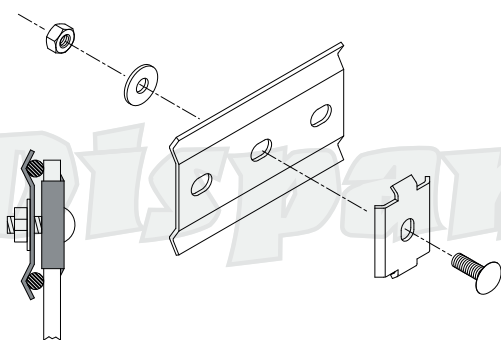

Obs.: Incluso parafuso, porca e arruela.

Presilha Para Tapa de Encaixe Para Aramado

DP: 920

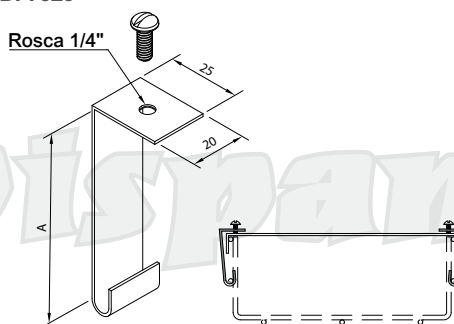

Obs.: Incluso parafuso, porca e arruela.

Flange P/ Ligação em Painel

DP: 921

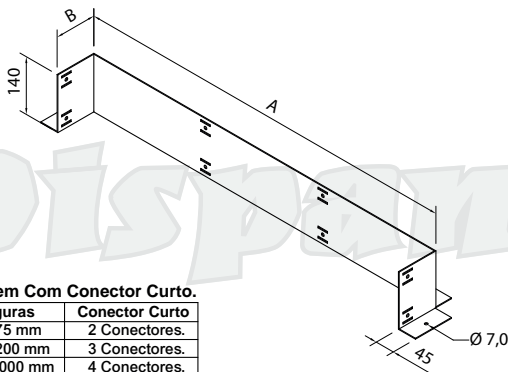

Montagem Com Conector Curto.

Larguras	Conector Curto
50 à 75 mm	2 Conectores.
100 à 200 mm	3 Conectores.
300 à 1000 mm	4 Conectores.

Curva de Inversão 90°

DP: 922

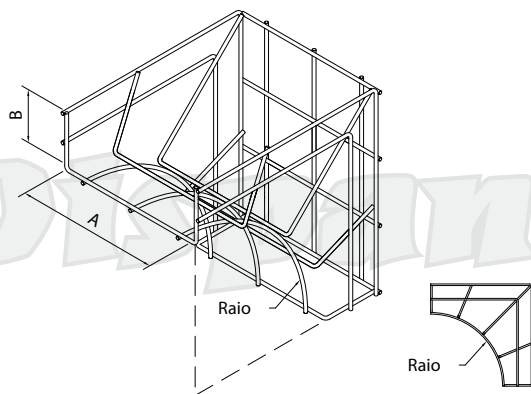

Curva Com Passagem Reto de Subida 90°

DP: 923

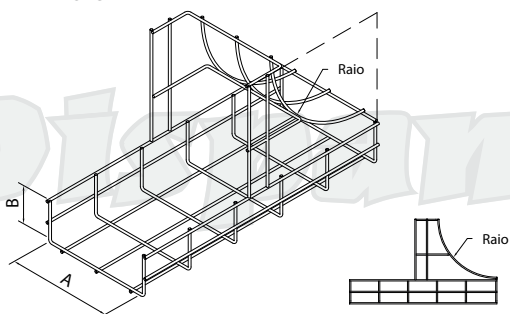

Cotovelo Reto 90°

DP: 924

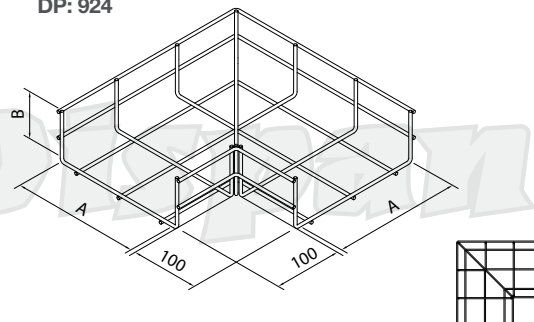

Tê Reto 90°

DP: 925

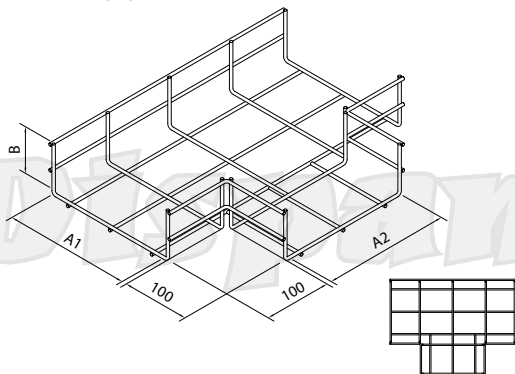

Cruzeta Reto 90°

DP: 926

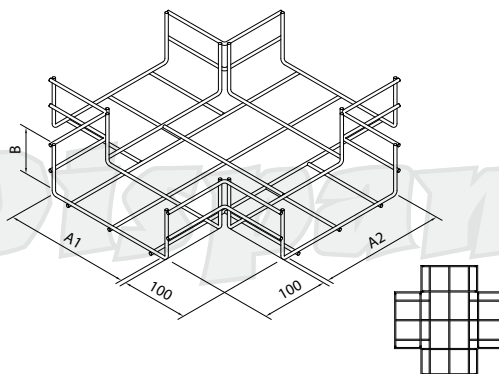

Tê Vertical de Descida 90°

DP: 927

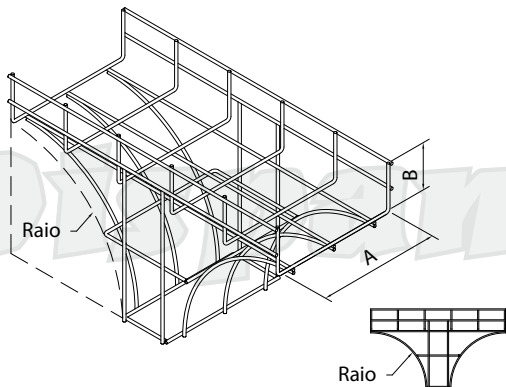

Tê Vertical de Subida 90°

DP: 928

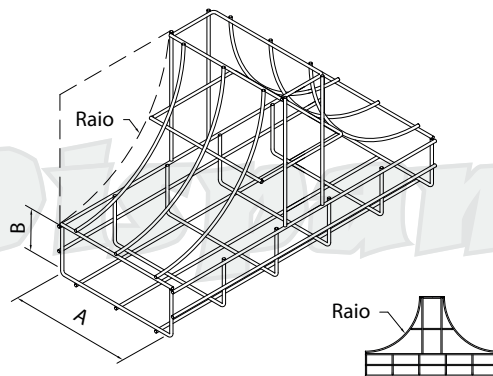

Tê Vertical de Descida Lateral

DP: 929

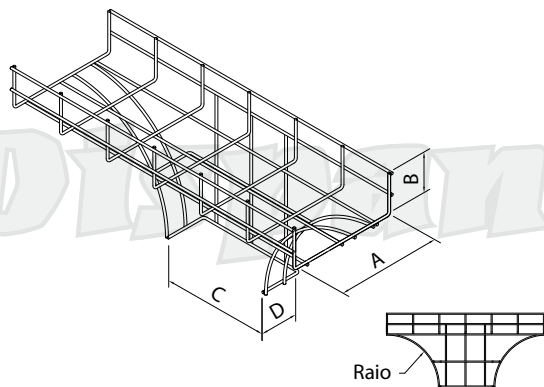

Tampa de Encaixe P/ Aramado

DP: 930

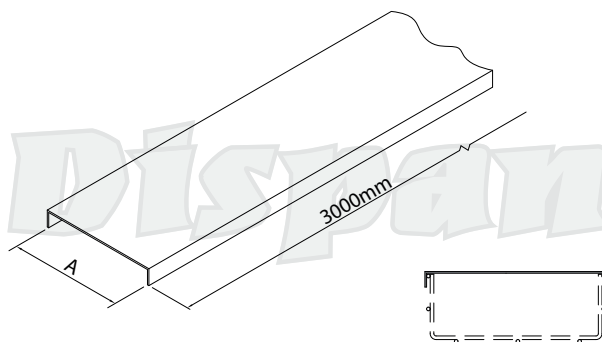

Obs.: Informar a bitola do arame.

Tampa de Pressão P/ Eletrocalha Aramada

DP: 931

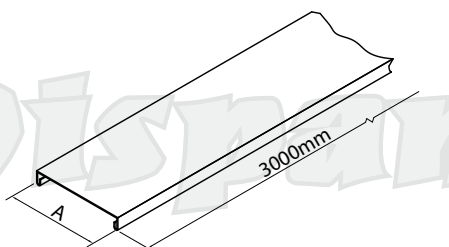

Nota 1: Fabricamos Tampas de Pressão, Somente Para os Trechos Retos.
Nota 2: Tampas de Pressão, Somente Para Eletrocalha Aramada Com Altura Superior à 50 mm.

Septo Divisor Liso

DP: 932

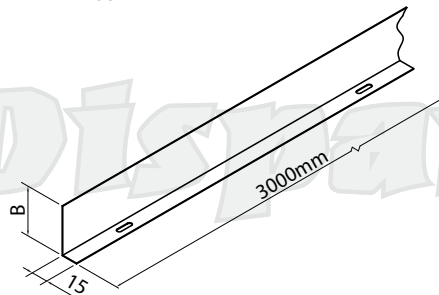

Septo Divisor Perfurado

DP: 933

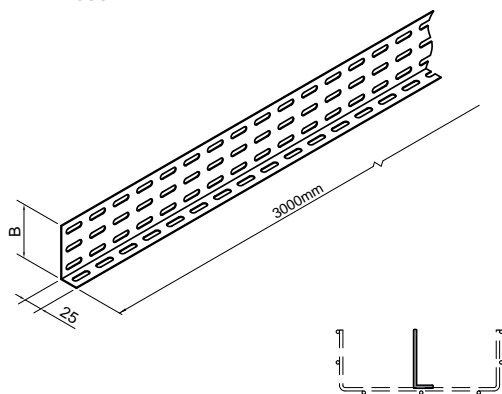

Suporte P/ Caixa de Tomada em Eletrocalha Aramada

DP: 934

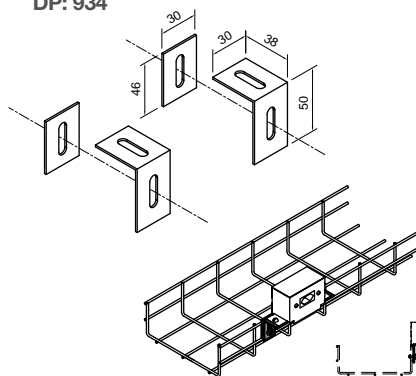

Suporte Horizontal Para Eletrocalha Aramada

DP: 935

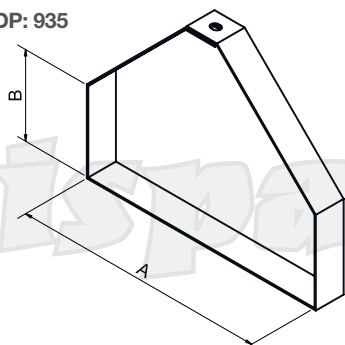

Obs.: De acordo com as dimensões das eletrocalhas.

Suporte Vertical P/ Eletrocalha Aramada

DP: 936

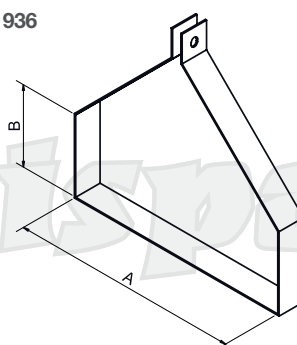

Obs.: De acordo com as dimensões das eletrocalhas.

Suporte Duplo P/ Eletrocalha Aramada

DP: 937

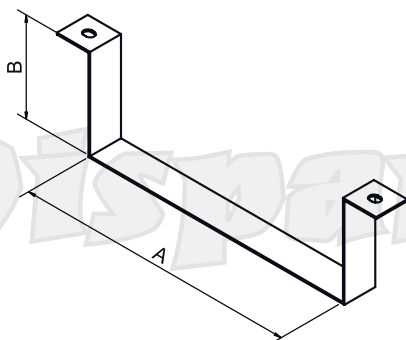

De acordo com as dimensões das eletrocalhas.

Suporte Reforçado P/ Eletrocalha Aramada

DP: 938

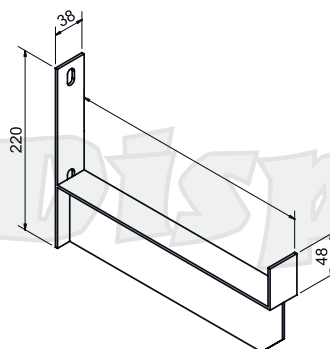

Referência: DP 938	
Suporte reforçado.	
Tabela de cargas.	
A mm	Carga Máxima Kg.
50	120
100	80
150	70
200	50
300	20
400	15

Largura máxima de "A" = 400mm.

Tala Para Saída Horizontal em Eletrocalha Aramada

DP: 939

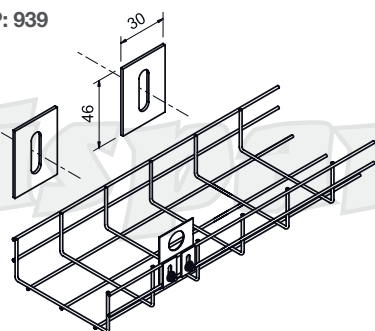

Saída Horizontal P/ Eletroduto

DP: 751

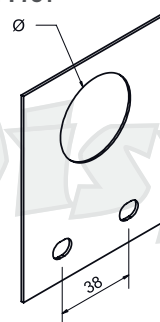

Referência	Ø
751 - 1	1/2"
751 - 2	3/4"
751 - 3	1"
751 - 4	1.1/4"
751 - 5	1.1/2"
751 - 6	2"
751 - 7	3"
751 - 8	3.1/2"
751 - 9	4"

Obs.: Indicar o Ø.

Exemplo de montagem para eletrocalha aramada

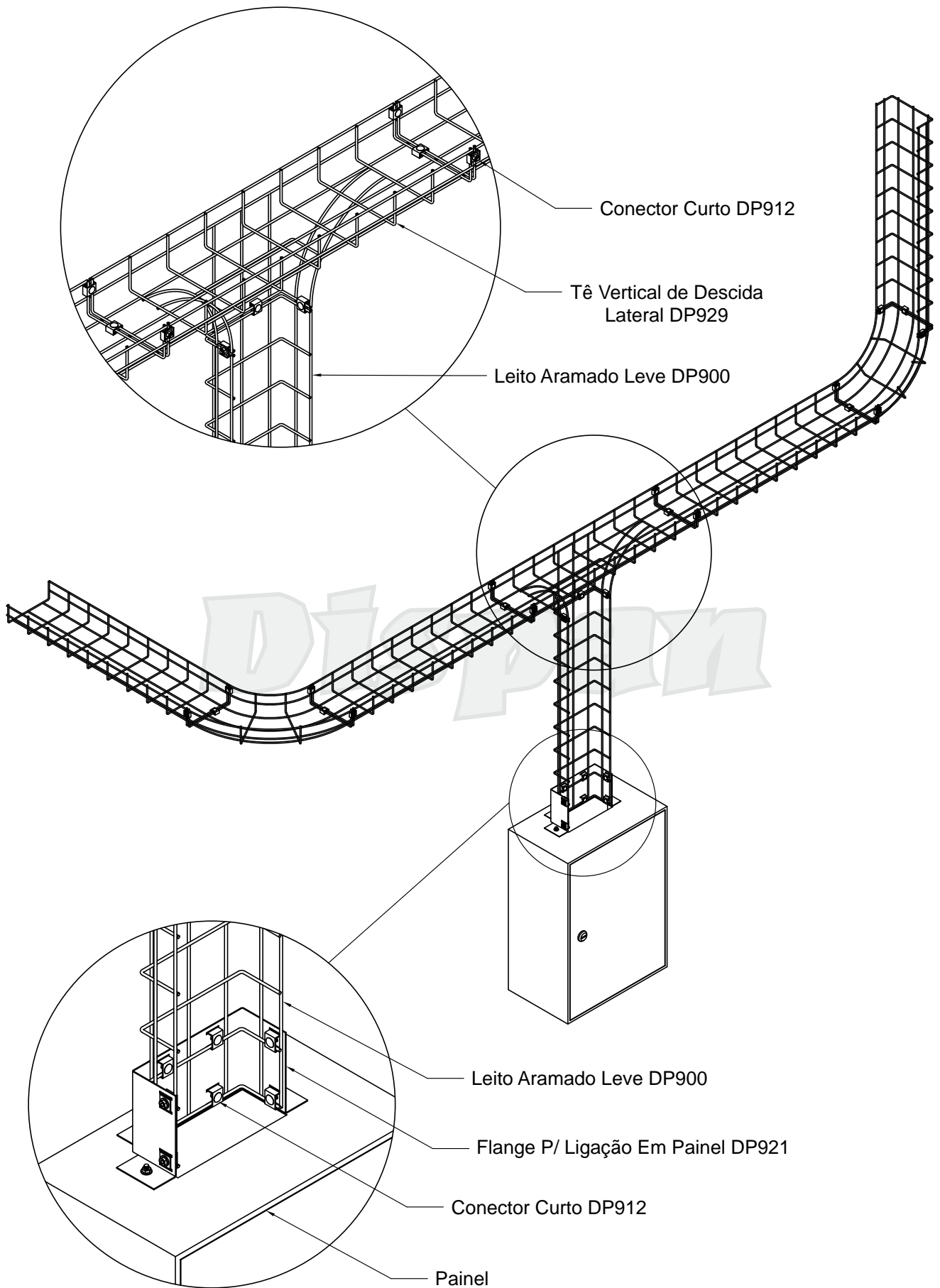

Exemplo de montagem para eletrocalha aramada

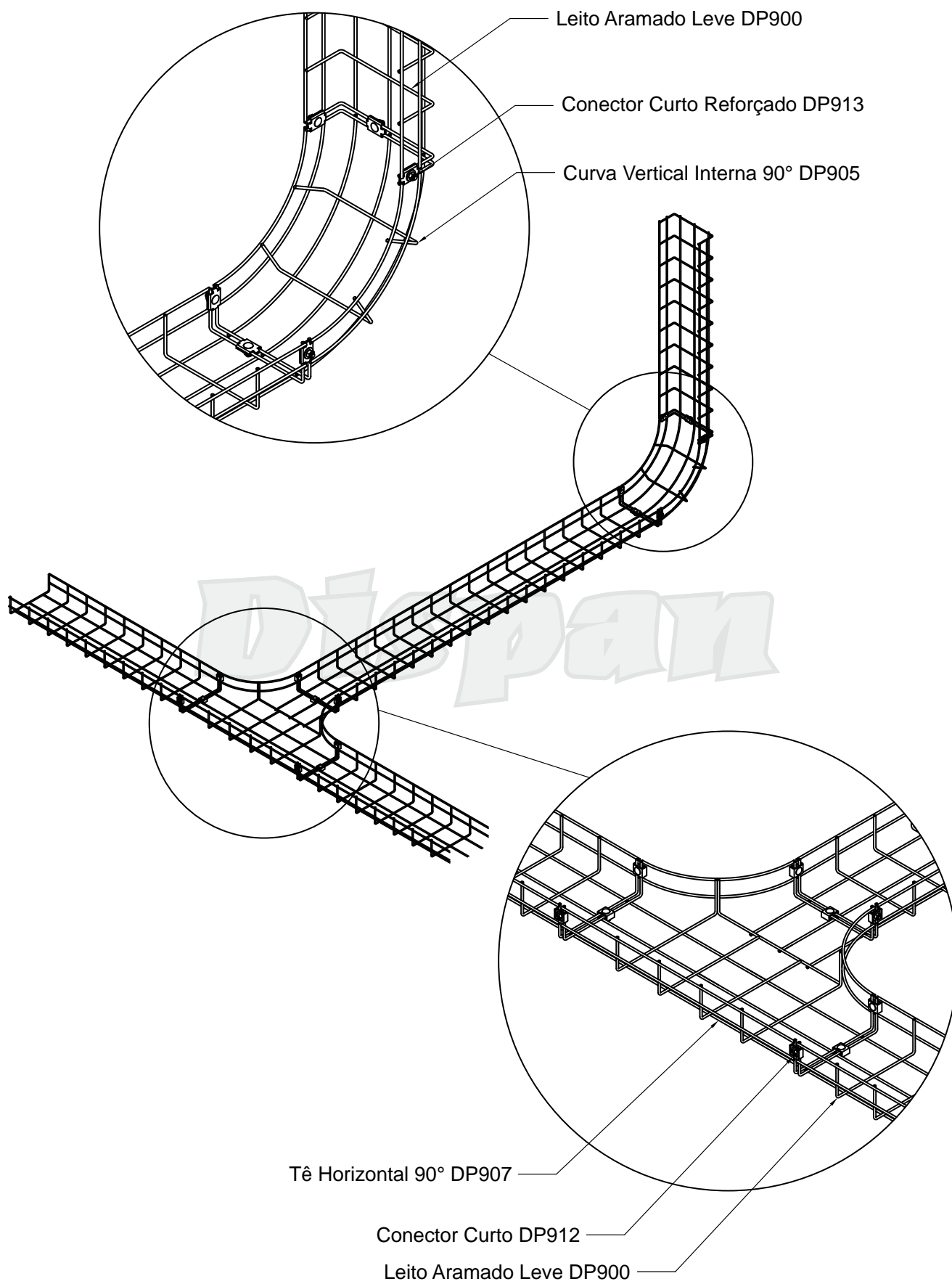

Exemplo de montagem para eletrocalha aramada

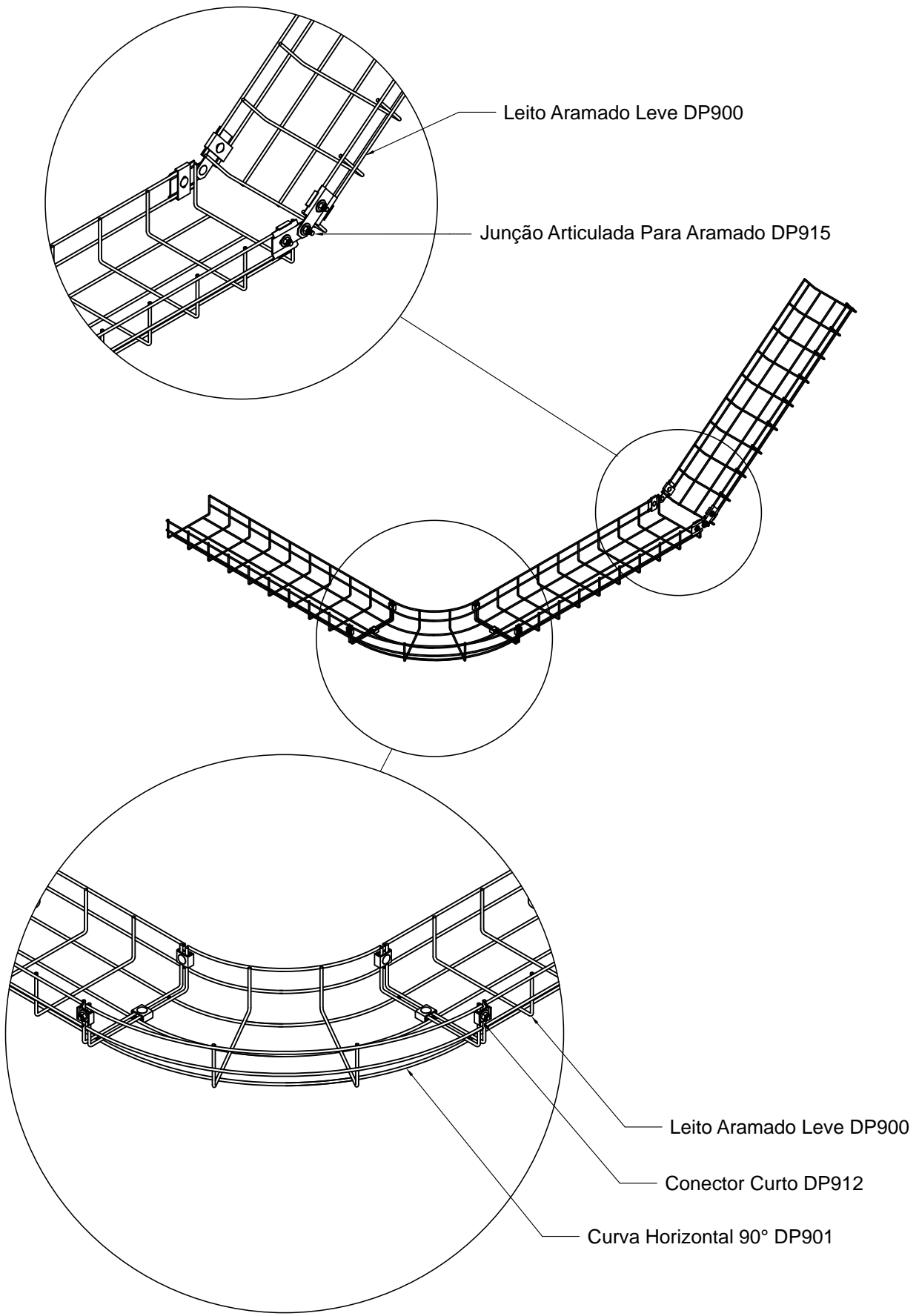

Exemplo de montagem para eletrocalha aramada

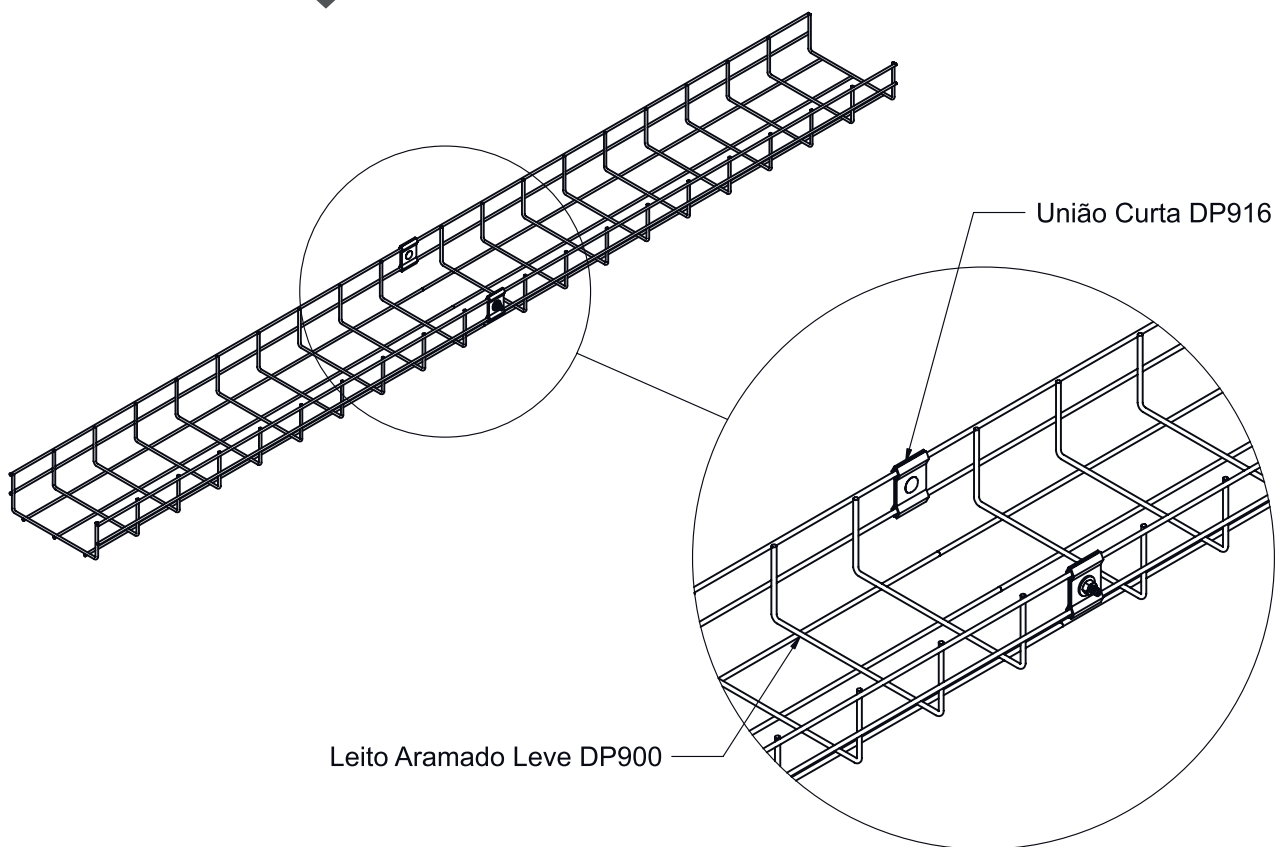

Dispan

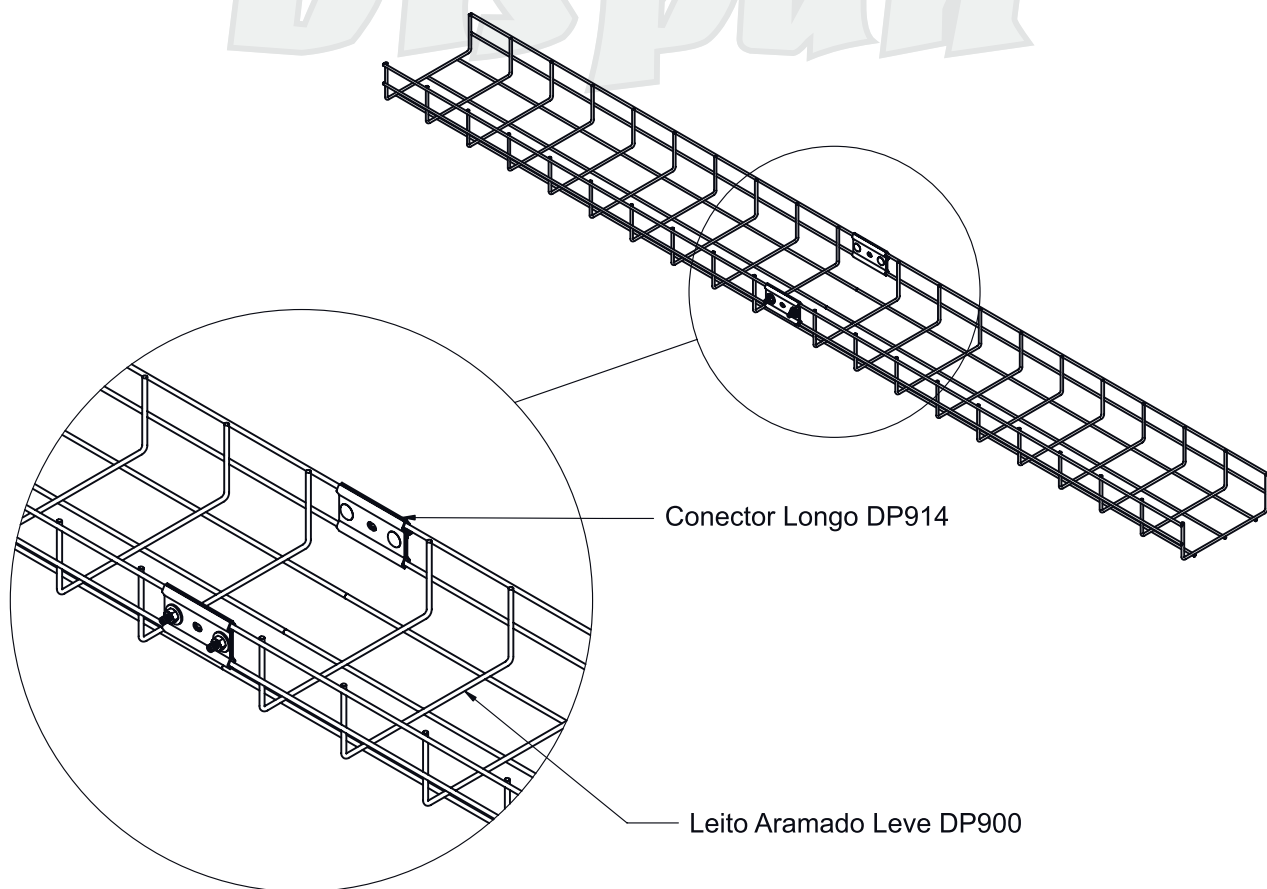



Dispan

Rua José Francisco da Silva, 133/144 • Fritz Berzin
Nova Odessa / SP • Brasil • CEP 13380-248
+55 (19) 3466.9300 • comercial@dispan.com.br

www.dispan.com.br
